

DISASSEMBLY AND ASSEMBLY (Continued)

1. Clamp link shaft in vise with halfshaft supported on work bench. Using CV Joint Puller T86P-3514-A1 and Impact Slide Hammer D79P-100-A or equivalent, separate link shaft from halfshaft.

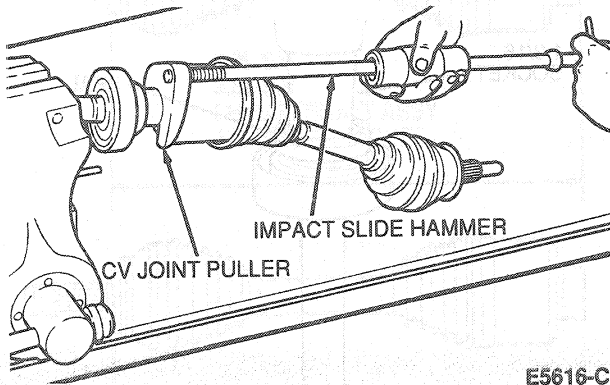

E5616-C

2. Remove seal from link shaft by prying it off with a screwdriver.

CAUTION: Use care to prevent damage to bearing dust shield.

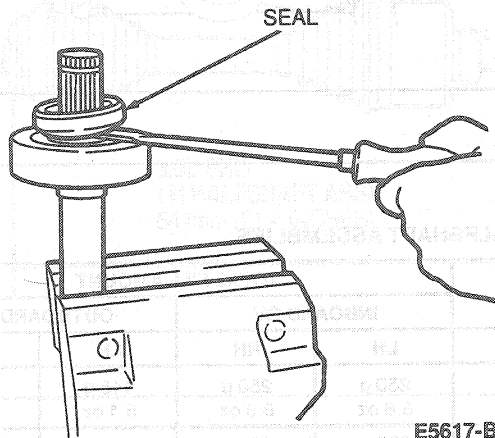

E5617-B

3. Place shaft assembly in arbor press, using Bearing Puller Attachment D84L-1123-A or equivalent, with bearing supported and press out link shaft.

(Continued)

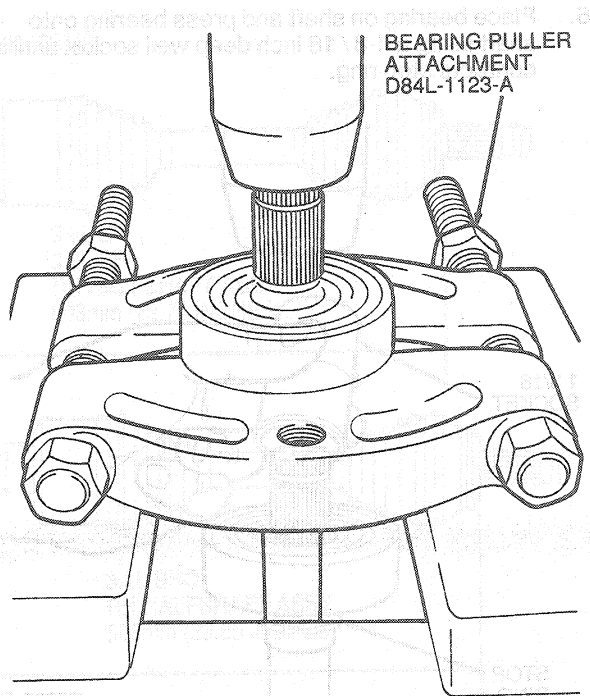

E5618-C

4. Support link shaft in press fixture with step in shaft.

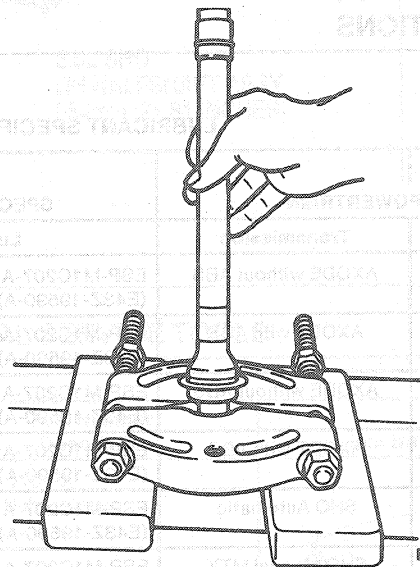

E5619-A