

DISASSEMBLY AND ASSEMBLY (Continued)

3. When replacing damaged CV joint boots, the grease should be checked for contamination. If the CV joints are operating satisfactorily, and the grease does not appear to be contaminated, add grease and replace the boot.

If the grease appears contaminated, proceed with a complete CV joint disassembly and inspection.

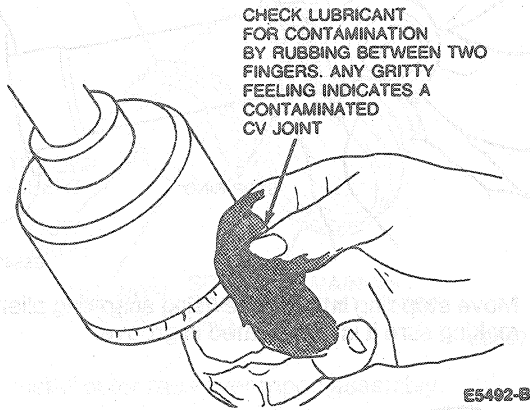

4. Move stop ring back on shaft using snap-ring pliers.

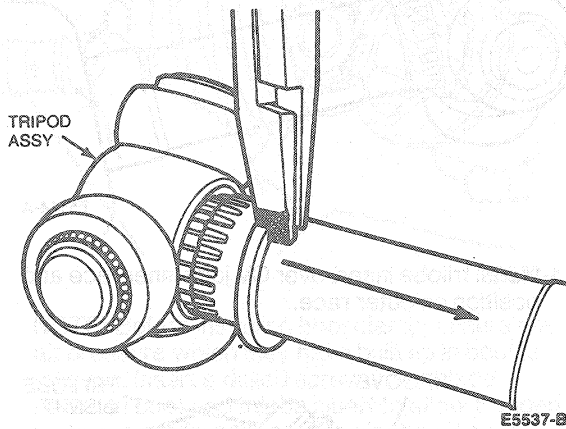

5. Move tripod assembly back on shaft to allow access to circlip.

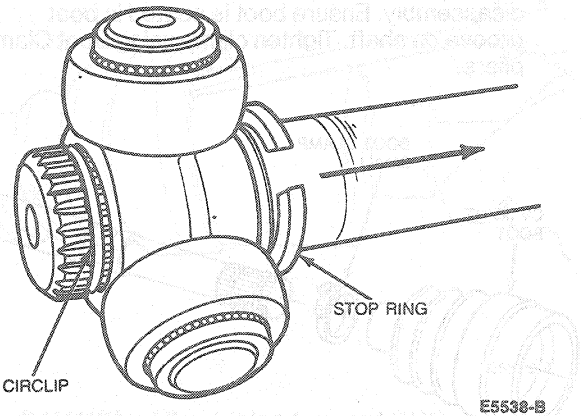

CAUTION: Circlips must not be reused. Replace with new circlips before reassembly

6. Remove circlip from shaft.

CAUTION: CIRCLIPS MUST NOT BE REUSED. REPLACE WITH NEW CIRCLIPS BEFORE REASSEMBLY.

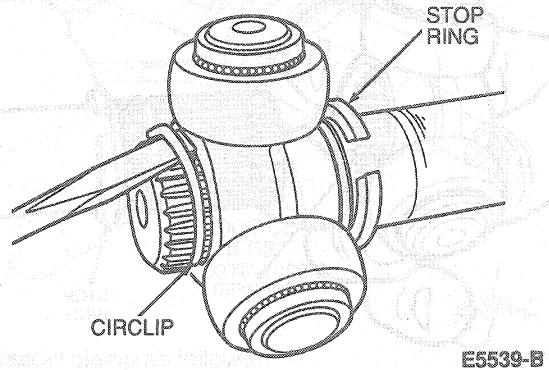

7. Remove tripod assembly from shaft. Remove boot if necessary.

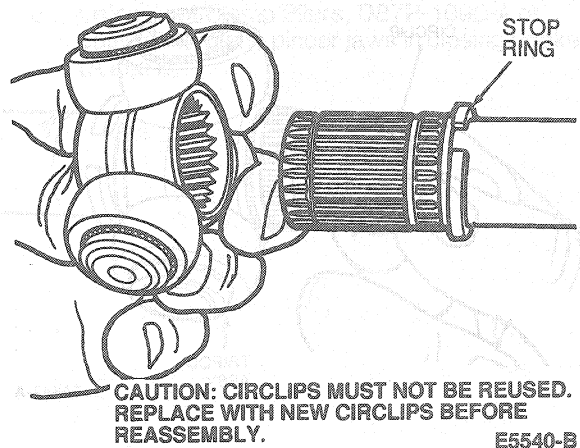

Assembly

CAUTION: Tighten clamp securely, but not to the point where clamp bridge is cut or boot is damaged.