

DISASSEMBLY AND ASSEMBLY (Continued)

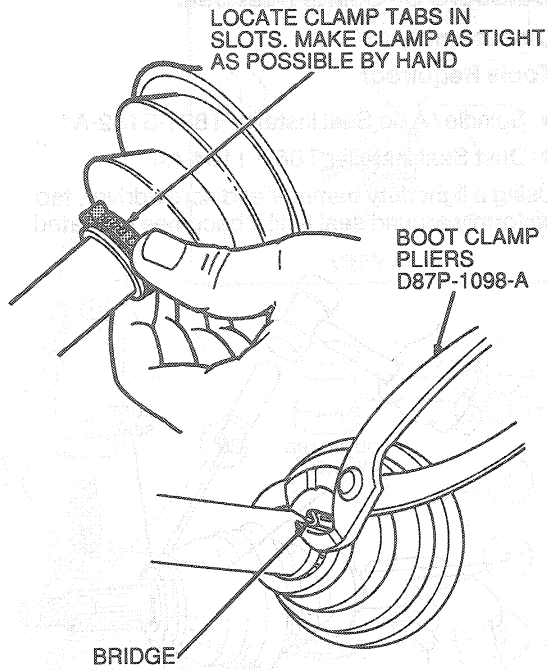

E4298-F

7. If removed, install the stop ring.
If not removed, ensure stop ring is properly seated in its groove.

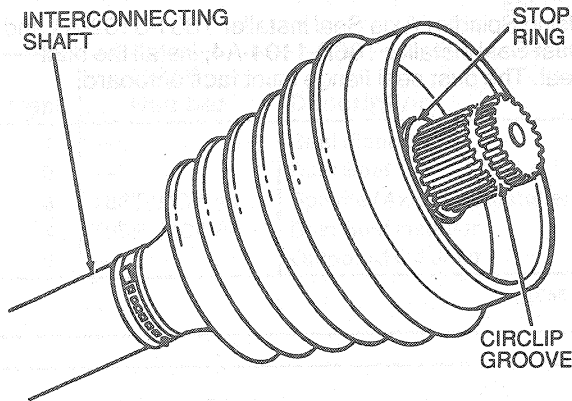

E4296-C

NOTE: To install circlip, start one end in the groove and work the circlip over the stub shaft end and into the groove. This will avoid over-expanding the circlip.

CAUTION: DO NOT reuse circlip. Replace circlips before assembly.

8. Install a new circlip, supplied with the service kit, in the groove nearest the end of the shaft.
Do not over-expand or twist the circlip during installation.

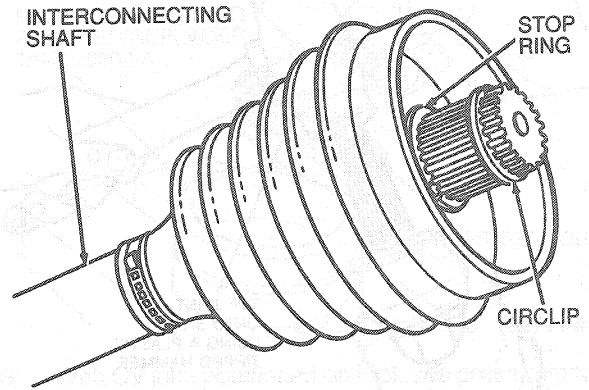

E4293-C

9. Before positioning boot over CV joint, pack CV joint and boot with the grease supplied in the service kit as follows:
NOTE: Use Ford Constant Velocity Joint Grease E43Z-19590-A (ESP-M1C207-A) or equivalent on all outboard CV joints.
Pack CV joint with grease. Any grease remaining in tube is to be spread evenly inside boot. For grease quantity, refer to Lubricant Specifications.

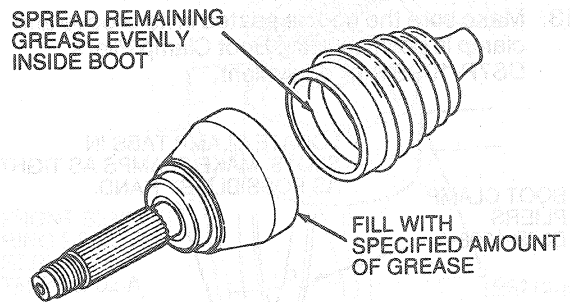

E6700-B