

REMOVAL AND INSTALLATION (Continued)

TO DISCONNECT COUPLING

CAUTION — RELIEVE FUEL PRESSURE BEFORE DISCONNECTING COUPLING

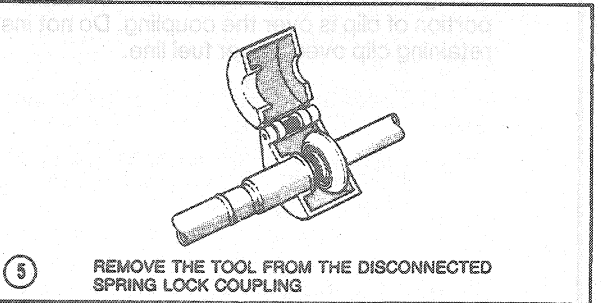
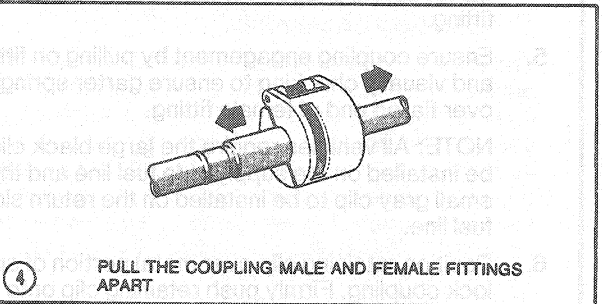
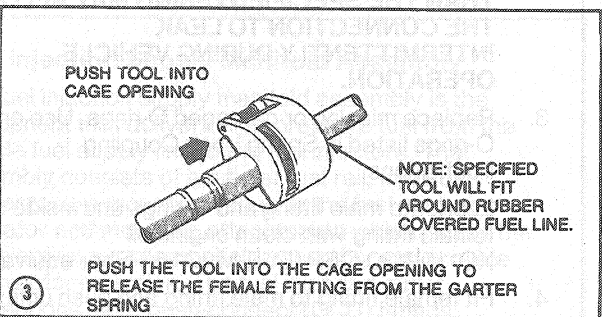
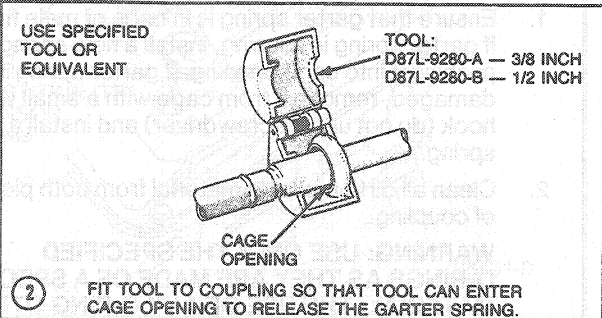
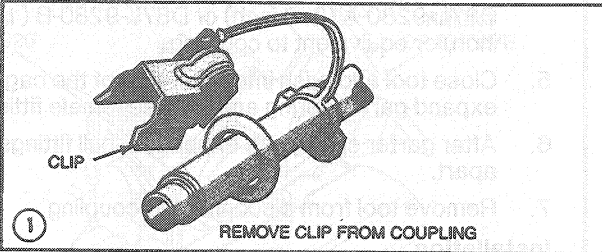

TO CONNECT COUPLING

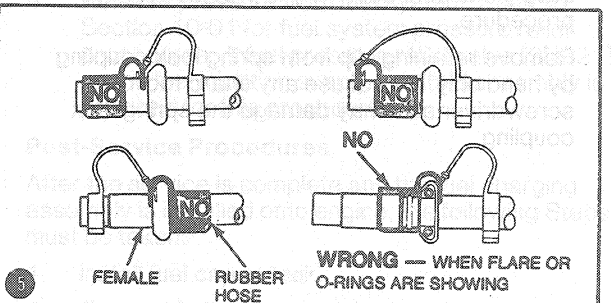
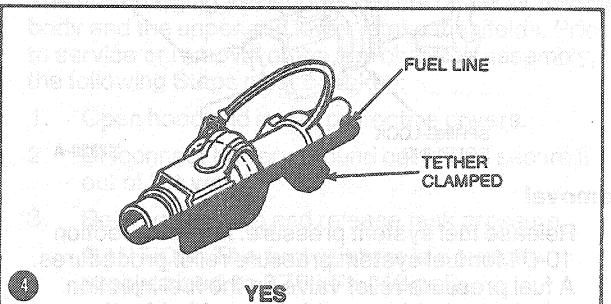
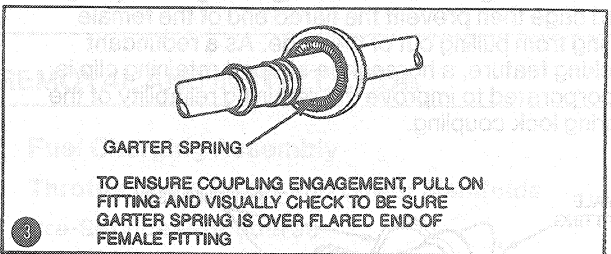
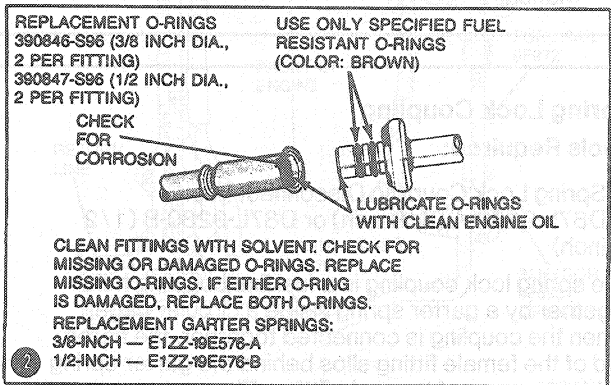
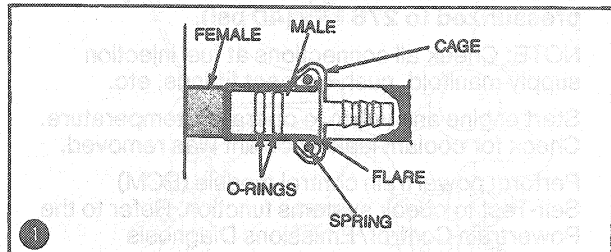

V7392-A