

REMOVAL AND INSTALLATION (Continued)

4. Aligning bolt holes, lower assembly enough to install PCV hose to tube beneath throttle body. Align EGR tube nut to EGR valve and lower assembly onto intake manifold. Start EGR tube nut engagement to EGR valve. Install four center retaining bolts and hand tighten. Remove guide pins. Install stud bolt and remaining retaining bolt. Tighten retaining bolts to 20-30 N·m (15-22 lb-ft) in sequence as illustrated.
5. Install generator brace to throttle body and generator bracket. Tighten nuts to 12-20 N·m (9-15 lb-ft).
6. Tighten EGR tube nut to 35-65 N·m (26-48 lb-ft).
7. Connect DPFE sensor hoses to EGR tube nipples. Check for cracked or deformed condition and replace as necessary.
8. Connect premarked vacuum lines to their original locations. Check for cracked or deformed condition and replace as necessary.
9. Connect electrical connections to TP, DPFE, CSI and IAC sensors.
10. Install vapor purge hose to fitting near TP sensor.
11. Install throttle cable bracket to side of throttle body. Tighten retaining bolts to 17 N·m (13 lb-ft).
12. Connect throttle cable and TV cable to throttle body lever.
13. Connect fuel supply tubes to CSI assembly.
14. Install clean air flex tube to throttle body. Tighten retaining clamp to 2.7-4.5 N·m (24-48 lb-in). Connect PCV closure and aspirator hose to their original locations.
15. Connect negative battery terminal.
16. Start engine and check for vacuum, exhaust and fuel leaks.
17. Check engine idle. Adjust as necessary. Refer to the Powertrain Control/Emissions Diagnosis manual.³
18. Install snowshield onto IAC valve. Tighten retaining screw to 8-12 N·m (6-8 lb-ft).

Cold Start Injector (CSI)

Removal and Installation

1. Remove flexible fuel throttle body as outlined.
2. Remove two bolts retaining CSI spray bar assembly (9F880) to throttle body.
3. Remove CSI and gasket from throttle body.
4. Using a 1/4 inch allen wrench, remove plug located on throttle body opposite CSI mounting surface.

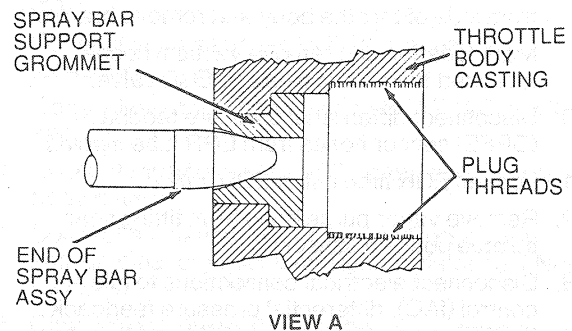
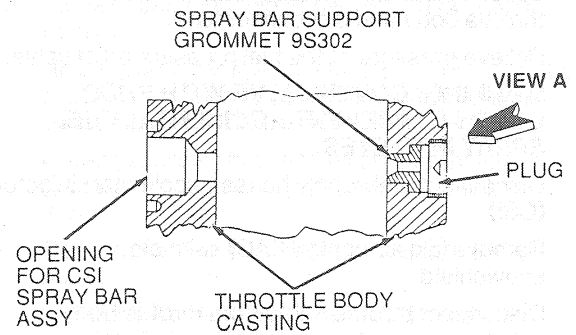

V8651-A

CAUTION: Use care when installing spray bar to throttle body. DO NOT FORCE or damage to CSI and spray bar assembly will occur.

5. Install CSI and spray bar assembly with new gasket (9P849) to throttle body, with end of spray bar assembly (9F880) resting in support grommet located behind plug in throttle body casting.
6. Align CSI to throttle body and install retainer bolts. Tighten bolts to 8-11 N·m (70-97 lb-in).
7. Verify that end of spray bar is resting in support grommet. If not, repeat Steps 1 through 6.
8. Apply Pipe Sealant with Teflon® D8AZ-19544-A (ESG-M4G 194-A) or equivalent in a clockwise direction to plug and install plug in throttle body. Tighten plug to 10-15 N·m (7-11 lb-ft).
9. Reinstall throttle body as outlined. Inspect for leaks with engine running.

Idle Air Control (IAC) Valve Assembly

Removal

1. Disconnect idle air control (IAC) valve assembly connector from wiring harness.

³ Can be purchased as a separate item.