

## REMOVAL AND INSTALLATION (Continued)

3. Loosen clean air flex tube retaining clamp at throttle body and disconnect tube.
4. Relieve pressure at the fuel pressure relief valve.  
**WARNING: COVER VALVE WITH SHOP CLOTH TO PREVENT ACCIDENTAL FUEL SPRAY INTO EYES.**
5. Disconnect fuel supply hoses to cold start injector (CSI).
6. Remove idle air control (IAC) solenoid snowshield.
7. Disconnect throttle cable from throttle body.
8. Remove two throttle cable bracket retaining bolts from side of throttle body and remove bracket.
9. Mark location and remove vacuum hoses attached to vacuum tree and EGR valve.
10. Disconnect differential pressure feedback (DPFE) sensor hoses from EGR tube nipples.
11. Loosen EGR tube nut at EGR valve.
12. Remove vapor purge hose from fitting near throttle position sensor.
13. Disconnect electrical connections to idle air control (IAC), differential pressure feedback (DPFE), cold start injector (CSI) and throttle position sensors.
14. Remove generator brace retaining nuts from generator bracket and throttle body stud. Remove brace.
15. Loosen and remove five throttle body retaining bolts and stud bolt noting their locations.
16. Lift throttle body straight up and remove PCV hose from tube beneath assembly. Maneuver throttle body away from EGR tube and remove assembly. Discard old intake manifold upper gasket.
17. Cover intake manifold ports to prevent foreign material from entering manifold.

**NOTE:** The throttle body is to be replaced as an assembly only for the FF vehicle. Reuse original vacuum tree, EGR valve and DPFE assembly with new throttle body.

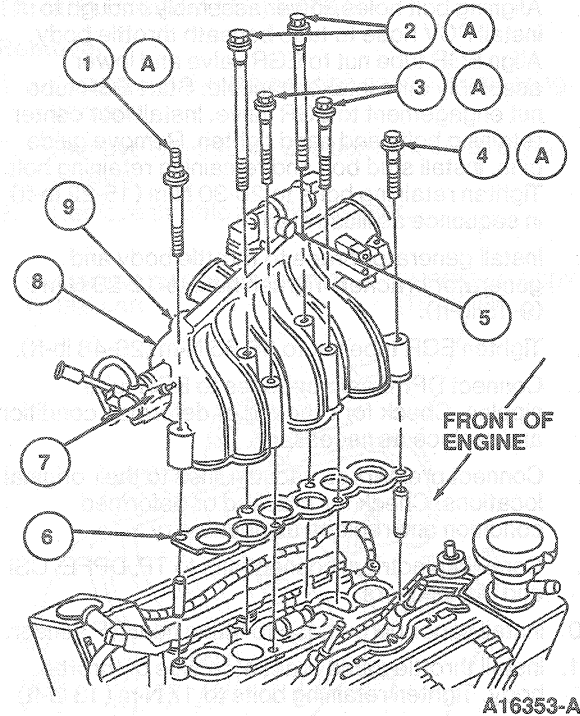

A16353-A

Item	Part Number	Description
1A	—	Stud Bolt
2A	—	Bolt M8 X 1.25 X 130 (2 Req'd)
3A	—	Bolt M8 X 1.25 X 100 (2 Req'd)
4A	—	Bolt
5	—	Purge Port
6	9E926	Throttle Body
7	—	Cold Start Injector
8	9E926	Throttle Body
9	9A474	Intake Manifold Vacuum Outlet Fitting and Cap
A	—	Tighten to 25 N-m (19 Lb-Ft)

**Installation**

**NOTE:** Lightly oil all bolt and stud threads prior to installation.

1. Clean and inspect sealing surfaces of intake manifold and throttle body.  
**CAUTION: Use care when cleaning gasket surfaces as aluminum gouges easily which forms leak paths.**
2. Install guide pins if available in front and rear bolt holes.
3. Place new intake manifold upper gasket over guide pins.