

**IN-VEHICLE SERVICE (Continued)**

9. Start engine and check for coolant leaks.

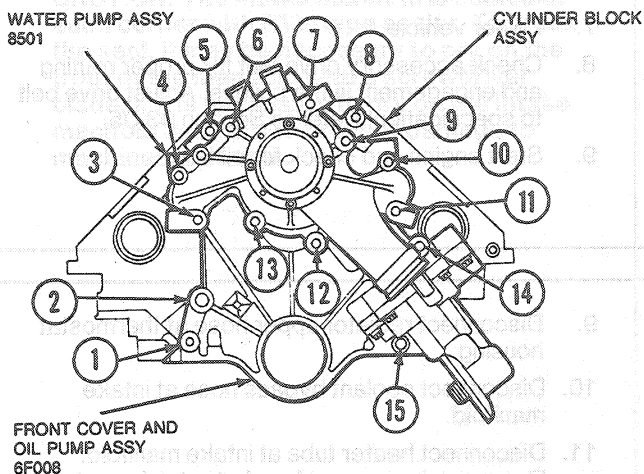

FASTENER AND HOLE NO.	HOLE NO.		FASTENERS	
	WATER PUMP	FRONT COVER	PART NO.	PART NAME
1.		4	N805112	STUD
2.		2	N805112	STUD
3.	2	9	N804757	STUD
4.	1	8	N804757	STUD
5.		10	N605787	BOLT
6.	9	15	N605908	BOLT
7.	8	16	N605908	BOLT
8.		11	N605787	BOLT
9.	7	17	N804756	BOLT
10.	6	1	N805275	STUD
11.	5	7	N804757	STUD
12.	4	13	N605908	BOLT
13.	3	14	N605908	BOLT
14.		6	N804839	BOLT
15.		5	N804841	CAP SCREW
3, 4, 10, 11	2, 1, 6, 5	9, 8, 1, 7	N804758	NUT

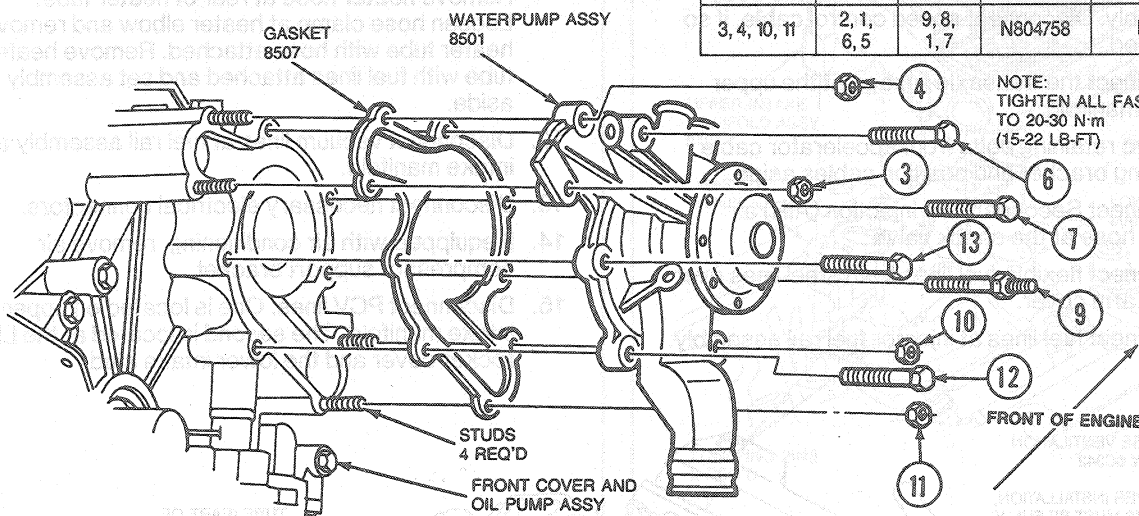

NOTE:  
TIGHTEN ALL FASTENERS  
TO 20-30 N·m  
(15-22 LB-FT)

A11388-C

**Crankshaft Front Oil Seal**

**Tools Required:**

- Crankshaft Damper Remover T58P-6316-D
- Front Cover Seal Installer T70P-6B070-A
- Damper / Front Cover Seal Installer T82L-6316-A
- Vibration Damper Remover Adapter T82L-6316-B

**Removal**

1. Loosen accessory drive belt idler.
2. Raise vehicle on hoist. Refer to Section 00-02.
3. Disengage accessory drive belt and remove crankshaft pulley.

4. Remove crankshaft damper using Crankshaft Damper Remover T58P-6316-D and Vibration Damper Remover Adapter T82L-6316-B.

**CAUTION:** Use care to prevent damage to front cover and crankshaft.

5. Remove seal from the front cover using a screwdriver.

**Installation**

1. Inspect front cover and crankshaft damper for damage, nicks, burrs or other roughness which may cause the seal to fail. Service or replace components as necessary.
2. Lubricate the seal lip with clean engine oil and install the seal using Damper / Front Cover Seal Installer T82L-6316-A and Front Cover Seal Installer T70P-6B070-A.