

IN-VEHICLE SERVICE (Continued)

Front Cover

Removal

1. Disconnect battery ground cable.
2. Drain cooling system.
3. Loosen four water pump pulley bolts while 6K belt is in place.
4. Using a 1/2-inch drive breaker bar, rotate automatic belt tensioner to the right to remove 6K drive belt.
5. Remove 6K automatic belt tensioner bolt and nuts.
6. Remove lower radiator hose and heater hose.

7. Remove crankshaft pulley and damper as outlined.
8. Disconnect crankshaft position (CKP) sensor (6C3 15) wiring harness from sensor and locating stud (FF only).

NOTE: Do not cut and seal oil pan gasket. Always replace with new rubber gasket.

9. Drain and remove oil pan as outlined. Discard removed gasket.
10. Remove retaining bolts from timing cover to block.

NOTE: The timing cover and water pump may be removed as an assembly by not removing bolt numbers 11 through 15 as shown.

Unleaded Gasoline Shown, FF Similar

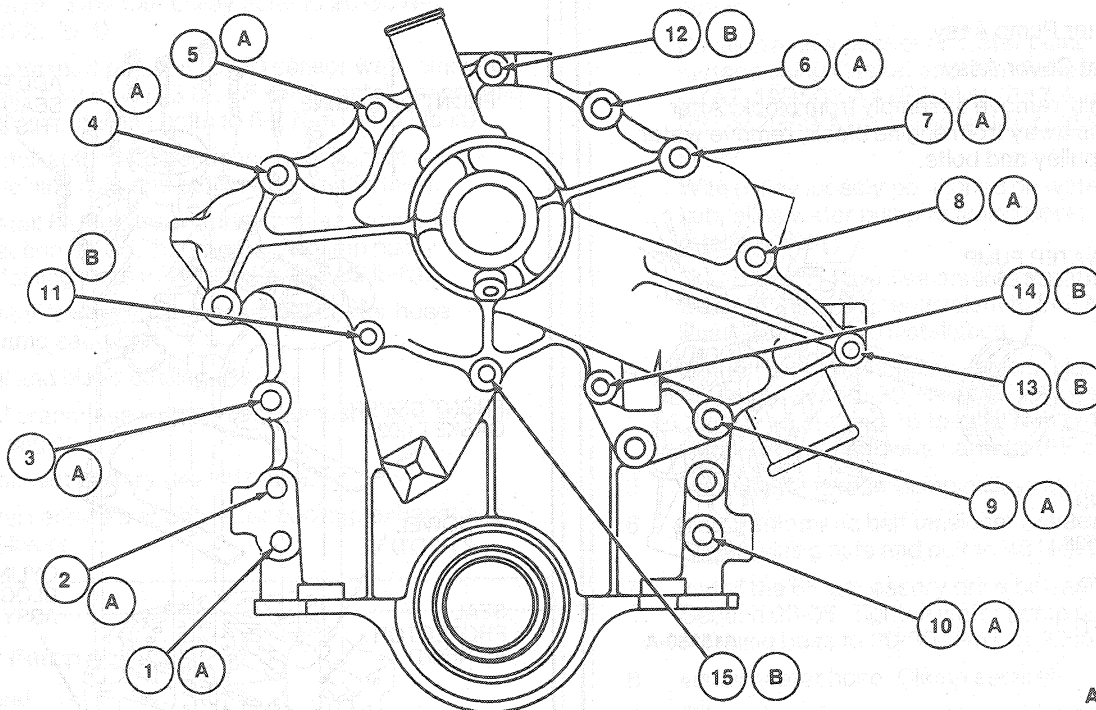

A13096-B

FASTENER AND HOLE NO.	FASTENERS			TORQUE SPECIFICATIONS	
	PART NO.	SIZE	FASTENER APPLICATION	N·m	LB-FT
1	N804113-S8	M8 x 1.25 x 43.5	F/C TO BLOCK	20-30	15-22
2	N804113-S100	M8 x 1.25 x 43.5	F/C TO BLOCK	20-30	15-22
3	N804811-S100	M8 x 1.25 x 70	W/P & F/C TO BLOCK	20-30	15-22
4	N804811-S8	M8 x 1.25 x 70	W/P & F/C TO BLOCK	20-30	15-22
5	N605909-S8	M8 x 1.25 x 42	F/C TO BLOCK	20-30	15-22
6	N804811-S8	M8 x 1.25 x 70	W/P & F/C TO BLOCK	20-30	15-22
7	N804811-S8	M8 x 1.25 x 70	W/P & F/C TO BLOCK	20-30	15-22

(Continued)