

SECTION 03-04A Fuel Charging and Controls—3.0L

SUBJECT	PAGE	SUBJECT	PAGE
ADJUSTMENTS.....	03-04A-22	REMOVAL AND INSTALLATION (Cont'd.)	
CLEANING AND INSPECTION		Fuel Injection Wiring Harness	03-04A-21
Idle Air Control (IAC) Valve	03-04A-22	Fuel Injector Manifold Assembly	03-04A-16
COMPONENTS		Fuel Pressure Regulator	03-04A-20
Fuel Injection Supply Manifold Assembly	03-04A-8	Fuel Pressure Relief Valve (Schrader Valve).....	03-04A-15
Fuel Injectors	03-04A-6	Fuel Sensor	03-04A-20
Fuel Pressure Regulator	03-04A-7	Idle Air Control (IAC) Valve Assembly	03-04A-14
Lower Intake Manifold Assembly	03-04A-8	Spring Lock Coupling	03-04A-8
Throttle Body (TB) Assembly	03-04A-7	Throttle Body (TB)	03-04A-11
DESCRIPTION		Throttle Position (TP) Sensor	03-04A-15
Fuel Metering Assembly Identification	03-04A-3	SPECIAL SERVICE TOOLS	03-04A-23
OPERATION	03-04A-3	SPECIFICATIONS	03-04A-22
PARTS CROSS-REFERENCE	03-04A-23	VEHICLE APPLICATION	03-04A-1
REMOVAL AND INSTALLATION			
Cold Start Injector (CSI)	03-04A-14		

VEHICLE APPLICATION

Taurus / Sable and Taurus equipped with 3.0L Flexible Fuel (FF) Engine.

DESCRIPTION

The sequential multiport fuel injection (SFI) system is classified as a multi-point, pulse time, mass air control, fuel injection system. Fuel is metered into each intake port in sequence with the engine firing order in accordance with engine demand through fuel injectors (9F593) mounted on a tuned intake manifold (9424).

WARNING: DO NOT SMOKE, CARRY LIGHTED TOBACCO, OR OPEN FLAME OF ANY TYPE WHEN WORKING ON OR NEAR ANY FUEL-RELATED COMPONENT. HIGHLY FLAMMABLE MIXTURES ARE ALWAYS PRESENT AND MAY BE IGNITED, RESULTING IN POSSIBLE PERSONAL INJURY.

NOTE: Fuel methanol refers to a blend of fuel with a maximum of 85 percent methanol.

WARNING: DO NOT SWALLOW FUEL METHANOL. LIKE GASOLINE, IT IS HIGHLY TOXIC AND IF SWALLOWED CAN CAUSE DEATH OR PERMANENT INJURY. SWALLOWING METHANOL CAN ALSO CAUSE BLINDNESS. CALL A PHYSICIAN IMMEDIATELY TO TREAT ANYONE WHO HAS SWALLOWED FUEL METHANOL. VOMITING SHOULD BE INDUCED BY OR UNDER THE DIRECTION OF A PHYSICIAN OR POISON CONTROL CENTER. BE AWARE THAT THE ONSET OF POTENTIAL ILL HEALTH EFFECTS MAY BE DELAYED.

AVOID INHALING FUEL VAPORS. INHALING TOO MUCH FUEL METHANOL OR GASOLINE VAPOR CAN LEAD TO EYE AND RESPIRATORY TRACT IRRITATION. IN SEVERE CASES, EXCESSIVE OR PROLONGED BREATHING OF FUEL METHANOL OR GASOLINE VAPORS CAN CAUSE SERIOUS ILLNESS AND PERMANENT INJURY SUCH AS BLINDNESS.

AVOID GETTING FUEL METHANOL OR GASOLINE LIQUID IN YOUR EYES. IF YOU GET ANY FUEL METHANOL OR GASOLINE IN YOUR EYES, REMOVE CONTACT LENSES (IF WORN), FLUSH IMMEDIATELY WITH PLENTY OF WATER FOR AT LEAST 15 MINUTES AND SEEK MEDICAL ATTENTION.

ALLOWING FUEL METHANOL OR GASOLINE TO GET IN YOUR EYES WILL CAUSE SEVERE IRRITATION. FAILURE TO SEEK PROPER MEDICAL ATTENTION FOR FUEL METHANOL OR GASOLINE CONTACT WITH THE EYES COULD LEAD TO PERMANENT INJURY SUCH AS BLINDNESS.

IF YOU GET FUEL METHANOL OR GASOLINE ON YOUR SKIN, WASH WITH SOAP AND WATER. REPEATED OR PROLONGED SKIN CONTACT WITH METHANOL OR GASOLINE LIQUID OR VAPOR CAUSES SKIN IRRITATION. MAKE SURE YOU WASH YOUR HANDS BEFORE HANDLING FOOD.

DESCRIPTION (Continued)

IF YOU ARE TAKING MEDICATION FOR THE TREATMENT OF ALCOHOLISM, SUCH AS ANTABUSE OR OTHER FORMS OF DISULFIRAM, SKIN CONTACT WITH FUEL METHANOL OR BREATHING ITS VAPORS CAN CAUSE THE SAME KIND OF ADVERSE REACTION AS DRINKING ALCOHOL. IN SENSITIVE INDIVIDUALS, SERIOUS PERSONAL INJURY OR SICKNESS COULD RESULT. IF YOU ARE TAKING SUCH MEDICATION, YOU SHOULD TAKE EXTRA CARE TO AVOID SKIN CONTACT WITH FUEL METHANOL AND TO AVOID BREATHING ITS VAPORS. IF YOU DO GET FUEL METHANOL ON YOUR SKIN, WASH IT OFF IMMEDIATELY. CONSULT A PHYSICIAN PROMPTLY IF YOU EXPERIENCE AN ADVERSE REACTION.

WARNING: DO NOT MODIFY THE FUEL SYSTEM CONFIGURATION OR COMPONENTS, OR REPLACE COMPONENTS WITH PARTS NOT ESPECIALLY DESIGNED FOR USE WITH FUEL METHANOL. FORD MOTOR COMPANY HAS SPECIALLY-DESIGNED THE MATERIALS, COMPONENTS AND SYSTEM CONFIGURATION FOR METHANOL-FUELED VEHICLES AND EACH PARTICULAR SYSTEM IS PRECISELY CALIBRATED FOR EFFICIENT OPERATION. THE USE OF DIFFERENT PARTS OR MATERIALS COULD PRODUCE AN UNTESTED CONFIGURATION THAT COULD RESULT IN FIRE, PERSONAL INJURY, OR COULD CAUSE ENGINE DAMAGE.

WARNING: DO NOT OPERATE ENGINE OR SMOKE WHILE REFUELING.

CAUTION: Use only fuel methanol which meets Ford Specification ESE-M4C97-B. Use of other fuel methanol may cause powertrain damage as well as loss of vehicle performance. It will also invalidate any extended service agreement.

WARNING: IT IS IMPORTANT THAT YOUR FLEXIBLE FUEL VEHICLE BE PROPERLY MAINTAINED BY FORD FLEXIBLE FUEL TRAINED PERSONNEL. IF A PROBLEM OCCURS, IT IS IMPORTANT THAT PROPERLY TRAINED PERSONNEL DIAGNOSE THE CAUSE. IF THE PROBLEM RELATES TO THE FUEL SYSTEM, PROPER PART REPLACEMENT IS IMPERATIVE TO KEEP YOUR VEHICLE OPERATING AT NORMAL PERFORMANCE. FLEXIBLE FUEL COMPONENTS AND STANDARD FUEL COMPONENTS ARE NOT INTERCHANGEABLE AND IF YOUR VEHICLE IS NOT SERVICED IN ACCORDANCE WITH FLEXIBLE FUEL VEHICLE PROCEDURES, DAMAGE MAY OCCUR AND YOUR WARRANTY MAY BE INVALIDATED.

What Is Fuel Methanol?

Fuel methanol is a mixture of 85 percent methanol and 15 percent unleaded gasoline. The Flexible Fuel (FF) vehicles are able to run on fuel methanol, gasoline or any mixture in between.

Below about 10°C (50°F), the methanol vapor pressure is too low to produce the flammable air / fuel mixture necessary to engine operation.

Adding a co-fuel such as gasoline brings the resulting air / fuel vapor back into the flammable range.

Methanol is more chemically active than gasoline. It corrodes some metals and may cause some plastic and rubber components to swell, or become brittle and crack. For this reason, only FF vehicle components specifically designed for use with fuel methanol should be used.

Advantages of Fuel Methanol

Methanol can be produced from a variety of resources including coal and natural gas. The abundant reserve of coal and natural gas in the United States gives fuel methanol the potential to be an important fuel of the future.

Methanol has a high-octane rating which can be used to improve engine performance and efficiency. Methanol is a clean-burning fuel, making it easier to meet emission standards. Being a liquid fuel used in internal combustion engines, the same basic service procedures used for gasoline engines also are used for engines operating on fuel methanol.

CAUTION: If fuel methanol is spilled onto a painted surface, flush surface with water immediately and allow to air dry. Do not attempt to wipe spilled fuel methanol with any form of cloth or towel as this may damage the paint.

An on-board vehicle powertrain control module (PCM) 12A650 accepts inputs from various engine sensors to compute the required fuel flow rate necessary to maintain a prescribed air / fuel ratio throughout the entire engine operational range. The PCM then outputs a command to the fuel injector to meter the appropriate quantity of fuel.

The PCM system also determines and compensates for the age of the vehicle and its uniqueness. The system will automatically sense and compensate for changes in altitude (i.e., from sea level to mountains) and will also permit push-starting the vehicle should it become necessary (manual transaxle only).

All engines use a closed-type positive crankcase ventilation (PCV) system and an exhaust emission system to control engine emissions within Government specifications.

To maintain the required exhaust emission levels, the fuel metering system must be kept in good operating condition and adjusted to specifications listed in the applicable Section of the Powertrain Control / Emissions Diagnosis Manual¹, the applicable Section of this Group, or on the Vehicle Emission Control Information (VECI) decal.

Additional engine performance checks are required to keep the exhaust emissions at the specified minimum pollutant level. Refer to the Pre-Delivery manual, Section 00-03 for these performance checks and recommended intervals.

This Section covers cleaning and inspection procedures.

For fuel system component removal, disassembly, assembly, installation and major service operations, refer to the applicable Section of this Group.

¹ Can be purchased as a separate item.

DESCRIPTION (Continued)

Always refer to the Master Parts List for parts usage and interchangeability before replacing a throttle body (9E926) or a component part of a throttle body.

Fuel Metering Assembly Identification

The base part number of the fuel metering assembly is 9E926. The base part number on 3.0L engine is located underneath the snowshield on the solenoid end of the idle air control (IAC) valve.

The "Unleaded Fuel Only" or "Fuel Methanol or Unleaded Fuel Only" nomenclature must appear:

- Near the fuel filler opening.
- On the instrument cluster.

BASE
PART
NUMBER

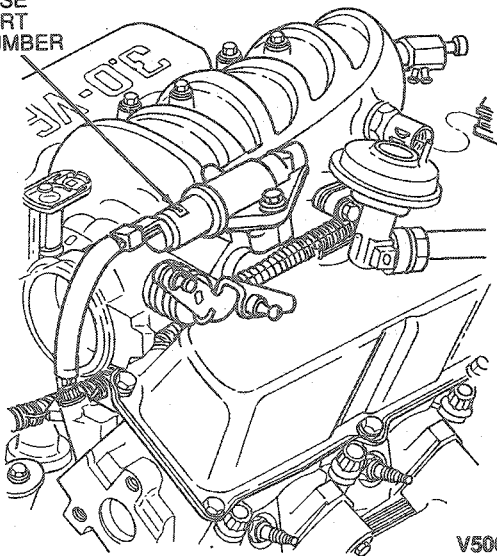

OPERATION

The SFI system can be sub-divided into four distinct categories:

- Fuel Delivery
- Air Induction
- Sensors
- Powertrain Control Module (PCM)

The fuel injectors are energized in the following sequence 1, 4, 2, 5, 3, 6. The period of time that the fuel injectors are energized (injector "on" time or the pulse width) is controlled by the vehicle's powertrain control module (PCM) 12A650. Air entering the engine is measured by a mass air flow (MAF) sensor 12B579. The resultant airflow information and input from various other engine sensors is used to compute the required fuel flow rate necessary to maintain a prescribed air/fuel ratio for the given engine operation. The PCM determines the needed fuel injector pulse width and outputs a command to the fuel injector to meter the exact quantity of fuel.

OPERATION (Continued)

Unleaded Gasoline Vehicles

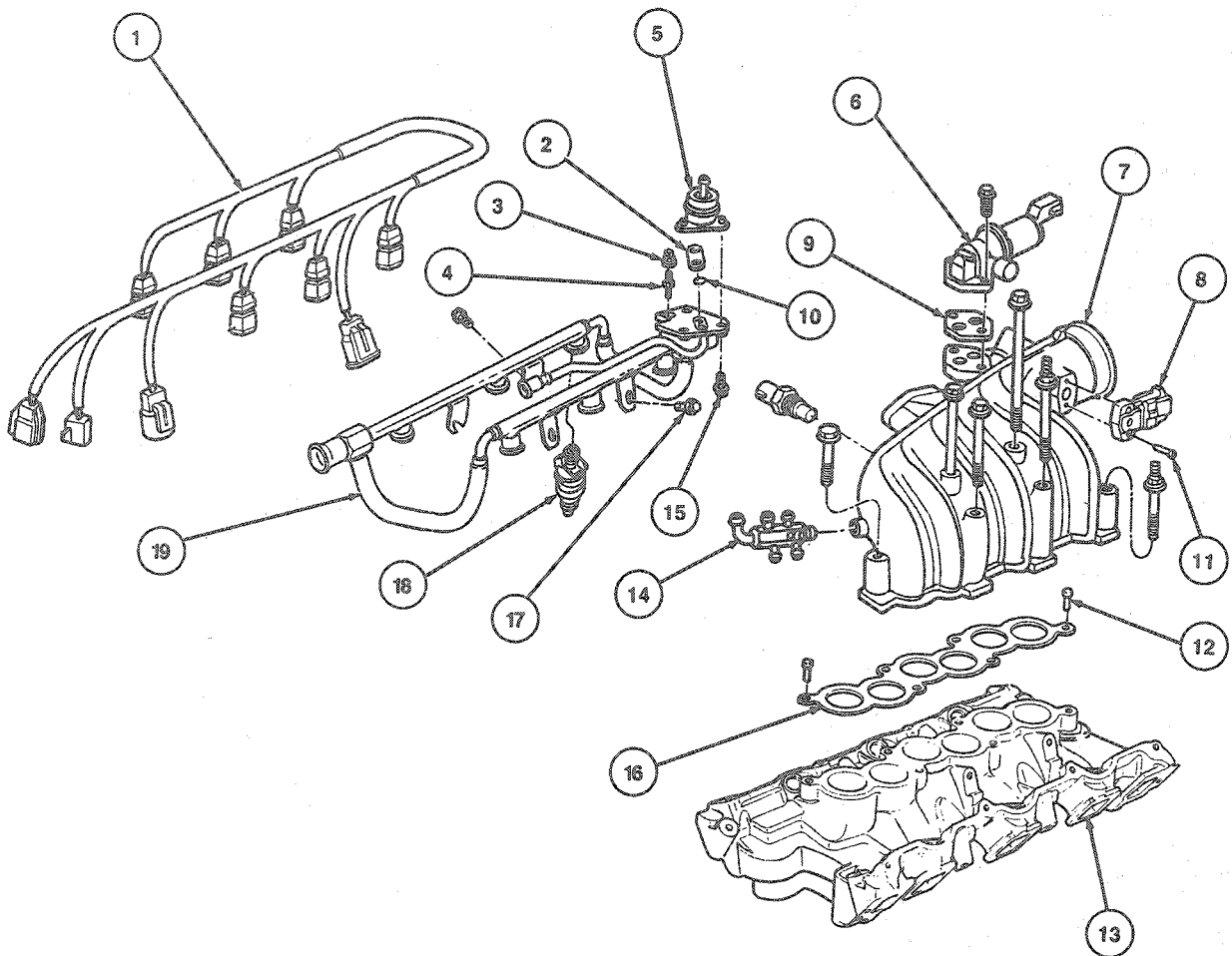

V7677-B

Item	Part Number	Description
1	9D930	Fuel Charging Wiring
2	9C977	Fuel Pressure Regulator Gasket
3	9H323	Fuel Pressure Relief Valve Cap
4	9H321	Fuel Pressure Relief Valve
5	9C968	Fuel Pressure Regulator
6	9F715	Idle Air Control Valve
7	9E926	Throttle Body
8	9B989	Throttle Position Sensor
9	9F670	Secondary Air Injection Bypass Valve Gasket
10	87006-S96	O-Ring Seal 5/16 X .070
11	N603257-S100	Screw Assy

(Continued)

Item	Part Number	Description
12	—	Guide Pin Assy (2 Places)
13	9424	Intake Manifold
14	9A474	Intake Manifold Vacuum Outlet Fitting and Cap
15	N802353-S101	Regulator Assy Holddown Screw
16	9H486	Intake Manifold Upper Gasket
17	N802626-S8-1986 N804394-S8M-1987	Fuel Rail Holddown Screw and Washer Assy
18	9F593	Fuel Injector
19	9F792	Fuel Injection Supply Manifold

OPERATION (Continued)

FF Vehicles

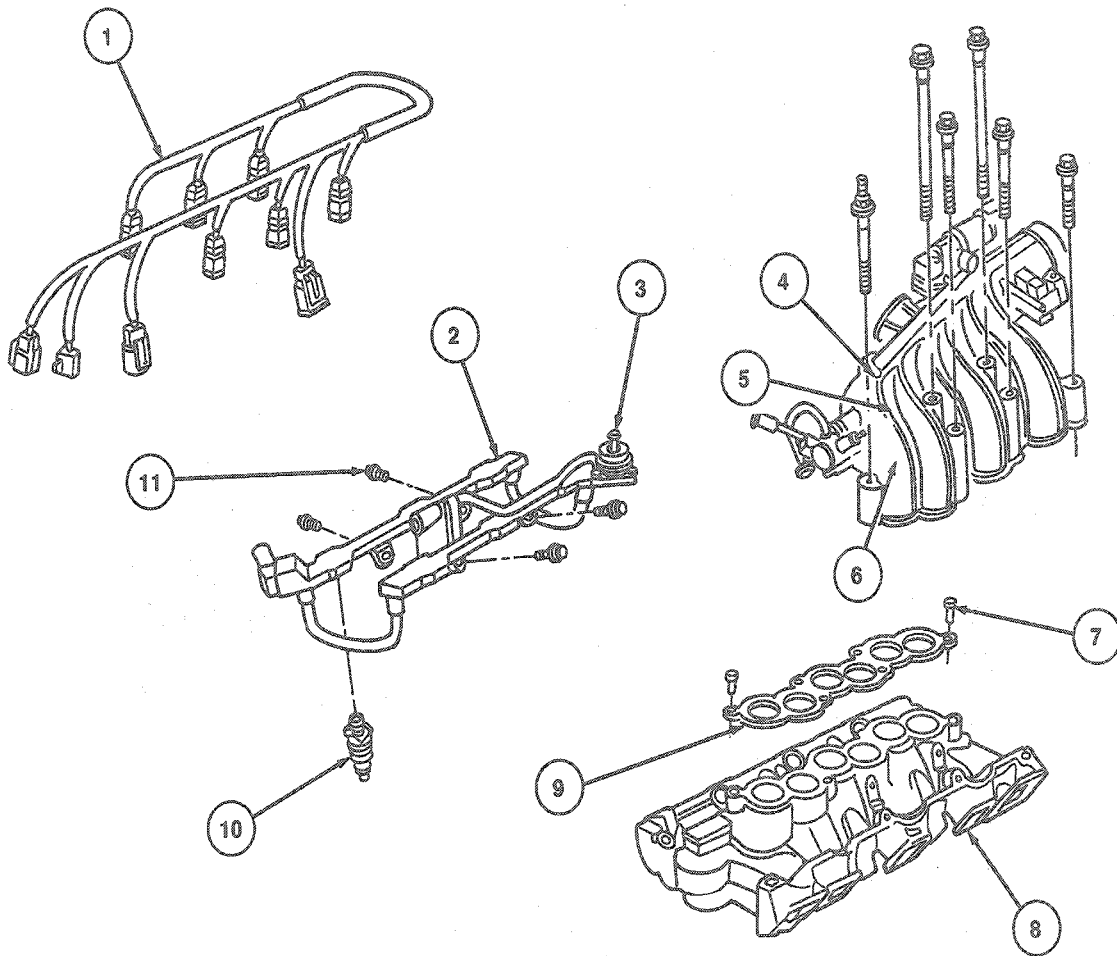

A16104-A

Item	Part Number	Description
1	9D930	Fuel Charging Wiring
2	9F792	Fuel Injection Supply Manifold
3	9C968	Fuel Pressure Regulator
4	9A474	Intake Manifold Vacuum Outlet Fitting and Cap
5	9E926	Throttle Body

(Continued)

Item	Part Number	Description
6	—	Cold Start Injector
7	—	Guide Pin
8	9424	Lower Intake Manifold
9	9H486	Intake Manifold Upper Gasket
10	9F593	Fuel Injector
11	—	Screw and Washer Assy (4 Req'd)

COMPONENTS

Fuel Injectors

The fuel injectors are electro-mechanical devices which both meter and atomize fuel delivered to the engine. The SFI fuel injectors are mounted in the lower intake manifold and positioned such that their tips are directing fuel just ahead of the engine intake valves. The valve body consists of a solenoid actuated valve assembly. Therefore, fuel flow to the engine is regulated only by how long the solenoid is energized. An electrical signal from the powertrain control module (PCM) activates the injector solenoid causing the needle to move inward off the seat, allowing fuel to flow through the orifice. Atomization of the fuel is obtained by contouring the needle at the point where the fuel separates.

Unleaded Gasoline Only

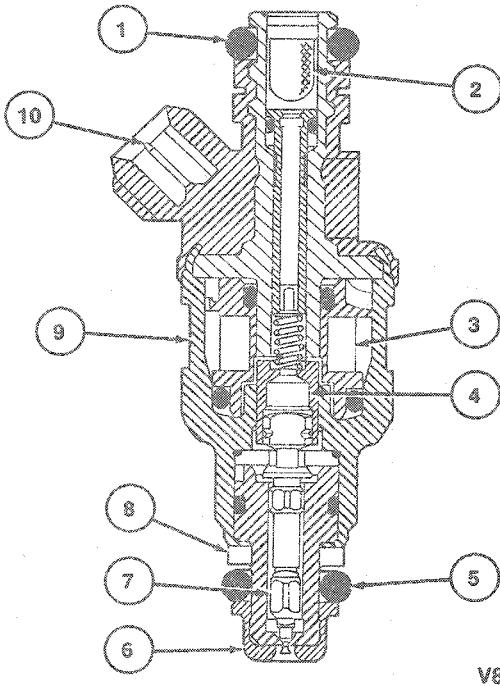

V8562-A

Item	Description
1	Fuel Injection Supply Manifold O-Ring Seal
2	Integral Filter
3	Coil
4	Armature
5	Intake Manifold O-Ring Seal
6	End Cap
7	Stainless Steel Needle and Valve Body
8	Washer
9	Low Carbon Steel Body
10	Electrical Connector

Fuel Injectors

The FF vehicle fuel injectors have a higher fuel flow rate than unleaded gasoline fuel injectors. They are methanol compatible and use methanol compatible O-rings.

FF ONLY

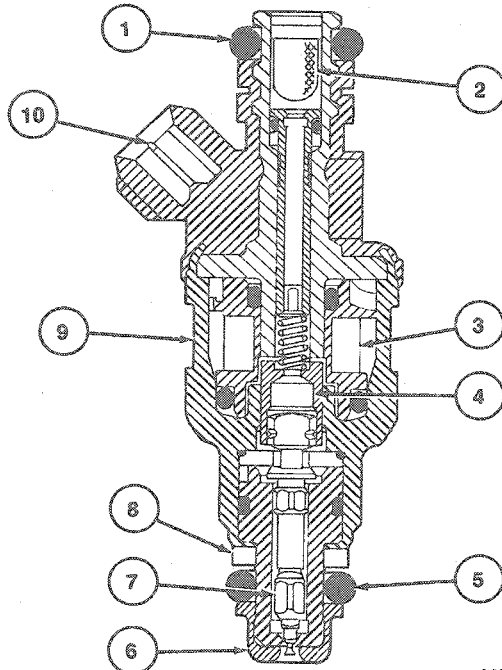

V8562-A

Item	Description
1	Fuel Injection Supply Manifold O-Ring Seal
2	Integral Filter
3	Coil
4	Armature
5	Intake Manifold O-Ring Seal
6	End Cap
7	Stainless Steel Needle and Valve Body
8	Washer
9	Stainless Steel Body
10	Electrical Connector

Cold Start System

The FF vehicles use a cold start injector (CSI) to provide additional fuel to improve cold weather starts. The CSI is mounted on the RH side of the throttle body assembly.

The cold start injector (CSI) is operated by the powertrain control module (PCM). When the powertrain control module (PCM) senses cold engine temperature it energizes the fuel injector and extra fuel is sprayed into the throttle body.

COMPONENTS (Continued)

The CSI assembly has a stainless steel housing that contains a bottom-feed fuel injector and spray bar with two fuel line connections. One connection is the fuel supply inlet to the CSI from the fuel pump (FP). The second line connection is the CSI outlet and the fuel supply inlet for the fuel injection supply manifold (9F792).

The fuel pressure relief valve (9H321) is located on the side of the CSI housing.

Refer to the illustration under Air Throttle body Assembly.

Fuel Pressure Regulator

NOTE: The flexible fuel pressure regulator (9C968) operates the same as the unleaded gasoline fuel pressure regulator. However, the internal components are strictly methanol compatible.

The fuel pressure regulator is attached to the fuel injection supply manifold assembly downstream of the fuel injector. It regulates the fuel pressure supplied to the fuel injectors. The fuel pressure regulator is a diaphragm-operated relief valve in which one side of the diaphragm senses fuel pressure and the other side is subjected to intake manifold pressure. The nominal fuel pressure is established by a spring preload applied to the diaphragm. Balancing one side of the diaphragm with manifold pressure maintains a constant fuel pressure drop across the fuel injector. Fuel, in excess of that used by the engine, is bypassed through the fuel pressure regulator and returned to the fuel tank.

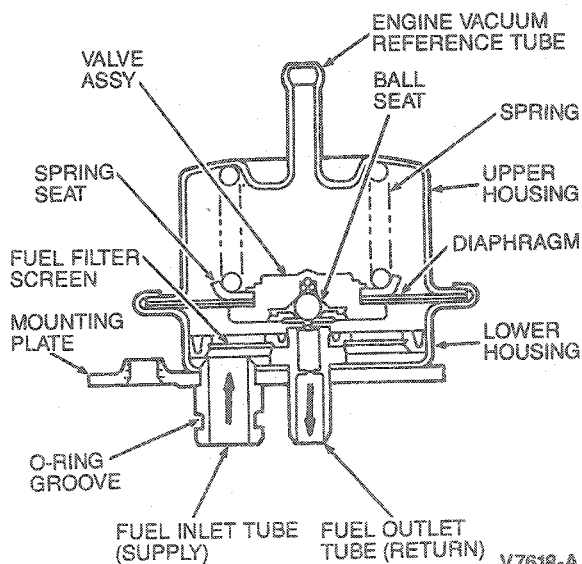

Throttle Body (TB) Assembly

The throttle body assembly controls airflow to the engine through a single butterfly-type valve. The throttle position is controlled by a conventional cable/four bar throttle linkage. The body is a single-piece ECP casting made of aluminum. It has a single bore with an air bypass channel around the throttle plate. This bypass channel controls both cold and warm engine idle airflow as regulated by an idle air control valve (IAC valve)(9F715) assembly mounted directly to the throttle body. The valve assembly is an electro-mechanical device controlled by the powertrain control module (PCM). It incorporates a linear actuator which positions a variable area metering valve.

Other features of the throttle body assembly include:

1. An adjustment screw to set the throttle plate at a minimum idle airflow position.
2. A pre-set stop to locate the WOT position.
3. A throttle body-mounted throttle position sensor (TP sensor)(9B989).
4. A positive crankcase ventilation (PCV) fresh air source located downstream of the throttle plate.
5. Individual ported vacuum taps (as required) for PCV and EVAP control signals.

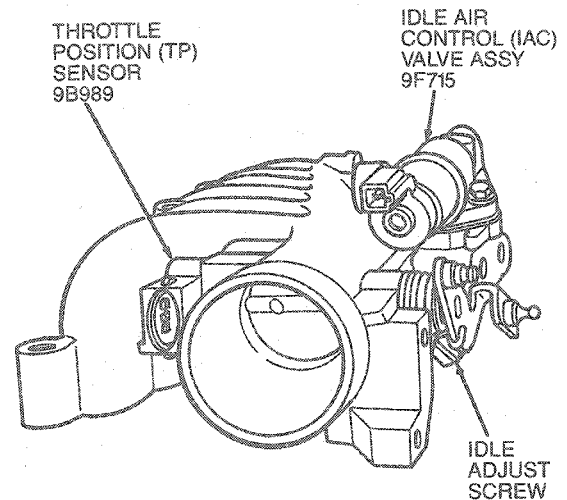

The FF vehicle throttle body has been modified for use with methanol fuel by the addition of a cold start injector (CSI).

COMPONENTS (Continued)

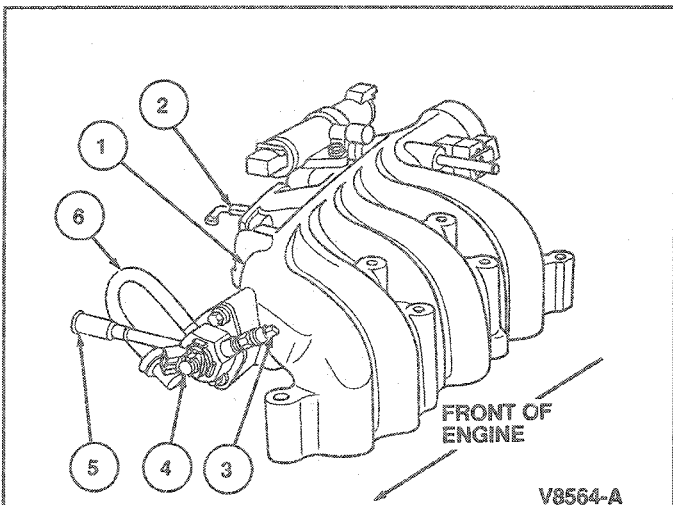

Item	Part Number	Description
1	9E926	Throttle Body
2	9A474	Intake Manifold Vacuum Outlet Fitting and Cap
3	9H321	Fuel Pressure Relief Valve
4	—	Cold Start Injector
5	—	Fuel Inlet Hose
6	—	Fuel Outlet Hose

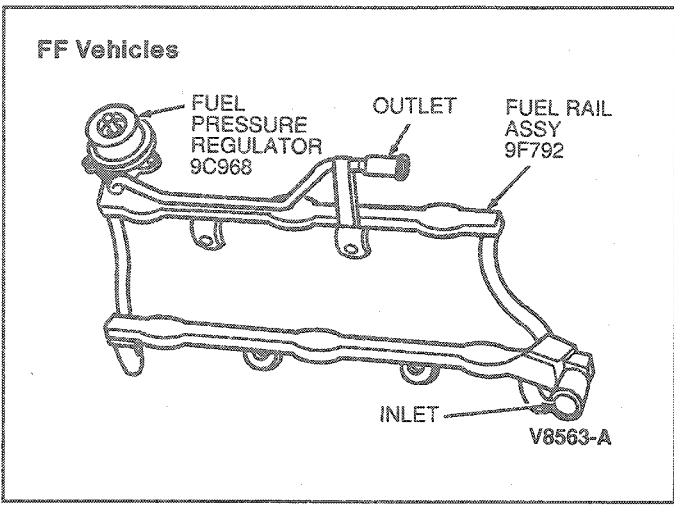

Lower Intake Manifold Assembly
 The lower intake manifold contains machined pockets for the fuel injectors to prevent both air and fuel leakage. The pockets, in which the fuel injectors are mounted, are placed to direct the injector fuel spray immediately in front of each engine intake valve.

REMOVAL AND INSTALLATION

Fuel Injection Supply Manifold Assembly
CAUTION: FF Vehicles' fuel supply manifold components are strictly methanol compatible.

The fuel injection supply manifold assembly is the component that delivers high-pressure fuel from the vehicle fuel supply line to the six fuel injector. The assembly consists of a single preformed tube or stamping with one injector connector for each fuel injector a mounting flange for the fuel pressure regulator a fuel pressure relief valve for diagnostic testing or field service fuel system pressure bleed down, and mounting attachments which locate the fuel injection supply manifold assembly and provide fuel injector retention.

Unleaded Gasoline Vehicles

Spring Lock Coupling
Tools Required:

- Spring Lock Coupling Disconnect Tool D87L-9280-A (3/8 inch) or D87L-9280-B (1/2 inch)

The spring lock coupling is a fuel line coupling held together by a garter spring inside a circular cage. When the coupling is connected together, the flared end of the female fitting slips behind the garter spring inside the cage of the male fitting. The garter spring and cage then prevent the flared end of the female fitting from pulling out of the cage. As a redundant locking feature, a horseshoe shaped retaining clip is incorporated to improve the retaining reliability of the spring lock coupling.

Removal

- Release fuel system pressure. Refer to Section 10-01 for fuel system pressure relief procedures. A fuel pressure relief valve on the fuel injection supply manifold assembly is provided for this procedure.

REMOVAL AND INSTALLATION (Continued)

2. Remove retaining clip from spring lock coupling by hand only. Do not use any sharp tool or screwdriver as it may damage the spring lock coupling.
3. Twist fitting to free it from any adhesion at the O-ring seals.
4. Fit Spring Lock Coupling Disconnect Tool D87L-9280-A (3/8 inch) or D87L-9280-B (1/2 inch) or equivalent to coupling.
5. Close tool and push into open side of cage to expand garter spring and release female fitting.
6. After garter spring is expanded, pull fittings apart.
7. Remove tool from disconnected coupling.

Installation

1. Ensure that garter spring is in cage of male fitting. If garter spring is missing, install a new spring by pushing it into cage opening. If garter spring is damaged, remove it from cage with a small wire hook (do not use a screwdriver) and install a new spring.
2. Clean all dirt or foreign material from both pieces of coupling.

WARNING: FF VEHICLES USE SPECIAL METHANOL COMPATIBLE O-RINGS.

3. Replace missing or damaged O-rings. Use only O-rings listed in Spring Lock Coupling illustration.

WARNING: USE ONLY THE SPECIFIED O-RINGS AS THEY ARE MADE OF A SPECIAL MATERIAL. THE USE OF ANY O-RING OTHER THAN THE SPECIFIED O-RING MAY ALLOW THE CONNECTION TO LEAK INTERMITTENTLY DURING VEHICLE OPERATION.

Lubricate male fitting and O-rings and inside of female fitting with clean engine oil XO-10W30-QSP (ESE-M2C153-E) or equivalent.

On FF vehicles use oil with an API designation of Multi-Fuel Vehicles (MFV).

4. Fit female fitting to male fitting and push until garter spring snaps over flared end of female fitting.
5. Ensure coupling engagement by pulling on fitting and visually checking to ensure garter spring is over flared end of female fitting.
NOTE: All vehicles require the large black clip to be installed on the supply side fuel line and the small gray clip to be installed on the return side fuel line.
6. Position retaining clip over metal portion of spring lock coupling. Firmly push retaining clip onto spring lock coupling. Ensure that horseshoe portion of clip is over the coupling. Do not install retaining clip over rubber fuel line.

REMOVAL AND INSTALLATION (Continued)

TO DISCONNECT COUPLING

CAUTION — RELIEVE FUEL PRESSURE BEFORE DISCONNECTING COUPLING

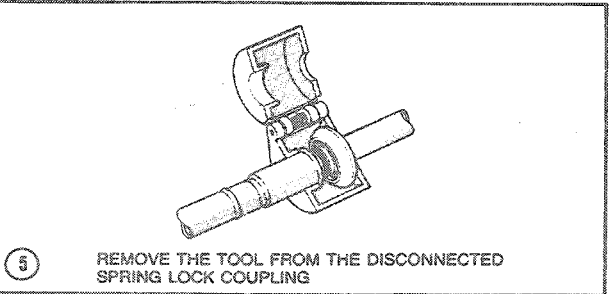
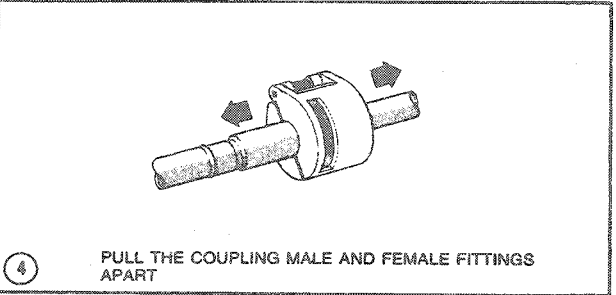
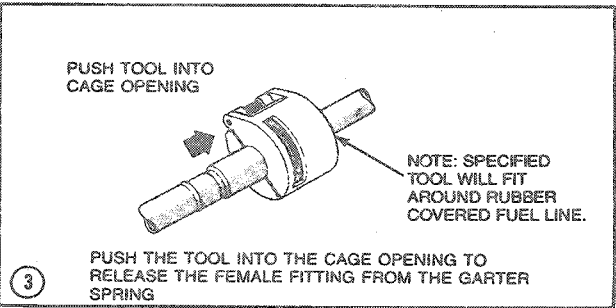
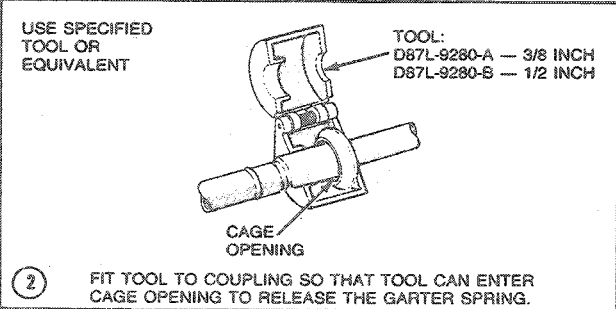
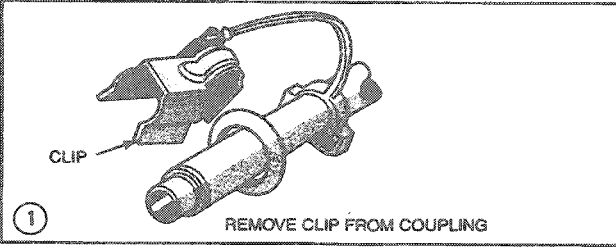

TO CONNECT COUPLING

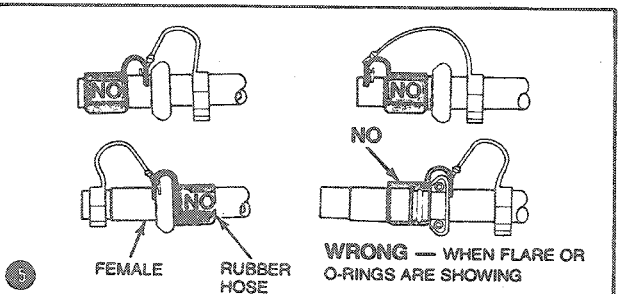
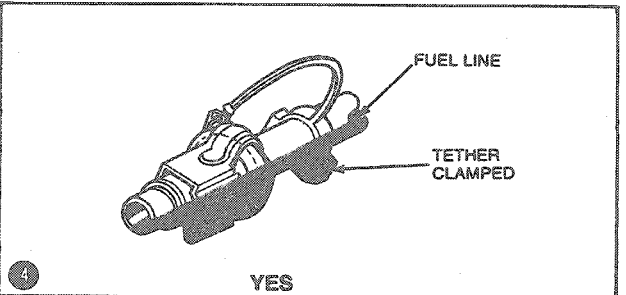
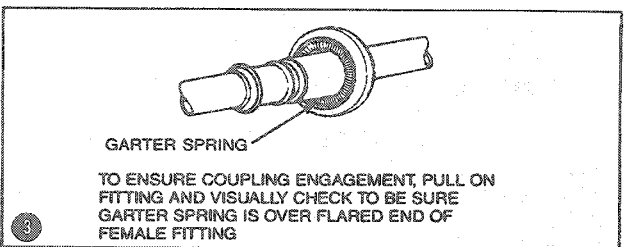
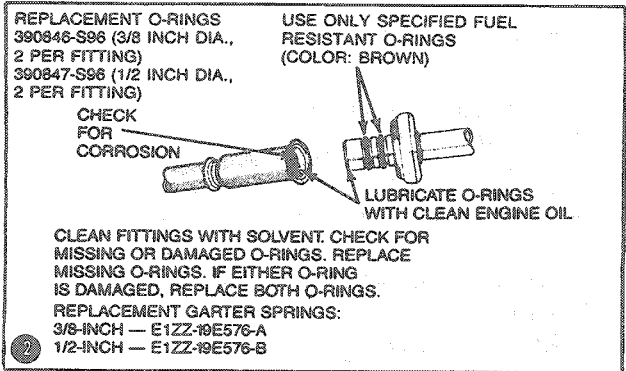
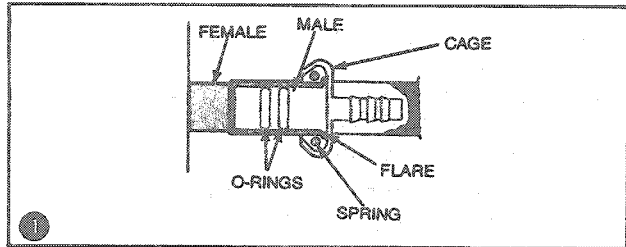

V7332-A

REMOVAL AND INSTALLATION (Continued)**Throttle Body (TB)****Unleaded Gasoline Vehicles****Removal**

1. Disconnect negative battery cable.
2. Loosen air cleaner duct hose retaining clamps and remove hose.
3. Remove idle air control (IAC) valve shield.
4. Disconnect throttle cable (9A758) and TV cable from throttle body linkage.

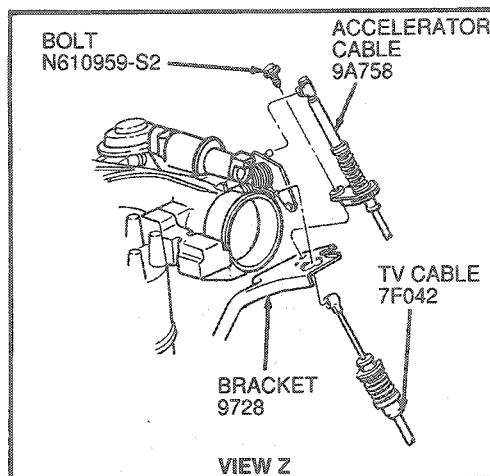
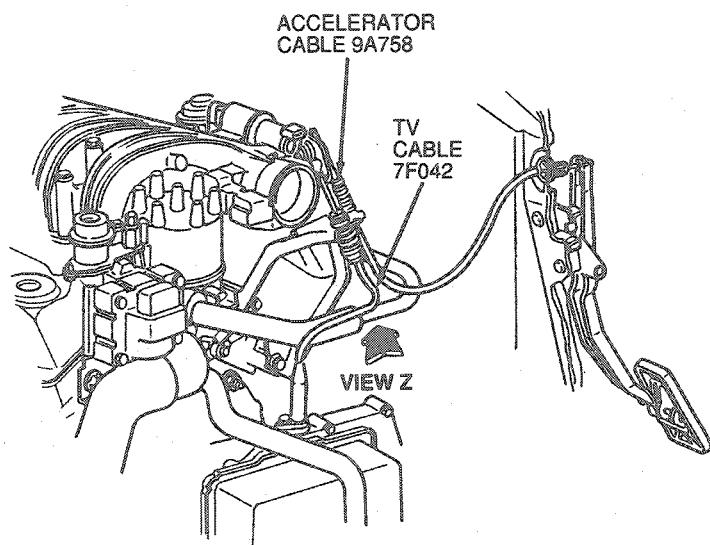

V4720-B

5. Mark location and remove vacuum hoses at vacuum tree.
6. Loosen EGR tube nuts if equipped at EGR valve (9D475) and exhaust manifold fitting. Remove or rotate tube out of the way.
7. Remove PCV hose from tube underneath throttle body.
8. Disconnect electrical connections to IAT, IAG and TP sensors.

9. Remove retaining nuts from generator brace and remove brace.
10. Loosen and remove the six throttle body retaining bolts (note location for installation).
11. Lift and remove throttle body assembly from intake manifold.
12. Discard old intake manifold upper gasket (9H486).

REMOVAL AND INSTALLATION (Continued)

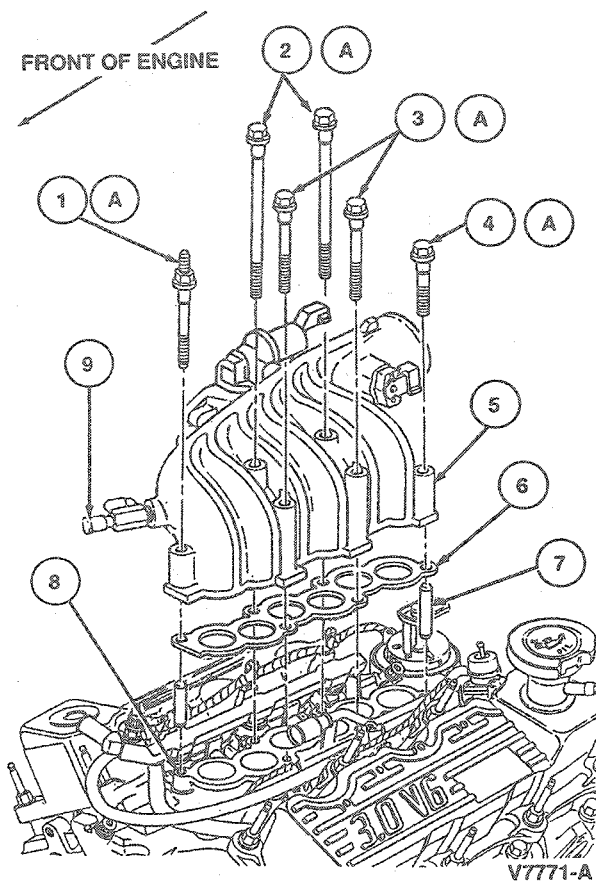

Item	Part Number	Description
1A	—	Stud Bolt
2A	—	Bolt-M8 x 1.25 x 130
3A	—	Bolt-M8 x 1.25 x 100
4A	—	Bolt-M8 x 1.25 x 68
5	9E926	Throttle Body
6	9H486	Intake Manifold Upper Gasket
7	—	Guide Pin
8	9424	Lower Intake Manifold
9	9A474	Intake Manifold Vacuum Outlet Fitting and Cap
A		Tighten to 20-30 N-m (15-22 Lb-Ft)

Installation

NOTE: Lightly oil all bolt and stud threads prior to installation.

- Clean and inspect sealing surfaces of intake manifold and throttle body.

CAUTION: Use care when cleaning gasket material as aluminum gouges easily which forms leak paths.

- Install guide pins as illustrated (if available).

- Place intake manifold upper gasket on intake manifold.
 - Aligning bolt holes, install throttle body on intake manifold. Install one stud bolt and five retaining bolts. Tighten to 20-30 N-m (15-22 lb-ft).
 - Install generator brace to throttle body and generator bracket. Tighten nuts to 16 N-m (12 lb-ft).
 - Connect PCV hose to tube underneath throttle body.
 - Install EGR tube to EGR valve and exhaust manifold fitting, if equipped. Tighten to 50 N-m (37 lb-ft).
 - Connect vacuum hoses to their pre-marked locations.
 - Connect electrical connections to IAT, IAC and TP sensor.
 - Connect throttle cable and TV cables to throttle body linkage.
 - Connect air cleaner duct hose to throttle body and air cleaner assembly. Tighten clamp to 4 N-m (36 lb-in).
 - Connect negative battery cable.
 - Start engine and check for vacuum leaks.
 - Check engine idle. Adjust as necessary as outlined in the Powertrain Control/Emissions Diagnosis Manual².
- NOTE: This adjustment must be performed if the throttle body is removed for any reason and if throttle plate idle adjustment screw position is changed.
- Adjust TV cable as outlined in Section 07-01.
 - Install shield onto idle air control (IAC). Tighten bolts to 1.4 N-m (13 lb-in).

Throttle Body

Flexible Fuel Vehicles

WARNING: DO NOT MODIFY THE FUEL SYSTEM CONFIGURATION OR COMPONENTS, OR REPLACE COMPONENTS WITH PARTS NOT SPECIALLY DESIGNED FOR USE WITH FUEL METHANOL. FORD MOTOR COMPANY HAS SPECIALLY-DESIGNED THE MATERIALS, COMPONENTS AND SYSTEM CONFIGURATION FOR METHANOL-FUELED VEHICLES AND EACH PARTICULAR SYSTEM IS PRECISELY CALIBRATED FOR EFFICIENT OPERATION. THE USE OF DIFFERENT PARTS OR MATERIALS COULD PRODUCE AN UNTESTED CONFIGURATION THAT COULD RESULT IN FIRE, PERSONAL INJURY, OR COULD CAUSE ENGINE DAMAGE.

Removal

- Disconnect negative battery terminal and set aside.
- Remove PCV closure and aspirator hoses from clean air flex tube.

² Can be purchased as a separate item.

REMOVAL AND INSTALLATION (Continued)

3. Loosen clean air flex tube retaining clamp at throttle body and disconnect tube.
4. Relieve pressure at the fuel pressure relief valve.
WARNING: COVER VALVE WITH SHOP CLOTH TO PREVENT ACCIDENTAL FUEL SPRAY INTO EYES.
5. Disconnect fuel supply hoses to cold start injector (CSI).
6. Remove idle air control (IAC) solenoid snowshield.
7. Disconnect throttle cable from throttle body.
8. Remove two throttle cable bracket retaining bolts from side of throttle body and remove bracket.
9. Mark location and remove vacuum hoses attached to vacuum tree and EGR valve.
10. Disconnect differential pressure feedback (DPFE) sensor hoses from EGR tube nipples.
11. Loosen EGR tube nut at EGR valve.
12. Remove vapor purge hose from fitting near throttle position sensor.
13. Disconnect electrical connections to idle air control (IAC), differential pressure feedback (DPFE), cold start injector (CSI) and throttle position sensors.
14. Remove generator brace retaining nuts from generator bracket and throttle body stud. Remove brace.
15. Loosen and remove five throttle body retaining bolts and stud bolt noting their locations.
16. Lift throttle body straight up and remove PCV hose from tube beneath assembly. Maneuver throttle body away from EGR tube and remove assembly. Discard old intake manifold upper gasket.
17. Cover intake manifold ports to prevent foreign material from entering manifold.

NOTE: The throttle body is to be replaced as an assembly only for the FF vehicle. Reuse original vacuum tree, EGR valve and DPFE assembly with new throttle body.

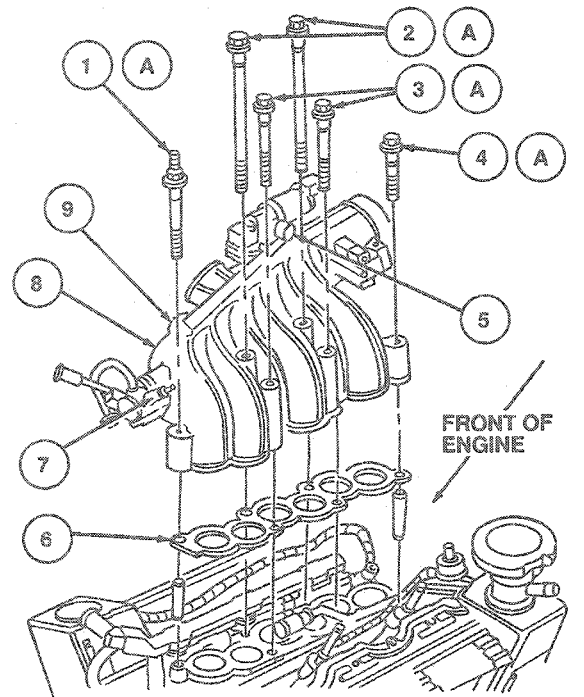

A16353-A

Item	Part Number	Description
1A	—	Stud Bolt
2A	—	Bolt M8 X 1.25 X 130 (2 Req'd)
3A	—	Bolt M8 X 1.25 X 100 (2 Req'd)
4A	—	Bolt
5	—	Purge Port
6	9E926	Throttle Body
7	—	Cold Start Injector
8	9E926	Throttle Body
9	9A474	Intake Manifold Vacuum Outlet Fitting and Cap
A		Tighten to 25 N·m (19 Lb·Ft)

Installation

NOTE: Lightly oil all bolt and stud threads prior to installation.

1. Clean and inspect sealing surfaces of intake manifold and throttle body.
CAUTION: Use care when cleaning gasket surfaces as aluminum gouges easily which forms leak paths.
2. Install guide pins if available in front and rear bolt holes.
3. Place new intake manifold upper gasket over guide pins.

REMOVAL AND INSTALLATION (Continued)

4. Aligning bolt holes, lower assembly enough to install PCV hose to tube beneath throttle body. Align EGR tube nut to EGR valve and lower assembly onto intake manifold. Start EGR tube nut engagement to EGR valve. Install four center retaining bolts and hand tighten. Remove guide pins. Install stud bolt and remaining retaining bolt. Tighten retaining bolts to 20-30 N·m (15-22 lb-ft) in sequence as illustrated.
5. Install generator brace to throttle body and generator bracket. Tighten nuts to 12-20 N·m (9-15 lb-ft).
6. Tighten EGR tube nut to 35-65 N·m (26-48 lb-ft).
7. Connect DPFE sensor hoses to EGR tube nipples. Check for cracked or deformed condition and replace as necessary.
8. Connect premarked vacuum lines to their original locations. Check for cracked or deformed condition and replace as necessary.
9. Connect electrical connections to TP, DPFE, CSI and IAC sensors.
10. Install vapor purge hose to fitting near TP sensor.
11. Install throttle cable bracket to side of throttle body. Tighten retaining bolts to 17 N·m (13 lb-ft).
12. Connect throttle cable and TV cable to throttle body lever.
13. Connect fuel supply tubes to CSI assembly.
14. Install clean air flex tube to throttle body. Tighten retaining clamp to 2.7-4.5 N·m (24-48 lb-in). Connect PCV closure and aspirator hose to their original locations.
15. Connect negative battery terminal.
16. Start engine and check for vacuum, exhaust and fuel leaks.
17. Check engine idle. Adjust as necessary. Refer to the Powertrain Control/Emissions Diagnosis manual.³
18. Install snowshield onto IAC valve. Tighten retaining screw to 8-12 N·m (6-8 lb-ft).

Cold Start Injector (CSI)**Removal and Installation**

1. Remove flexible fuel throttle body as outlined.
2. Remove two bolts retaining CSI spray bar assembly (9F880) to throttle body.
3. Remove CSI and gasket from throttle body.
4. Using a 1/4 inch allen wrench, remove plug located on throttle body opposite CSI mounting surface.

³ Can be purchased as a separate item.

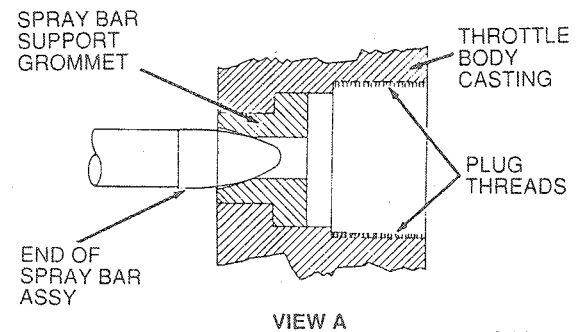
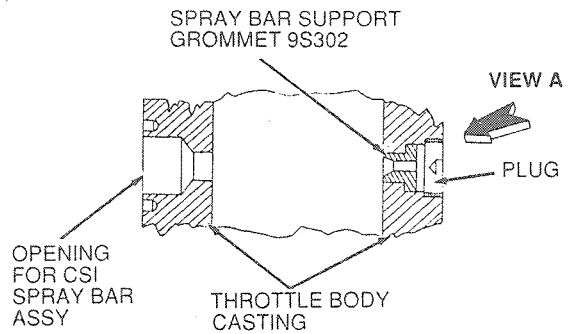

V8651-A

CAUTION: Use care when installing spray bar to throttle body. DO NOT FORCE or damage to CSI and spray bar assembly will occur.

5. Install CSI and spray bar assembly with new gasket (9P849) to throttle body, with end of spray bar assembly (9F880) resting in support grommet located behind plug in throttle body casting.
6. Align CSI to throttle body and install retainer bolts. Tighten bolts to 8-11 N·m (70-97 lb-in).
7. Verify that end of spray bar is resting in support grommet. If not, repeat Steps 1 through 6.
8. Apply Pipe Sealant with Teflon® D8AZ-19544-A (ESG-M4G194-A) or equivalent in a clockwise direction to plug and install plug in throttle body. Tighten plug to 10-15 N·m (7-11 lb-ft).
9. Reinstall throttle body as outlined. Inspect for leaks with engine running.

Idle Air Control (IAC) Valve Assembly**Removal**

1. Disconnect idle air control (IAC) valve assembly connector from wiring harness.

REMOVAL AND INSTALLATION (Continued)

- Remove two idle air control (IAC) valve retaining screws.

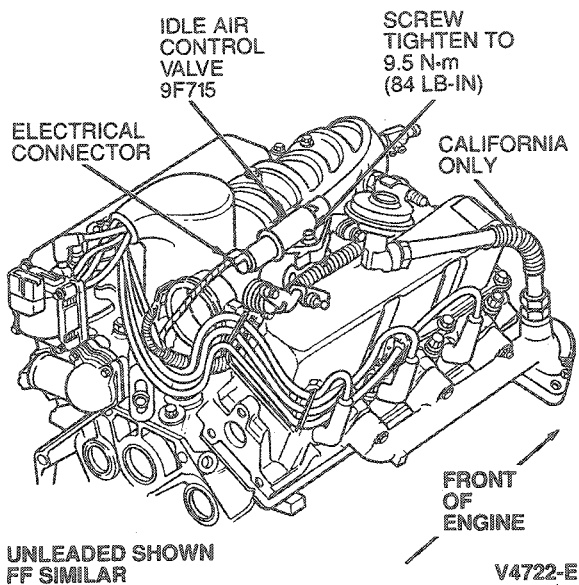

- Remove idle air control valve and gasket.
NOTE: If scraping is necessary, be careful not to damage idle air control valve or gasket surfaces, or drop material into throttle body.

Installation

- Ensure that both throttle body and idle air control (IAC) valve gasket surfaces are clean.
- Install gasket on throttle body surface and mount idle air control (IAC) valve assembly, securing it with two retaining screws. Tighten to 9.5 N·m (84 lb-in).
- Connect electrical connector for idle air control (IAC) valve.

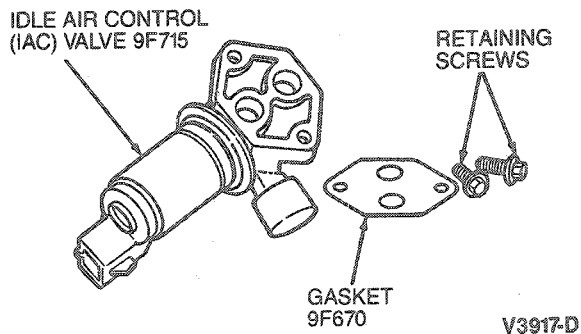

Throttle Position (TP) Sensor

Removal

- Disconnect throttle position sensor from wiring harness.
- Remove two throttle position sensor retaining screws.
- Remove throttle position sensor.

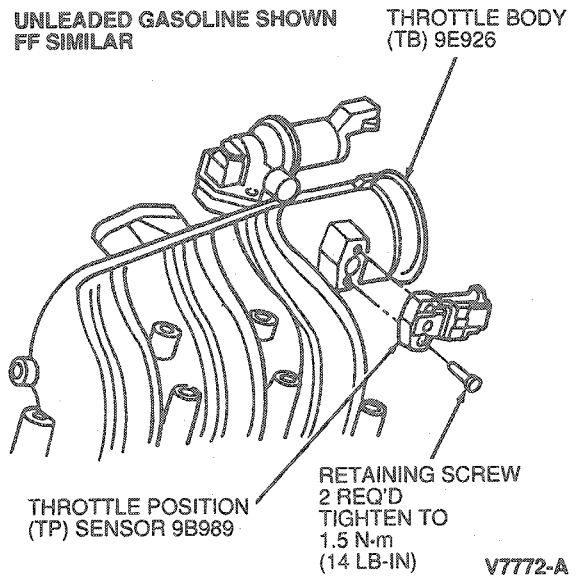

Installation

CAUTION: Slide rotary tangs into position over throttle shaft blade, then rotate throttle position sensor clockwise to installed position only. Failure to install the throttle position sensor in this manner may result in excessive idle speeds.

- Install throttle position sensor. Ensure that rotary tangs on sensor are in proper alignment and that the red seal is inside the connector housing.
NOTE: This throttle position sensor is not adjustable.
- Secure throttle position sensor to throttle body assembly with two retaining screws. Tighten to 1.5 N·m (14 lb-in).
- Connect electrical connector to harness.

Fuel Pressure Relief Valve (Schrader Valve)

Tools Required:

- Fuel Pressure Gauge T80L-9974-B

REMOVAL AND INSTALLATION (Continued)

Removal

1. If fuel rail assembly is mounted to engine, remove fuel tank cap, then release pressure from system at fuel pressure relief valve on fuel injection manifold or, cold start injector (FF vehicles only), using Fuel Pressure Gauge T80L-9974-B.

NOTE: Fuel pressure relief valve cap (9H323) on fuel pressure relief valve must be removed.

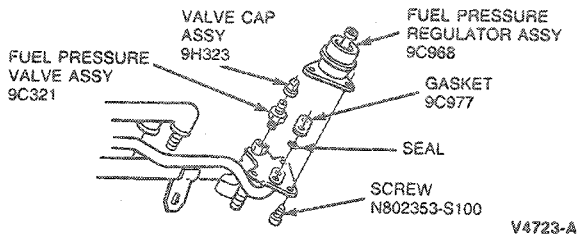

2. Using an open-end wrench or suitable deep well socket, remove fuel pressure relief valve.

Installation

Install fuel pressure relief valve and fuel pressure relief valve cap. Tighten valve to 7.75 N-m (66 lb-in) and the cap to 0.6 N-m (5.5 lb-in).

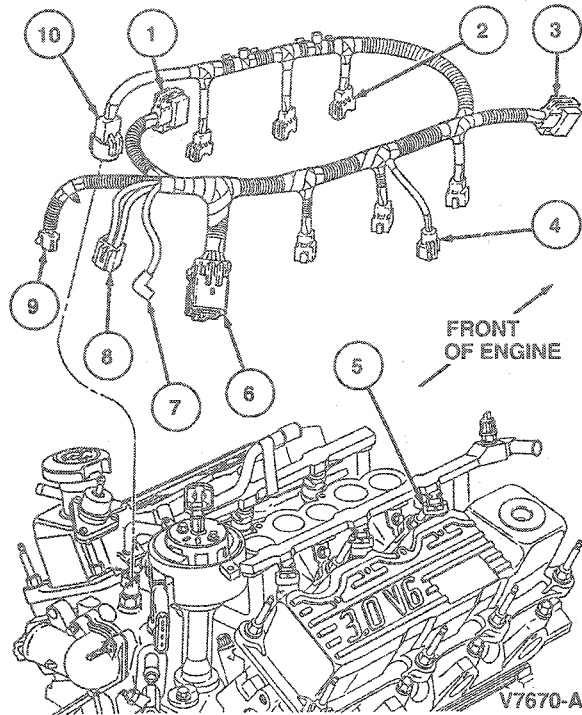

Fuel Injector Manifold Assembly

Unleaded Vehicles

Removal

1. Remove throttle body as outlined.

NOTE: Prior to fuel injection supply manifold removal, perform the following steps.

 - Scribe an alignment mark on base of distributor and lower intake manifold.
 - Remove distributor hold-down clamp.
 - Lift distributor enough to allow fuel injection supply manifold to clear distributor housing and lower intake manifold.
2. Disconnect fuel supply and fuel return lines as described under Fuel Metering and Air Intake / Throttle Body Components, Removal and Installation.
3. Carefully disconnect fuel charging wiring (9D930) from fuel injector.

Item	Part Number	Description
1	—	To Throttle Position Sensor
2	9D930	Fuel Charging Wiring
3	—	To DPFE Transducer Assy
4	—	To Air Charge Temperature Sensor
5	9F593	Fuel Injector (6 Req'd)
6	12A581	To Harness Assy
7	—	To Oil Pressure Switch Assy
8	—	TO EGR Vacuum Regulator Assy
9	—	To Idle Air Control
10	—	To Engine Coolant Temperature Sensor

4. Disconnect vacuum line from fuel pressure regulator.
5. Remove four fuel injector manifold retaining bolts (two on each side).

REMOVAL AND INSTALLATION (Continued)

Unleaded Gasoline Shown
FF Similar

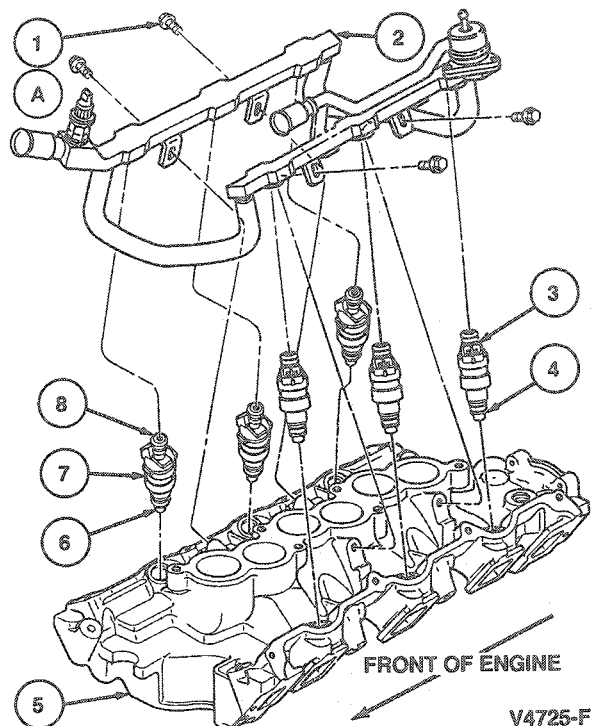

Item	Part Number	Description
1A	—	Screw and Washer Assy - M6 x 1 X 22 Hex Head (4 Req'd)
2	9F792	Fuel Injection Supply Manifold
3	—	Upper O-Ring Seal
4	—	Lower O-Ring Seal
5	9424	Lower Intake Manifold
6	—	Outlet End
7	9F593	Fuel Injector
8	—	Inlet End
A	—	Tighten to 10 N·m (7 Lb·Ft)

6. Carefully disengage fuel injection supply manifold assembly from fuel injector by lifting and gently rocking the rail.

CAUTION: Fuel injector and fuel injection supply manifold must be handled with extreme care to prevent damage to sealing areas and sensitive fuel metering orifices.

7. Remove fuel injector by lifting while gently rocking side to side.
8. Place removed components in a clean container to avoid dirt or other contamination.

Installation

NOTE: When installing fuel injection supply manifold assemblies with new or used fuel injectors particular attention should be paid to proper O-ring seating to ensure that no fuel leaks exist.

1. Examine injector O-rings for deterioration. Install new O-rings if required.
2. Lubricate new O-rings and install two on each injector using clean engine oil XO-10W30-QSP (ESE-M2C153-E) or equivalent.
3. Ensure injector cups are clean and free of contamination or damage.
4. Install fuel injectors in fuel rail using light twisting-pushing motion.

NOTE: Prior to installation perform the following steps:

- Lift distributor enough to allow fuel injection supply manifold to clear distributor housing and lower intake manifold and position fuel injection supply manifold.
 - Lower distributor into position.
 - Install distributor hold down clamp and align scribe marks. Tighten hold down clamp bolt to 24 N·m (18 lb-ft)
5. Carefully install fuel injection supply manifold assembly and Fuel Injectors into lower intake manifold, one side at a time. To ensure that O-rings are seated, push down on fuel injection supply manifold.
 6. While holding fuel injection supply manifold assembly in place, install two retaining bolts and tighten to 10 N·m (7 lb-ft).
 7. Before connecting the fuel charging wiring, turn ignition switch to the ON position. This will pressurize the fuel system.
 8. Using a clean paper towel, check for leaks where the fuel injector connects to the fuel injection supply manifold. If leaks are detected, service as required.
 9. Connect the fuel charging wiring and start the engine, let it idle for two minutes.
 10. Using a clean paper towel, check for leaks where the fuel injector is installed into intake manifold.
 11. Connect fuel supply (1/2 inch) and fuel return (3/8 inch) lines as outlined in this Section.
 12. Connect fuel fuel charging wiring at fuel injector.
 13. Connect vacuum line to fuel pressure fuel pressure regulator.
 14. Install air intake throttle body as outlined.

REMOVAL AND INSTALLATION (Continued)

FF Vehicles

Removal

WARNING: DO NOT MODIFY THE FUEL SYSTEM CONFIGURATION OR COMPONENTS, OR REPLACE COMPONENTS WITH PARTS NOT SPECIALLY DESIGNED FOR USE WITH FUEL METHANOL. FORD MOTOR COMPANY HAS SPECIALLY-DESIGNED THE MATERIALS, COMPONENTS AND SYSTEM CONFIGURATION FOR METHANOL-FUELED VEHICLES AND EACH PARTICULAR SYSTEM IS PRECISELY CALIBRATED FOR EFFICIENT OPERATION. THE USE OF DIFFERENT PARTS OR MATERIALS COULD PRODUCE AN UNTESTED CONFIGURATION THAT COULD RESULT IN FIRE, PERSONAL INJURY, OR COULD CAUSE ENGINE DAMAGE.

NOTE: Clean contaminants away from all components.

1. Remove throttle body as outlined.
2. Carefully disconnect fuel charging wiring from fuel injector.

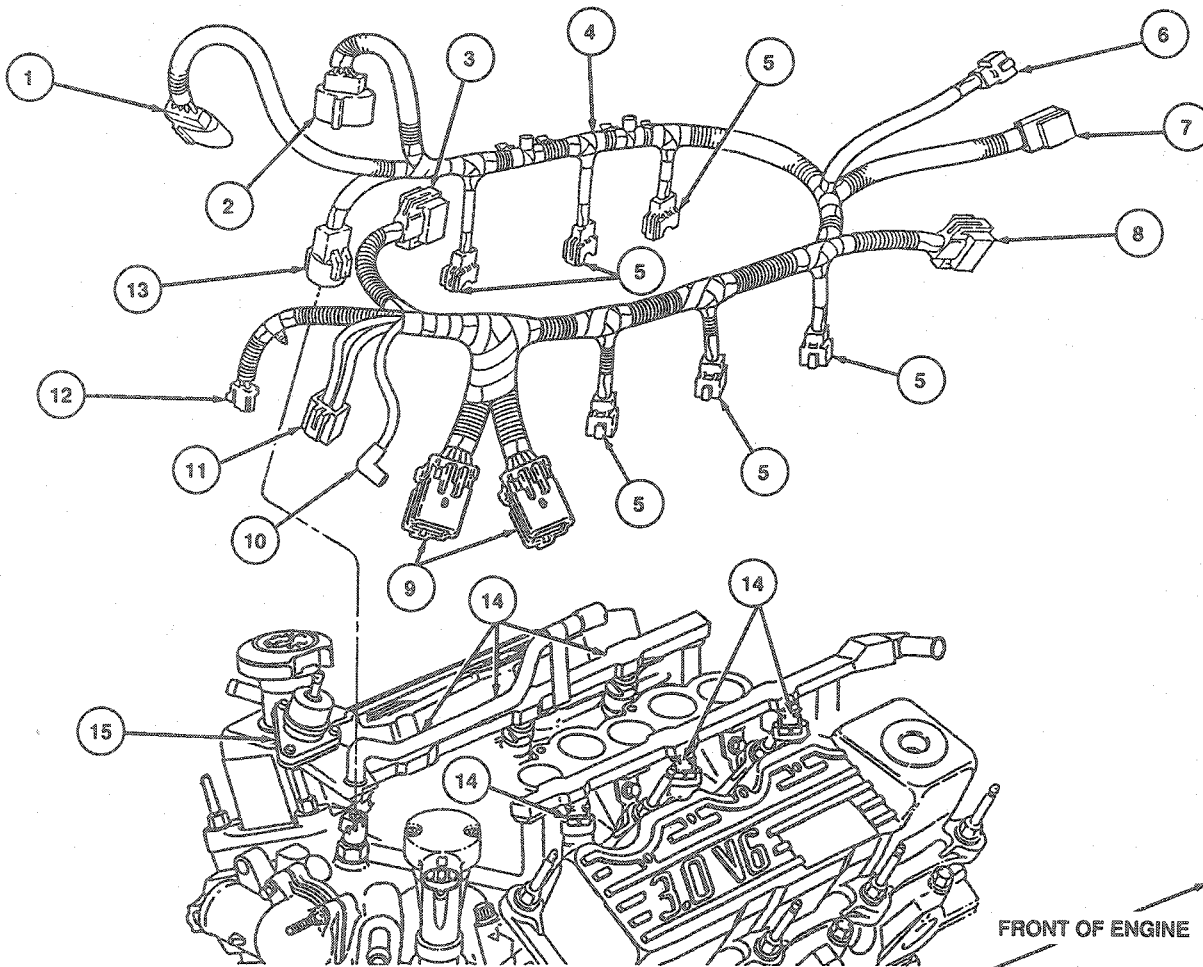

V7758-A

Item	Part Number	Description
1	—	To Synchronizer Assy
2	—	To Ignition Coil

(Continued)

Item	Part Number	Description
3	—	To TP Sensor
4	9D930	Fuel Charging Wiring

(Continued)

REMOVAL AND INSTALLATION (Continued)

Item	Part Number	Description
5	—	To Fuel Injector
6	—	To CSI
7	—	To Crankshaft Position CKP Sensor
8	—	To DPFE Sensor
9	—	To 12A581 Harness

(Continued)

Item	Part Number	Description
10	—	To Oil Pressure Switch
11	—	To EVR
12	—	To Idle Air Control (IAC)
13	—	To ECT
14	—	Fuel Injector
15	9F792	Fuel Injection Supply Manifold

3. Disconnect vacuum line from fuel pressure regulator.
4. Remove four fuel injection supply manifold retaining bolts (two on each side).
5. Carefully disengage fuel injection supply manifold assembly from fuel injectors by lifting and gently rocking the fuel injection supply manifold.
6. Remove fuel injectors by lifting while gently rocking side-to-side.

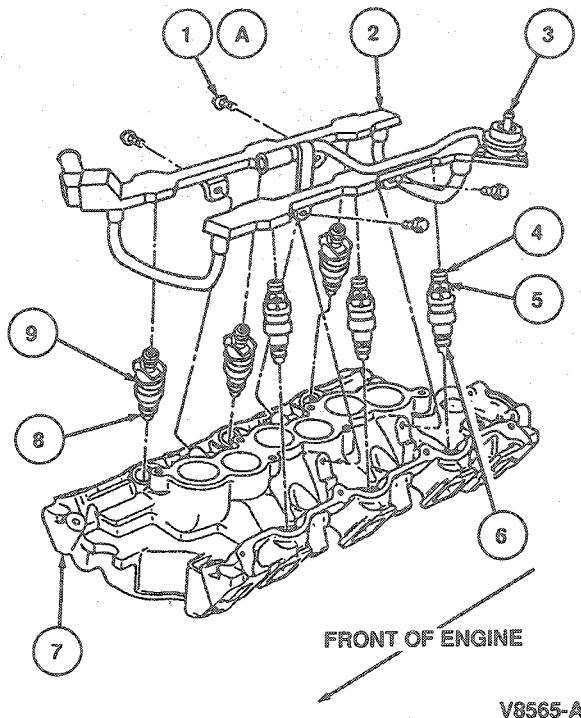

Item	Part Number	Description
1A	—	Screw and Washer Assy (4 Req'd)
2	9F792	Fuel Injection Supply Manifold
3	—	Fuel Pressure Regulator
4	—	Inlet End
5	—	Upper O-Ring Seal

(Continued)

Item	Part Number	Description
6	—	Lower O-Ring Seal
7	9424	Lower Intake Manifold Outlet End
8	—	Fuel Injector
9	9F593	Tighten to 8-12 N·m (6-8 Lb·Ft)
A	—	

7. Place removed components in a clean container to avoid dirt or other contamination.

CAUTION: Fuel injector and fuel injection supply manifold must be handled with extreme care to prevent damage to sealing areas and sensitive fuel metering orifices.

Installation

NOTE: When installing fuel injection supply manifold assemblies with new or used fuel injectors particular attention should be paid to proper O-ring seating to ensure that no fuel leaks exist.

WARNING: TO AVOID CUTTING O-RINGS, DO NOT ATTEMPT TO INSTALL THEM IF THEY ARE SWOLLEN. ALLOW THEM TO DRY OUT FIRST.

NOTE: Use only fuel methanol compatible O-rings when replacement is necessary.

1. Examine injector O-rings for deterioration or excessive swelling. Install new O-rings if required.
2. Install upper and lower O-rings on each fuel injector. Lubricate outer surface of O-rings with 2 to 3 drops of mineral oil.
3. Ensure injector cups are clean and free of contamination or damage.
4. Install fuel injector in lower intake manifold using light twisting-pushing motion.
5. Position fuel injection supply manifold cups over each fuel injector.
6. Carefully push fuel injection supply manifold fully down onto fuel injector one at a time. To ensure that O-rings are fully seated, twist each injector back and forth several times.
7. Holding fuel injection supply manifold assembly in fully down position, install four retaining bolts and tighten to 10 N·m (7 lb·ft).
8. Connect fuel charging wiring to fuel injectors.
9. Connect vacuum line to fuel pressure regulator.

REMOVAL AND INSTALLATION (Continued)

10. Install throttle body as outlined.
11. Connect fuel supply (1/2 inch) to cold start injector, fuel rail inlet and fuel return (3/8 inch) lines as outlined.
12. Before connecting the fuel charging wiring to vehicle harness, turn ignition switch to the ON position to pressurize the fuel system.
13. Using a clean paper towel and rubber gloves, check for leaks where the fuel injector connects to the fuel injection supply manifold. If leaks are detected, service as required.
14. Connect the fuel charging wiring to vehicle harness and start the engine. Check and adjust timing. Let engine idle for two minutes.
15. Using a clean paper towel and rubber gloves, check for leaks where the fuel injector is installed into the intake manifold and service as necessary.

Fuel Pressure Regulator**Tools Required:**

- Fuel Pressure Gauge T80L-9974-B

Removal

1. Verify fuel injection supply manifold assembly is depressurized by removing fuel tank cap and releasing pressure from fuel system at fuel pressure relief valve on fuel injection supply manifold assembly using Fuel Pressure Gauge T80L-9974-B or equivalent.
2. Remove vacuum line at fuel pressure regulator.
3. Remove two fuel rail-to-lower intake manifold retaining bolts. Carefully lift fuel injection supply manifold (regulator side only) off of fuel injector to gain access to fuel pressure regulator retaining screws.

4. Remove three Allen retaining screws from regulator housing and discard.
5. Remove fuel pressure regulator assembly, gasket and O-ring. Discard fuel pressure regulator gasket (9C977) and O-ring.

NOTE: If scraping is necessary, be careful not to damage fuel pressure regulator or fuel rail gasket surfaces.

Installation

CAUTION: Flexible fuel vehicle fuel pressure regulator components are strictly methanol compatible.

1. Lubricate new fuel pressure regulator O-ring with clean engine oil.
2. Ensure gasket surfaces of fuel pressure regulator and fuel injection supply manifold are clean.
3. Install new O-ring and new gasket on regulator.
4. Using new Allen head retaining screws, install fuel pressure regulator on fuel injection supply manifold. Tighten three retaining screws to 3.75 N·m (34 lb-in).
5. Carefully install regulator side of fuel injection supply manifold to fuel injectors. If fuel injectors were completely disengaged from fuel rail cup(s), lubricate injector O-rings with clean engine oil prior to inserting in fuel injection supply manifold cups. Push regulator side of fuel rail down on fuel injectors and tighten retaining bolts to 10 N·m (7 lb-ft) while holding down on fuel injection supply manifold.

Fuel Sensor**Tools Required:**

- Fuel Line Disconnect Tool T90T-9550-C

REMOVAL AND INSTALLATION (Continued)

Flexible Fuel Vehicles

The fuel sensor is designed to measure the amount of fuel methanol in the fuel mixture. The sensor sends a variable signal to the PCM through the wiring harness. The PCM adjusts outputs to the engine to provide optimum driveability based on the signal received. For diagnosis refer to the 1993 Powertrain Control/Emission Diagnosis manual⁴.

WARNING: DO NOT MODIFY THE FUEL SYSTEM CONFIGURATION OR COMPONENTS, OR REPLACE COMPONENTS WITH PARTS NOT SPECIALLY DESIGNED FOR USE WITH FUEL METHANOL. FORD MOTOR COMPANY HAS SPECIALLY-DESIGNED THE MATERIALS, COMPONENTS AND SYSTEM CONFIGURATION FOR METHANOL-FUELED VEHICLES AND EACH PARTICULAR SYSTEM IS PRECISELY CALIBRATED FOR EFFICIENT OPERATION. THE USE OF DIFFERENT PARTS OR MATERIALS COULD PRODUCE AN UNTESTED CONFIGURATION THAT COULD RESULT IN FIRE, PERSONAL INJURY, OR COULD CAUSE ENGINE DAMAGE.

Removal and Installation

1. Disconnect negative battery terminal from battery.
2. Relieve fuel system pressure. Refer to Section 10-01 for fuel system pressure relief procedures.
3. Disconnect fuel sensor (9C044) electrical connector.
4. Raise vehicle on hoist. Refer to Section 00-02A.
5. Remove RH front tire and wheel assembly. Refer to Section 04-04.
6. Remove fuel line retaining clip and fuel line from fuel mixer (9S301) at inlet hose, using Fuel Line Disconnect Tool T90T-9550-C.

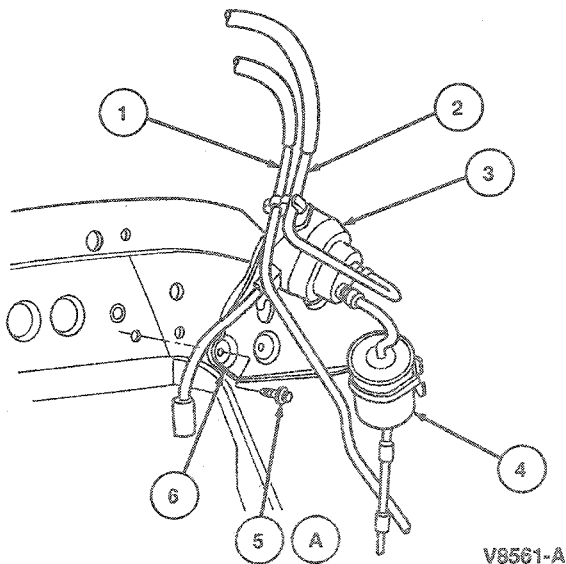

⁴ Can be purchased as a separate item.

Item	Part Number	Description
1	9J279	Fuel Return Line
2	9J285	Fuel Supply Line
3	9C044	Fuel Sensor Assy
4	9S301	Fuel Mixer Assy
5A	W611081-S56	Screw (2 Req'd)
6	9D319	Fuel Sensor Bracket
A		Tighten to 8-11.5 N·m (6-8 Lb·ft)

WARNING: COVER VALVE WITH SHOP CLOTH TO PREVENT ACCIDENTAL FUEL SPRAY INTO EYES.

7. Disconnect fuel sensor outlet hose using Fuel Line Disconnect Tool T90T-9550-C.
8. Remove fuel sensor bracket to frame rail retaining bolts and fuel sensor / mixer and bracket assembly from vehicle.
9. Loosen fuel mixer retainer clamp and disconnect fuel mixer outlet tube from fuel sensor using Fuel Line Disconnect Tool T90T-9550-C.
10. Remove fuel sensor retaining bolts and fuel sensor from bracket.
11. To install, reverse Removal procedures. Tighten fuel sensor retainer-to-bracket bolts to 3-4 N·m (27-34 lb-in). Tighten mixer retaining clamp to 5.8-9.3 N·m (51-82 lb-in). Tighten fuel sensor / mixer and bracket-to-frame fasteners to 8-11.5 N·m (6-8 lb-ft). Tighten the wheel lug nuts to 115-142 N·m (85-105 lb-ft).

Fuel Injection Wiring Harness

Removal

NOTE: Ensure ignition switch is in OFF position and fuel system is depressurized.

1. Remove throttle body as outlined.
2. Disconnect electrical connectors from fuel injectors.
3. Disconnect connectors from main wiring harness and throttle position sensor, intake air temperature (IAT) sensor and idle air control (IAC) valve.
4. Remove fuel charging wiring assembly.

Installation

1. Position fuel charging wiring along side fuel injectors.

CAUTION: Check distance between throttle body and rocker arm cover fuel charging wiring clearance at rocker arm cover valley on FF vehicles.

2. Snap electrical connectors into position on fuel injectors.
3. Install throttle body as outlined.

REMOVAL AND INSTALLATION (Continued)

4. Verify that all electrical connectors are firmly seated.
5. Use data link connector (DLC) and procedure to check for sensor function.

CLEANING AND INSPECTION

NOTE: The throttle body for this vehicle is a sludge resistant design and should not be cleaned.

Idle Air Control (IAC) Valve

CAUTION: Do not use the cleaning procedure on idle air control (IAC) valves, as valve damage may occur.

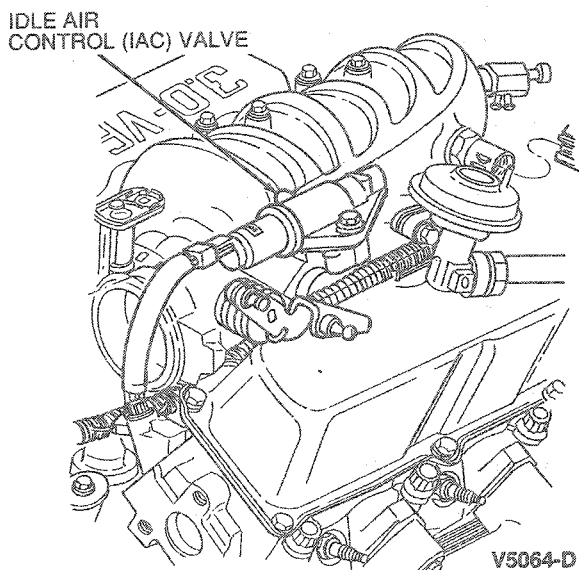

Air Cleaner

NOTE: If air cleaner cover assembly requires replacement, specify 3.0L or 3.0L flexible fuel (FF) vehicle.

Refer to Section 00-03 for the recommended air cleaner assembly maintenance mileage interval. **Cleaning the air cleaner or crankcase ventilation filter elements is not recommended.** They should be replaced at the specified mileage intervals. Clean the air cleaner body and the cover with a solvent or compressed air. Wipe the air cleaner body and cover dry if a solvent is used. Inspect the air cleaner body and cover for distortion or damage at the gasket mating surfaces. Replace cover or body if they are damaged beyond service. Hold filter in front of a light and carefully inspect it for any splits or cracks. If filter is split or cracked, replace it.

ADJUSTMENTS

Refer to the Powertrain Control Emissions / Diagnosis Manual⁵ for adjustment procedures.

SPECIFICATIONS

TORQUE SPECIFICATIONS

Description	N-m	Lb-In
Air Supply Tube Clamps	4	36
Throttle Body (TB) to Lower Intake Manifold Bolts	20-30	15-22 (Lb-Ft)
Idle Air Control Valve to Throttle Body	9.5	84
Throttle Position Sensor to Throttle Body	1.5	14
Fuel Pressure Relief (Schrader) Valve	7.75	66
Fuel Pressure Relief Valve Cap	0.6	5.5
Fuel Injection Supply Rail Assembly to Lower Intake Manifold	10	7 (Lb-Ft)
Fuel Pressure Regulator to Fuel Injection Supply Rail	3.75	34
Generator Brace to Throttle Body and Generator Bracket	16	12 (Lb-Ft)
EGR Tube to EGR Valve	50	37 (Lb-Ft)
Idle Air Control Valve Shield	1.4	13
Distributor Hold-Down Clamp	24	18 (Lb-Ft)
Throttle Bracket to Throttle Body	17	13 (Lb-Ft)
ESR Valve-to-Throttle Body	25	19 (Lb-Ft)
Vacuum Distributor Tree-to-Throttle Body	8-13	6-9 (Lb-Ft)
CSI Retainer Bolts	8-11	70-97
CSI Spray Bar Plug to Throttle Body	10-15	7-11 (Lb-Ft)
Fuel Sensor to Bracket Bolts	3-4	27-34
Fuel Sensor Bracket to Frame Bolts	8-11.5	6-8 (Lb-Ft)
Fuel Mixer Retainer Clamp	5.8-9.3	51-82

⁵ Can be purchased as a separate item.

SPECIAL SERVICE TOOLS

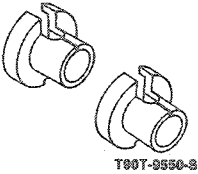
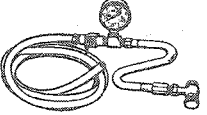
Tool Number / Description	Illustration
T90T-9550-C Fuel Line Disconnect Tool	 T90T-9550-C
T80L-9974-B Fuel Pressure Gauge	 T80L-9974-B
Tool Number	Description
D87L-9280-A	Spring Lock Coupling Disconnect Tool (3/8 inch)
D87L-9280-B	Spring Lock Coupling Disconnect Tool (1/2 inch)
ROTUNDA EQUIPMENT	
Model	Description
113-00001	Injector Tester/Cleaner

PARTS CROSS-REFERENCE

Base Part #	Part Name	Old Part Name
9424	Intake Manifold	
9A758	Throttle Cable	
9B989	Throttle Position Sensor	Throttle Potentiometer
9C968	Fuel Pressure Regulator	
9C977	Fuel Pressure Regulator Gasket	
9D475	EGR Valve	
9D930	Fuel Charging Wiring	
9E926	Throttle Body	
9F593	Fuel Injector	
9F715	Idle Air Control Valve	Throttle Air Bypass Valve
9F792	Fuel Injection Supply Manifold	
9H321	Fuel Pressure Relief Valve	
9H323	Fuel Pressure Relief Valve Cap	
9H486	Intake Manifold Upper Gasket	