

# FRAME AND MOUNTING

## GROUP 02 (6000)

SECTION TITLE	PAGE	SECTION TITLE	PAGE
ENGINE AND TRANSAXLE MOUNTING .....	02-03-1	SUBFRAME .....	02-01-1

## SECTION 02-01 Subframe

SUBJECT	PAGE	SUBJECT	PAGE
REMOVAL AND INSTALLATION		SPECIFICATIONS .....	02-01-3
Subframe, Front .....	02-01-1	VEHICLE APPLICATION .....	02-01-1
SPECIAL SERVICE TOOLS .....	02-01-3		

### VEHICLE APPLICATION

Taurus / Sable.

### REMOVAL AND INSTALLATION

#### Subframe, Front

##### Tools Required:

- Three Bar Engine Support D88L-6000-A

##### Removal

1. Disconnect battery ground cable.
2. Install engine lift eyes.
3. Install Three Bar Engine Support D88L-6000-A or equivalent to existing engine lifting eyes.
4. Raise vehicle on hoist with vehicle resting on four contact points. Refer to Section 00-02.
5. Remove front tires and wheels. Refer to Section 04-04.
6. Support steering gear with wire from the tie rod end to coil spring to hold steering gear in position. Secure housing of gear to suitable support to hold it in position.
7. Disconnect exhaust system at flex coupling and drop down.
8. Disconnect lower control arm at pinch bolts to ball joints.
9. Remove two nuts that attach steering gear to No. 2 crossmember.
10. Remove retaining nuts from RH front engine mount and RH rear engine mount to subframe.
11. Remove stabilizer bar link attachment to stabilizer bar.
12. Remove LH transaxle mount insulator at through bolts to subframe.
13. Support subframe with adjustable jacks at subframe body mount location points.
14. Remove four body mount retaining bolts.
15. With an assistant, lower adjustable jacks and allow subframe to lower. Rotate front of subframe down and pick up rear of subframe off of exhaust pipe. Work subframe rearward until it can be lowered down past exhaust pipe.
16. Place subframe on floor or bench and transfer suspension components to the new subframe.

## REMOVAL AND INSTALLATION (Continued)

### Installation

- On 3.0L SHO engine equipped vehicles with manual transaxle, install four body mount retaining nuts to each mount. Tighten to 8-11 N·m (6-8 lb-ft). On vehicles equipped with 3.0L, 3.2L SHO and 3.8L engines install front body mounts to RH and LH subframe. Install four nuts to each mount and tighten to 8-11 N·m (6-8 lb-ft).  
**NOTE: DO NOT TIGHTEN AT THIS TIME.**
- With an assistant, align subframe to body. Install two rear subframe-to-body rubber mounts on 3.0L, 3.2L SHO and 3.8L engine equipped vehicles. Install four bolts into mounts.

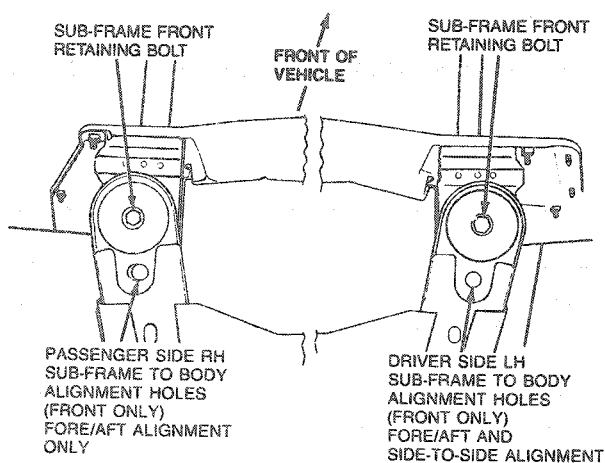

- Install a 19mm (3/4 inch) outside diameter pipe or similar tool into front LH subframe and body alignment holes. After aligning the holes, slightly tighten the LH front body mount bolt.
- Repeat Step 2 on front RH alignment holes.
- Check front LH alignment holes with tool.
- After subframe alignment is complete, tighten four subframe-to-body bolts to 75-102 N·m (55-75 lb-ft).

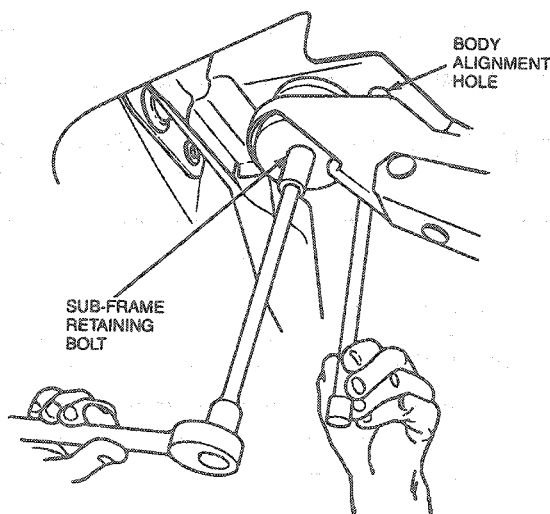

F4753-B

- Install LH transaxle mount insulator at through bolts to subframe. Tighten to 81-116 N·m (60-85 lb-ft).
- Install stabilizer bar link attachment to stabilizer bar. Tighten to 47-65 N·m (35-47 lb-ft).
- Install two retaining nuts that secure the steering gear to the No. 2 crossmember. Tighten to 115-135 N·m (85-99 lb-ft).
- Remove wire supporting steering gear from tie rod end to coil spring.
- Install retaining nuts that secure the RH front engine mount and the RH rear engine mount to subframe. Tighten to 75-102 N·m (55-75 lb-ft).
- Connect lower control arm at pinch bolts to ball joints.
- Connect exhaust system at flex coupling and position in place.
- Install tires and wheels. Refer to Section 04-04.
- Lower hoist.

- Remove Three Bar Engine Support D88L-6000-A or equivalent and engine lifting eyes.
- Check front end alignment. Adjust if necessary. Refer to Section 04-00.

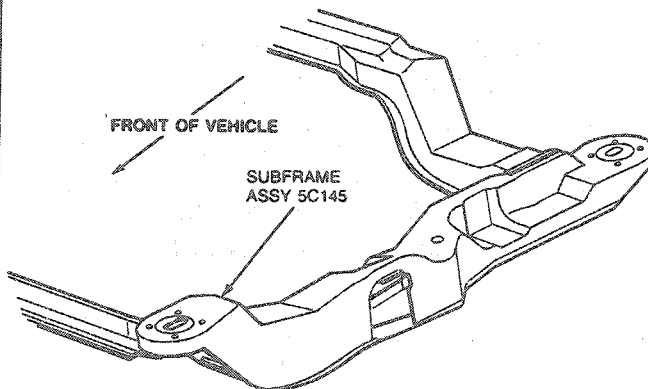

LH SIDE SHOWN RH SIDE SIMILAR

F3887-A

## SPECIFICATIONS

TORQUE SPECIFICATIONS		
Description	N-m	Lb-Ft
Body Mount Retaining Bolts	75-102	55-75
Body Mount to Subframe Bolts	8-11	6-8
Transaxle Mount-to-Subframe Bolts (LH)	81-116	60-85
Front Engine Mount-to-Subframe Bolts (RH)	75-102	55-75
Rear Engine Mount-to-Subframe Bolts (RH)	75-102	55-70
Stabilizer Link-to-Stabilizer Bar Nuts	47-65	35-47
Gear-to-Crossmember Nuts	115-135	85-99

## SPECIAL SERVICE TOOLS

Tool Number	Description
D88L-6000-A	Three Bar Engine Support

# SECTION 02-03 Engine and Transaxle Mounting

SUBJECT	PAGE	SUBJECT	PAGE
<b>REMOVAL AND INSTALLATION</b>		<b>SPECIAL SERVICE TOOLS</b> .....	02-03-9
Engine Mounts, 3.0L EFI Engine .....	02-03-4	<b>SPECIFICATIONS</b> .....	02-03-8
Engine Mounts, 3.0L SHO Engine .....	02-03-1	<b>VEHICLE APPLICATION</b> .....	02-03-1
Engine Mounts, 3.8L EFI Engine .....	02-03-6		

## VEHICLE APPLICATION

Taurus/Sable.

## REMOVAL AND INSTALLATION

### Engine Mounts, 3.0L SHO Engine

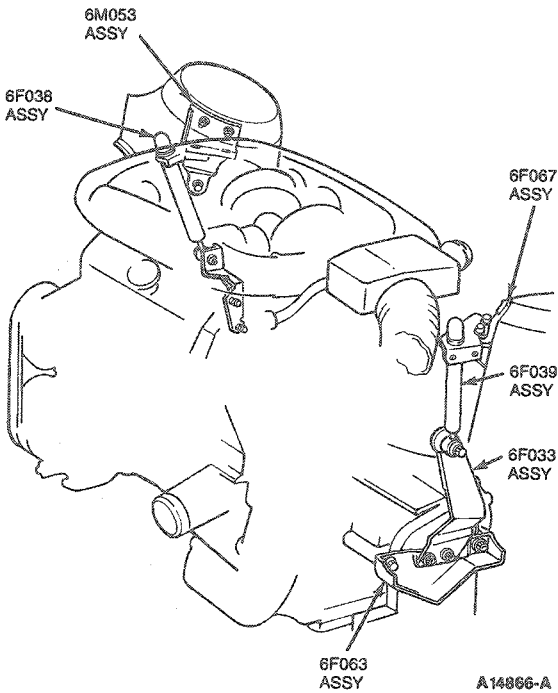

2. Raise vehicle on hoist. Refer to Section 00-02.
3. Place jack and wood block in suitable place under engine.
4. Remove roll damper to engine mount retaining bolts and remove roll damper.
5. Raise engine with jack (enough to unload insulator).

### Insulator, RH Front, No. 2 and/or RH Rear, No. 3

#### Removal

1. Remove lower damper retaining bolt from RH side of engine.

## REMOVAL AND INSTALLATION (Continued)

6. Remove two through bolts and remove insulator from engine bracket.

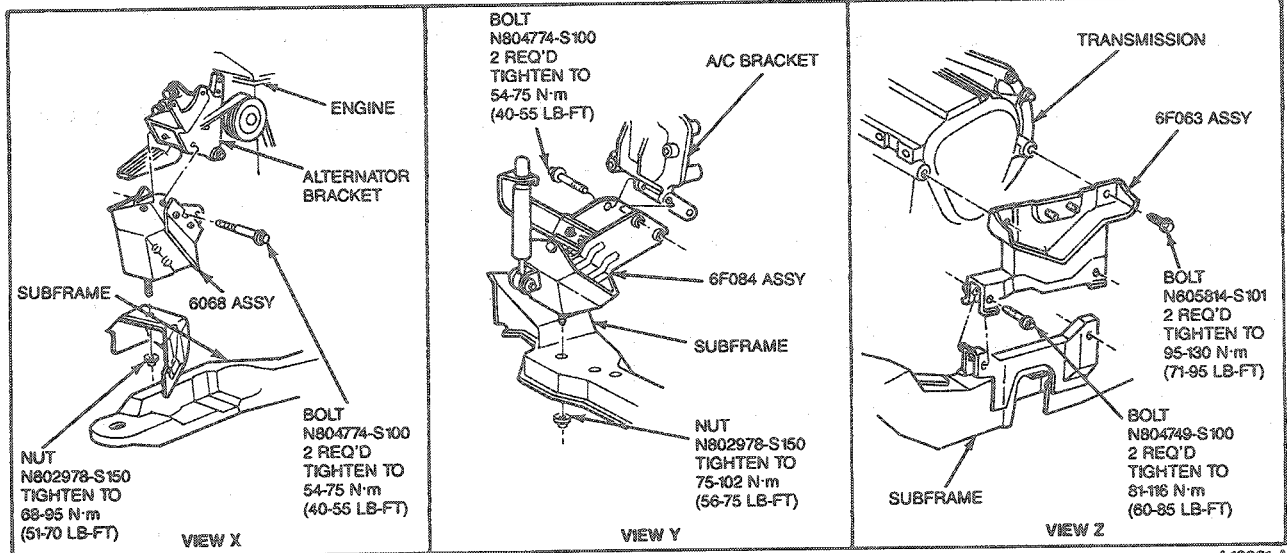
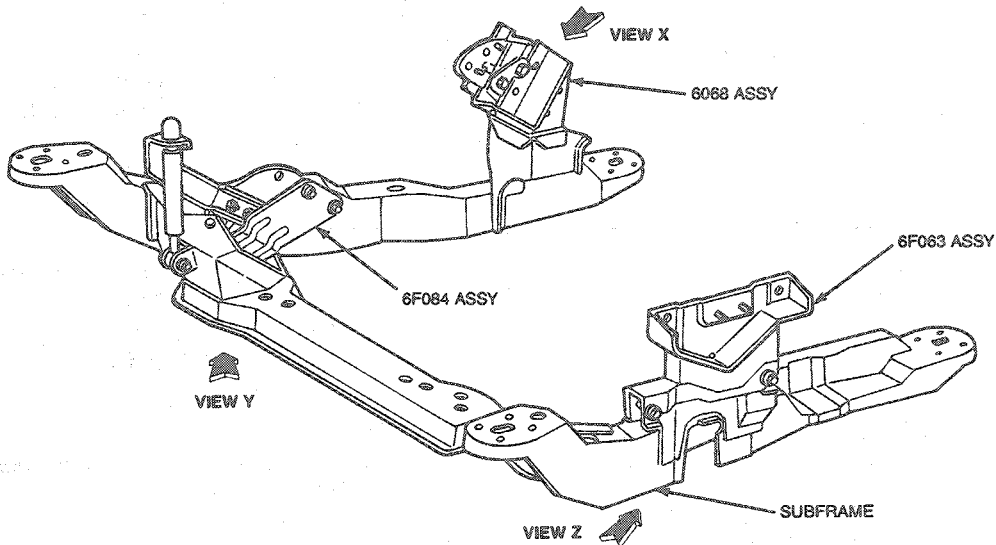

A12851-A

## Installation

1. Install insulator-to-engine support bracket with two through bolts. Tighten through bolts to 54-75 N·m (40-55 lb-ft). Refer to illustration under Removal, Step 6.
2. Lower engine down onto frame.
3. Install nuts retaining RH front and RH rear insulators to frame. Tighten nuts to 75-102 N·m (55-75 lb-ft). Install roll damper. Tighten bolts to 54-75 N·m (40-55 lb-ft).
4. Remove jack and lower vehicle.
5. Install bolt retaining RH engine damper to engine. Tighten bolt to 54-75 N·m (40-55 lb-ft).

## Insulator, LH and Support Assembly No. 1A

## Removal

1. Remove bolt retaining roll damper to lower damper bracket and place damper shaft out of the way.
2. Remove backup lamp switch.
3. Remove energy management bracket.
4. Raise vehicle on hoist. Refer to Section 00-02. Position jackstands under vehicle body allowing subframe to hang.
5. Remove LH tire and wheel.
6. Place jack and wood block in suitable place under transaxle and support transaxle.

## REMOVAL AND INSTALLATION (Continued)

7. Remove bolts retaining lower damper bracket to engine mount.
8. Remove bolts retaining insulator to transaxle and subframe.
9. Raise transaxle with jack (enough to unload insulator).
10. Remove insulator and lower damper bracket.

LH, No. 1A

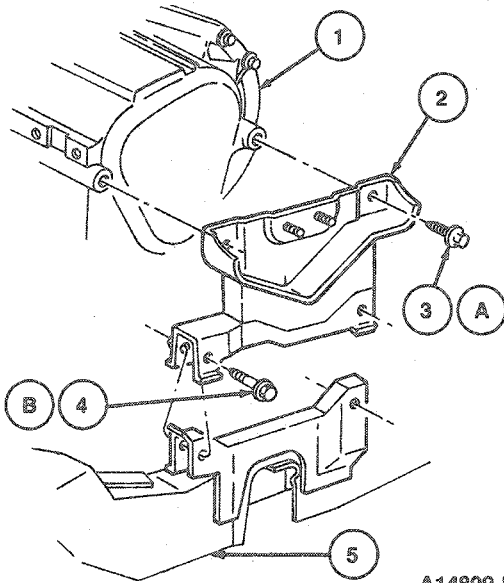

A14899-B

Item	Part Number	Description
1	—	Transaxle
2	6F063	Bracket Assy

(Continued)

Item	Part Number	Description
3A	N6058 14-S 101	Bolt (2 Req'd)
4B	N804749-S 100	Bolt (2 Req'd)
5	—	Subframe
A		Tighten to 95-130 N·m (71-95 Lb·Ft)
B		Tighten to 81-116 N·m (60-85 Lb·Ft)

## Installation

1. Loosely install insulator and damper bracket to transaxle and subframe.
2. Install damper bracket to insulator. Tighten bolts to 54-75 N·m (40-55 lb-ft).
3. Install insulator to transaxle. Tighten bolts to 95-130 N·m (71-95 lb-ft).
4. Install insulator to frame. Tighten bolts to 81-116 N·m (60-85 lb-ft).
5. Remove jack and jackstands.
6. Install LH tire and wheel. Tighten wheel lug nuts to 115-142 N·m (85-105 lb-ft).
7. Lower vehicle.
8. Install damper to damper bracket. Tighten bolt to 54-75 N·m (40-55 lb-ft).
9. Install backup lamp switch.
10. Install energy management bracket.

## REMOVAL AND INSTALLATION (Continued)

## Engine Mounts, 3.0L EFI Engine

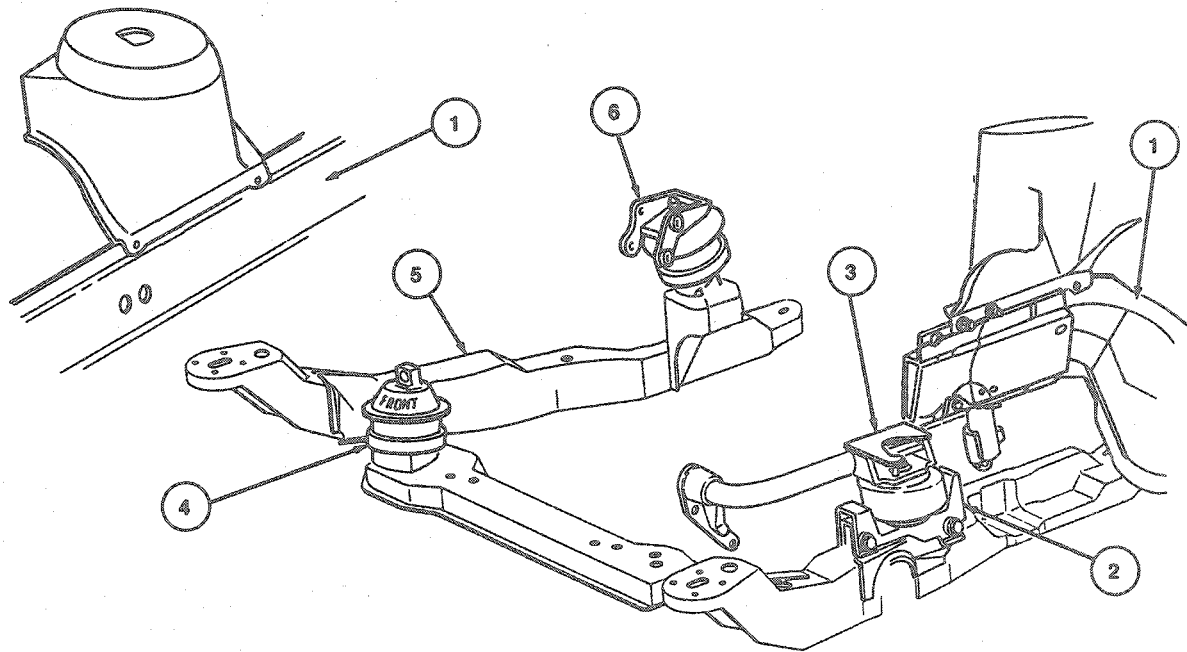

A9703-F

Item	Part Number	Description
1	—	Side Member
2	6F063	Insulator No. 1A
3	6F065	Support Assy
4	6038	No. 2 Insulator
5	—	Frame
6	6068	No. 3 Insulator

## Insulator, RH Front, No. 2 and/or RH Rear, No. 3

## Removal

1. Raise vehicle on hoist. Refer to Section 00-02.
2. Place jack and wood block in suitable place under engine block.
3. Remove nuts retaining RH front and RH rear insulators to frame.

4. Raise engine with jack (enough to unload insulator).
5. Remove two bolts from No. 3 insulator and one bolt from No. 2 insulator and remove insulator from engine bracket.

REMOVAL AND INSTALLATION (Continued)

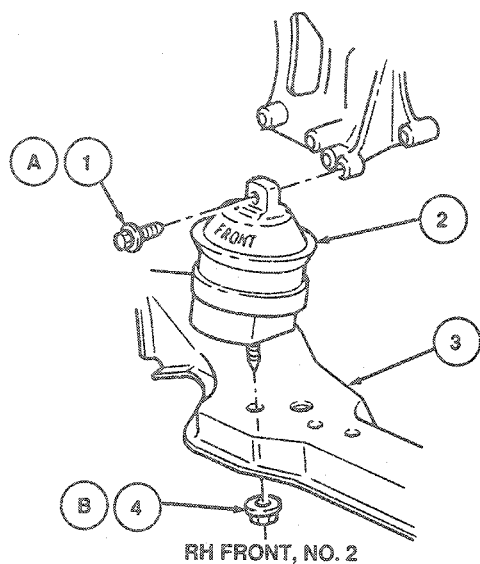

RH FRONT, NO. 2

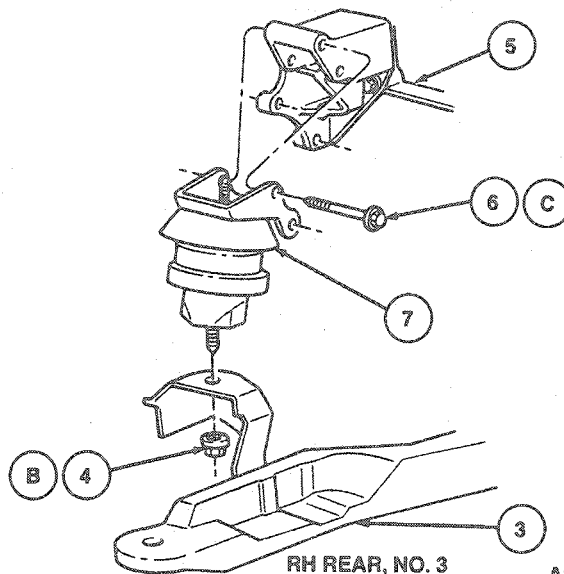

RH REAR, NO. 3

A14900-C

Item	Part Number	Description
1A	N605933-S101	Bolt
2	6038	Insulator
3	—	Subframe
4B	N802978-S150	Nut
5	—	Engine
6C	N804774-S100	Bolt (2 Req'd)

Item	Part Number	Description
7	6D089	Insulator
A		Tighten to 164-173 N-m (120-127 Lb-Ft)
B		Tighten to 75-102 N-m (56-75 Lb-Ft)
C		Tighten to 54-75 N-m (40-55 Lb-Ft)

(Continued)

Installation

1. Attach insulator-to-engine support bracket with two bolts on No. 3 insulator. Tighten bolts to 54-75 N-m (40-55 lb-ft). Attach bolt to No. 2 insulator. Tighten bolt to 164-173 N-m (120-127 lb-ft). Refer to illustration under Removal, Step 5.
2. Lower engine down onto frame.
3. Install nuts retaining RH front and RH rear insulators to frame. Tighten nuts to 75-102 N-m (56-75 lb-ft).
4. Remove jack and lower vehicle.

Insulator, LH and Support Assembly No. 1A

Removal

1. Raise vehicle on hoist. Refer to Section 00-02.
2. Remove LH tire and wheel.
3. Place jack and wood block in suitable place under transaxle and support transaxle.
4. Remove two nuts retaining insulator to support assembly.
5. Remove two through bolts retaining insulator to frame.

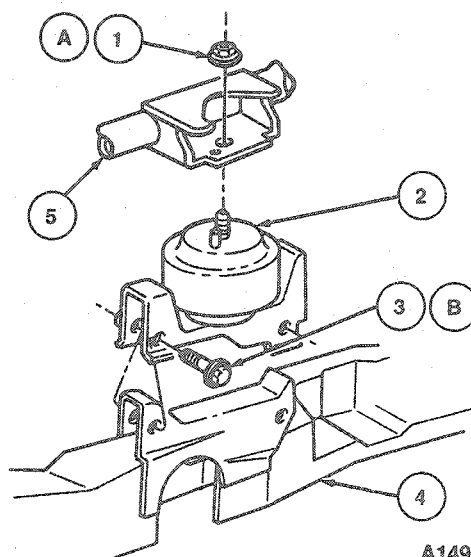

A14926-C



## REMOVAL AND INSTALLATION (Continued)

Item	Part Number	Description
1A	N800937-S102	Nut
2	6F063(LH)	Engine Mount Assy
3B	N804749-S100	Bolt (2 Req'd)
4	—	Frame
5	6F065	Support Assy
A		Tighten to 74-102 N·m (55-75 Lb-Ft)
B		Tighten to 81-116 N·m (60-85 Lb-Ft)

6. Raise transaxle with jack (enough to unload insulator).
7. Remove bolts retaining support assembly to transaxle.
8. Remove transaxle support assembly by rotating support assembly counterclockwise to disengage upper stud on mount.
9. Remove mount.

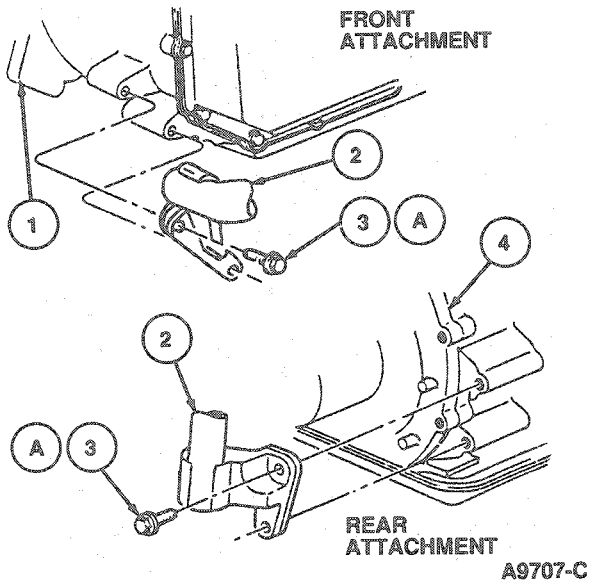

Item	Part Number	Description
1	—	Transaxle
2	6F065	Support Assy
3A	N605922-S102	Bolt (2 Req'd)
4	07002	Transaxle
A		Tighten to 54-75 N·m (40-55 Lb-Ft)

**Installation**

1. Loosely install mount.
2. Attach support assembly to transaxle. Tighten bolts to 54-75 N·m (40-55 lb-ft). Refer to illustration under Removal, Step 8.
3. Attach insulator to frame with two through bolts. Tighten bolts to 81-116 N·m (60-85 lb-ft).

4. Lower transaxle (enough to load insulator).
5. Attach insulator to support assembly with two nuts. Tighten nuts to 74-102 N·m (55-75 lb-ft). Refer to illustration under Removal, Step 5.
6. Attach damper shaft to support assembly using a new flag nut. Tighten bolt to 28-41 N·m (21-30 lb-ft).
7. Remove jack.
8. Install LH tire and wheel. Tighten wheel lug nuts to 115-142 N·m (85-105 lb-ft).
9. Lower vehicle.

**Engine Mounts, 3.8L EFI Engine****Tools Required:**

- Three Bar Engine Support D88L-6000-A
- Hydraulic Engine Mount, RH Front

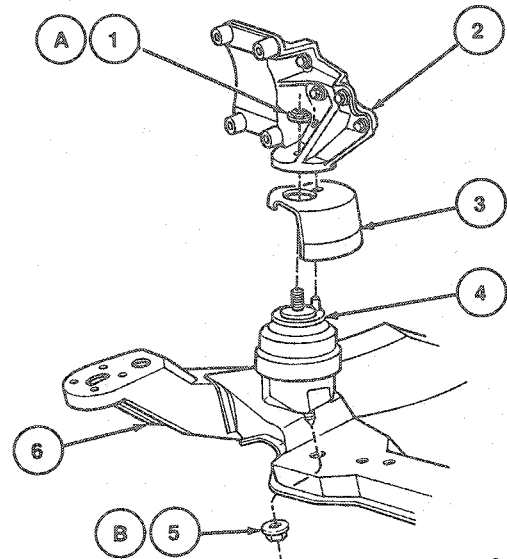

Item	Part Number	Description
1A	N800937-S102	Nut
2	—	A/C Bracket
3	6C038	Shield
4	6038	Insulator Assy (Color Code Yellow-Non-Police; Color Code Blue-Police)
5B	N802978-S150	Nut
6	—	Frame
A		Tighten to 54-75 N·m (40-55 Lb-Ft)
B		Tighten to 75-102 N·m (55-75 Lb-Ft)

## REMOVAL AND INSTALLATION (Continued)

## Removal

1. Remove mount upper retaining nut through engine compartment between A/C compressor and compressor bracket using a long extension and an 18mm swivel socket.
2. Install Three Bar Engine Support D88L-6000-A or equivalent.
3. Raise vehicle on hoist. Refer to Section 00-02.
4. Loosen RH rear mount lower retaining nut.
5. Remove RH front mount lower retaining nut.
6. Lower vehicle.
7. Raise engine approximately 25mm (1 inch) using engine support tool.
8. Raise vehicle.
9. Remove engine mount.

## Installation

1. Install engine mount.
  2. Lower vehicle.
  3. Lower engine using engine support tool.
  4. Raise vehicle.
  5. Install RH front mount lower retaining nut and tighten to 75-102 N·m (55-75 lb-ft).
- NOTE: During installation of mount, hold lower can to prevent twisting when lower nut is tightened.
6. Tighten RH rear lower mount retaining nut to 75-102 N·m (55-75 lb-ft).
  7. Lower vehicle.
  8. Remove engine support tool.
  9. Install mount upper retaining nut through engine compartment between A/C compressor and compressor bracket using a long extension and an 18mm swivel socket.
  10. Tighten mount upper retaining nut to 54-75 N·m (40-55 lb-ft).

## Transaxle Hydramount Assembly, LH

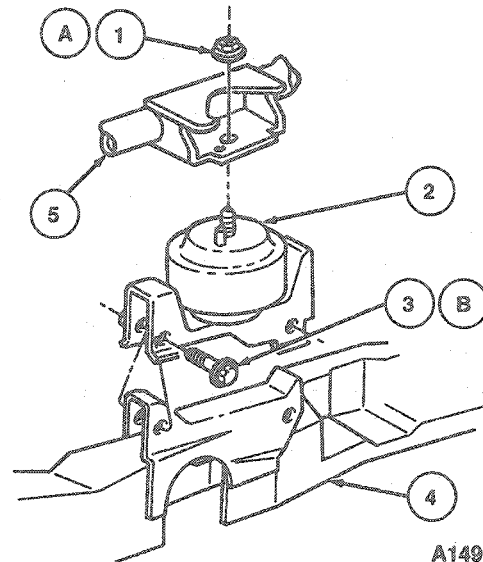

Item	Part Number	Description
1A	N800937-S102	Nut
2	6F063(LH)	Engine Mount Assy
3B	N804749-S100	Bolt (2 Req'd)
4	—	Frame
5	6F065	Support Assy
A		Tighten to 74-102 N·m (55-75 Lb-Ft)
B		Tighten to 81-116 N·m (60-85 Lb-Ft)

## Removal

1. Raise vehicle on hoist. Refer to Section 00-02.
2. Remove tire and wheel.
3. Place a jack and wood block in a suitable place under the transaxle and support the transaxle.
4. Remove the nut retaining the transaxle mount to the support assembly.
5. Remove two through bolts retaining the transaxle mount to the frame.
6. Raise the transaxle with the jack (enough to unload mount).
7. Remove the bolts retaining the support assembly to the transaxle.
8. Remove transaxle support assembly by rotating support assembly counterclockwise to disengage upper stud on mount.
9. Remove mount.

## Installation

1. Loosely install mount.
2. Attach support assembly to the transaxle and tighten to 54-75 N·m (40-55 lb-ft).

## REMOVAL AND INSTALLATION (Continued)

3. Attach insulator to frame with two through bolts and tighten to 81-116 N·m (60-85 lb-ft).
4. Lower the transaxle (enough to load the mount).
5. Install transaxle mount retaining nut insulator to support assembly and tighten to 74-102 N·m (55-75 lb-ft).
6. Remove jack.
7. Install tire and wheel. Tighten wheel lug nuts to 115-142 N·m (85-105 lb-ft).
8. Lower vehicle.

## Engine Mount, RH Rear

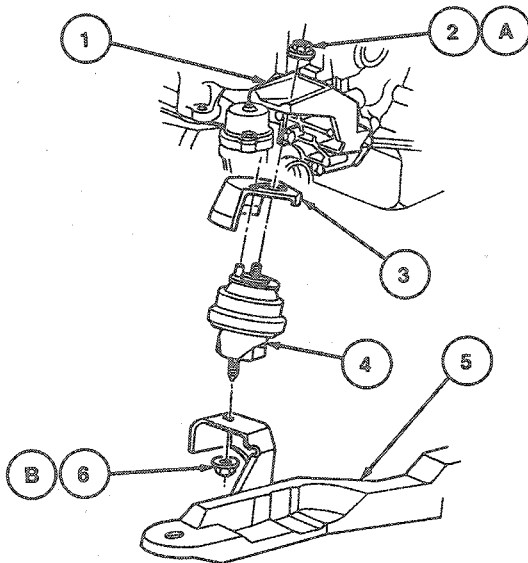

A14883-B

Item	Part Number	Description
1	—	Transaxle
2A	N800937-S102	Nut
3	6C038	Shield
4	6068	Insulator Assy (Color Code Green-Non-Police; Color Code Blue-Police)
5	—	Frame
6B	N802978-S150	Nut
A		Tighten to 54-75 N·m (40-55 Lb-Ft)
B		Tighten to 75-102 N·m (55-75 Lb-Ft)

## Removal

1. Raise vehicle on hoist. Refer to Section 00-02.
2. Remove the nuts retaining the RH front and RH rear engine mounts to the frame.
3. Lower vehicle.
4. Use Three Bar Engine Support D88L-6000-A or equivalent to support engine. Install J-hook on the alternator bracket. Raise the engine about 25mm (1 inch).

5. Loosen retaining nut on the LH rear (No. 3) mount and heat shield assembly.
6. Raise vehicle on hoist.
7. Remove No. 3 insulator retaining nut. Remove No. 3 insulator and heat shield assembly.

## Installation

1. Install mount and position No. 3 mount and heat shield assembly upper stud and anti-rotation pin to the transaxle support bracket. Hand start lower retaining nut.
2. Lower vehicle.
3. Tighten top retaining nut on the No. 3 insulator (LH rear). Tighten to 54-75 N·m (40-55 lb-ft).
4. Lower engine and remove the Three Bar Engine Support.
5. Raise vehicle.
6. Tighten retaining nuts on RH front and RH rear engine mounts. Tighten to 75-102 N·m (55-75 lb-ft).
7. Lower vehicle.

## SPECIFICATIONS

## TORQUE SPECIFICATIONS

Description	N·m	Lb-Ft
Insulator-to-Engine Support Bracket Bolts	54-75	40-55
RH Front RH Rear Insulator-to-Frame Nuts	75-102	55-75
Support Assembly-to-Transaxle Bolts (4 Req'd)	54-75	40-55
RH Front Insulator-to-Frame Nuts	75-102	55-75
RH Rear Insulator-to-Frame Nuts	75-102	55-75
Engine Damper-to-Subframe Bracket Bolt	54-75	40-55
RH Engine Damper-to-Engine Bolts (3.0L SHO Engine)	54-75	40-55
Damper-to-Damper Bracket Bolts	54-75	40-55
Insulator-to-Transaxle Bolts (3.0L SHO Engine)	127-172	94-127
Insulator-to-Frame Bolts (2 Req'd)	81-116	60-85
Wheel Lug Nuts	115-142	85-105
RH Front and RH Rear Insulator-to-Frame Nuts (3.0L SHO Engine)	54-75	40-55
Insulator-to-Support Assembly Nut	74-102	55-75
Insulator-to-Engine A/C Bracket Bolts	54-75	40-55
Damper Shaft-to-Support Assembly Bolt	28-41	21-30
Nut Retaining Mount-to-A/C Bracket Bolt	54-75	40-55
Retaining Nut-to-No. 3 Insulator LH Rear	54-75	40-55

**SPECIAL SERVICE TOOLS**

Tool Number	Description
D88L-6000-A	Three Bar Engine Support