

ADJUSTMENTS (Continued)

Arm and Blade Assembly, Rear

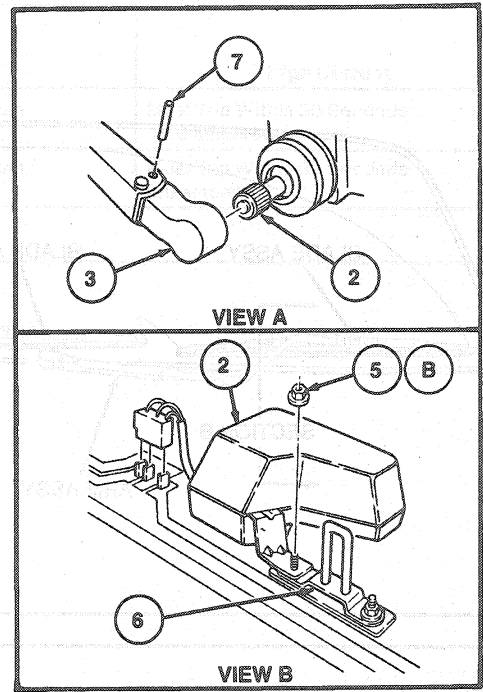
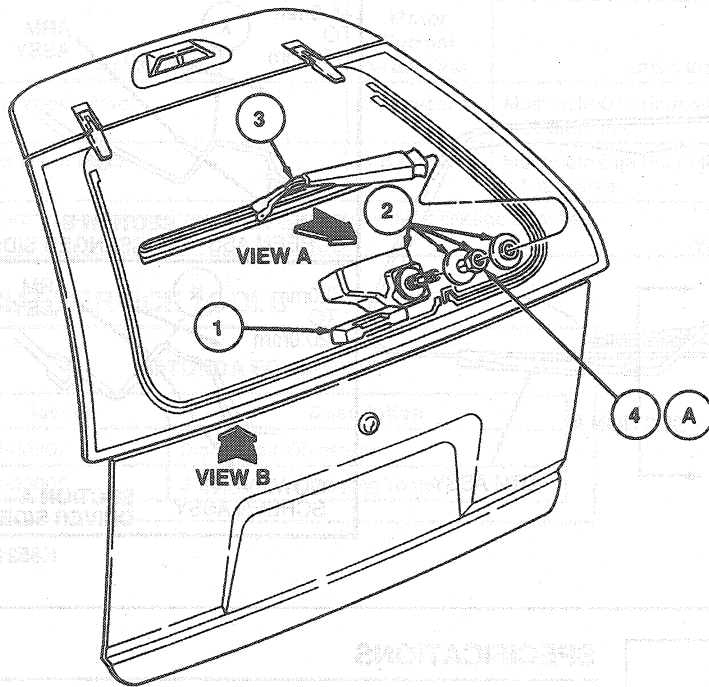

K8520-E

Item	Part Number	Description
1	44409	Back Window Handle
2	17C541	Rear Window Wiper Motor Assy
3	17C403	Rear Arm and Blade Assy
4A	17A475	Nut, Grommet and Washer Assy

(Continued)

Item	Part Number	Description
5B	—	Nut and Washer Assy
6	42148	Back Window Latch Striker Assy
7	—	1 / 16 Inch Diameter Roll Pin
A		Tighten to 15-20 N-m (11-14 Lb-Ft)
B		Tighten to 5-8 N-m (4-6 Lb-Ft)

Install the arm blade assemblies on the pivot shafts to Dimension X.

