

ADJUSTMENTS (Continued)

Arm and Blade Assembly, Front

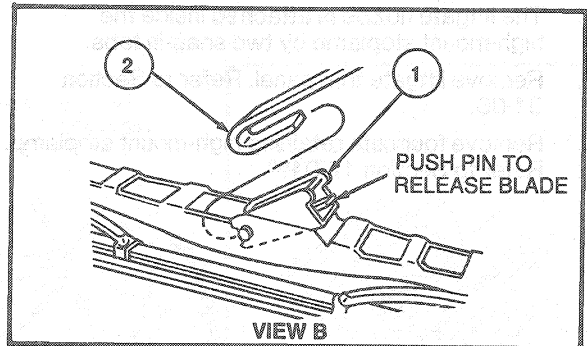
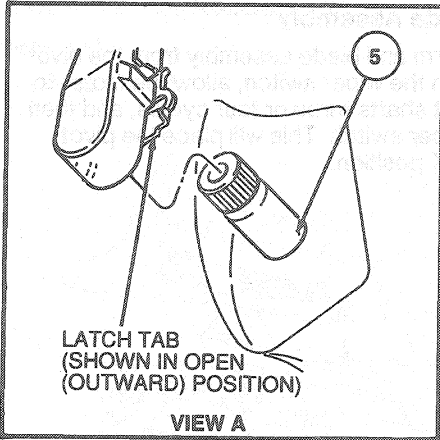
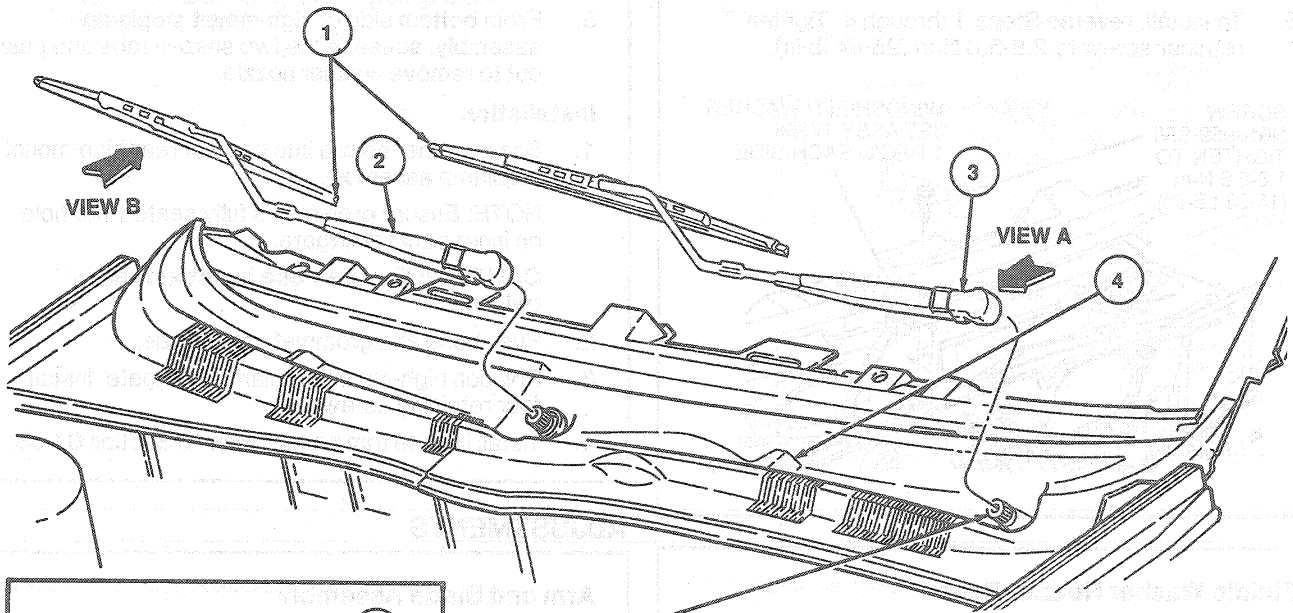

K8519-F

Item	Part Number	Description
1	17528	Blade Assy Windshield Wiper (2 Req'd)
2	17526 (RH)	Arm Assy
3	17527 (LH)	Arm Assy
4	17C549	Wiper Arm Stop
5	17566	Arm and Pivot Shaft Assy