

**BRAKE OPERATING SYSTEM 9-2**  
BASIC OPERATING PRINCIPLES 9-2  
DISC BRAKES 9-2  
DRUM BRAKES 9-2  
POWER BOOSTERS 9-3  
BRAKE LIGHT SWITCH 9-3  
REMOVAL & INSTALLATION 9-3  
MASTER CYLINDER 9-3  
REMOVAL & INSTALLATION 9-3  
BRAKE PRESSURE CONTROL VALVE 9-4  
REMOVAL & INSTALLATION 9-4  
METERING VALVE 9-4  
REMOVAL & INSTALLATION 9-4  
BLEEDING THE BRAKE SYSTEM 9-4  
**DISC BRAKES 9-5**  
BRAKE PADS 9-5  
REMOVAL & INSTALLATION 9-5  
INSPECTION 9-7  
BRAKE CALIPER 9-7  
REMOVAL & INSTALLATION 9-7  
BRAKE DISC (ROTOR) 9-8  
REMOVAL & INSTALLATION 9-8  
INSPECTION 9-9  
**DRUM BRAKES 9-10**  
BRAKE DRUMS 9-11  
REMOVAL & INSTALLATION 9-11  
INSPECTION 9-11  
BRAKE SHOES 9-11  
INSPECTION 9-11  
REMOVAL & INSTALLATION 9-11  
ADJUSTMENTS 9-14  
WHEEL CYLINDERS 9-14  
INSPECTION 9-14  
REMOVAL & INSTALLATION 9-14  
**PARKING BRAKE 9-15**  
BRAKE SHOES (PARKING) 9-15  
REMOVAL & INSTALLATION 9-15  
**ANTI-LOCK BRAKE SYSTEM 9-16**  
GENERAL INFORMATION 9-16  
SYSTEM COMPONENTS 9-16  
ABS MODULE 9-16  
REMOVAL & INSTALLATION 9-16  
HYDRAULIC CONTROL UNIT 9-17  
REMOVAL & INSTALLATION 9-17  
SPEED SENSORS 9-17  
REMOVAL & INSTALLATION 9-17  
BLEEDING THE ABS SYSTEM 9-19  
**COMPONENT LOCATIONS**  
REAR DRUM BRAKE  
COMPONENTS 9-10  
**SPECIFICATIONS CHART**  
BRAKE SPECIFICATIONS 9-20

# 9

## BRAKES

BRAKE OPERATING SYSTEM 9-2  
DISC BRAKES 9-5  
DRUM BRAKES 9-10  
PARKING BRAKE 9-15  
ANTI-LOCK BRAKE SYSTEM 9-16

## BRAKE OPERATING SYSTEM

## Basic Operating Principles

Hydraulic systems are used to actuate the brakes of all modern automobiles. The system transports the power required to force the frictional surfaces of the braking system together from the pedal to the individual brake units at each wheel. A hydraulic system is used for two reasons.

First, fluid under pressure can be carried to all parts of an automobile by small pipes and flexible hoses without taking up a significant amount of room or posing routing problems.

Second, a great mechanical advantage can be given to the brake pedal end of the system, and the foot pressure required to actuate the brakes can be reduced by making the surface area of the master cylinder pistons smaller than that of any of the pistons in the wheel cylinders or calipers.

The master cylinder consists of a fluid reservoir along with a double cylinder and piston assembly. Double type master cylinders are designed to separate the front and rear braking systems hydraulically in case of a leak. The master cylinder converts mechanical motion from the pedal into hydraulic pressure within the lines. This pressure is translated back into mechanical motion at the wheels by either the wheel cylinder (drum brakes) or the caliper (disc brakes).

Steel lines carry the brake fluid to a point on the vehicle's frame near each of the vehicle's wheels. The fluid is then carried to the calipers and wheel cylinders by flexible tubes in order to allow for suspension and steering movements.

In drum brake systems, each wheel cylinder contains two pistons, one at either end, which push outward in opposite directions and force the brake shoe into contact with the drum.

In disc brake systems, the cylinders are part of the calipers. At least one cylinder in each caliper is used to force the brake pads against the disc.

All pistons employ some type of seal, usually made of rubber, to minimize fluid leakage. A rubber dust boot seals the outer end of the cylinder against dust and dirt. The boot fits around the outer end of the piston on disc brake calipers, and around the brake actuating rod on wheel cylinders.

The hydraulic system operates as follows: When at rest, the entire system, from the piston(s) in the master cylinder to those in the wheel cylinders or calipers, is full of brake fluid. Upon application of the brake pedal, fluid trapped in front of the master cylinder piston(s) is forced through the lines to the wheel cylinders. Here, it forces the pistons outward, in the case of drum brakes, and inward toward the disc, in the case of disc brakes. The motion of the pistons is opposed by return springs mounted outside the cylinders in drum brakes, and by spring seals, in disc brakes.

Upon release of the brake pedal, a spring located inside the master cylinder immediately returns the master cylinder pistons to the normal position. The pistons contain check valves and the master cylinder has compensating ports drilled in it. These are uncovered as the pistons reach their normal position. The piston check valves allow fluid to flow toward the wheel cylinders or calipers as the pistons withdraw. Then, as the return springs force the

brake pads or shoes into the released position, the excess fluid reservoir through the compensating ports. It is during the time the pedal is in the released position that any fluid that has leaked out of the system will be replaced through the compensating ports.

Dual circuit master cylinders employ two pistons, located one behind the other, in the same cylinder. The primary piston is actuated directly by mechanical linkage from the brake pedal through the power booster. The secondary piston is actuated by fluid trapped between the two pistons. If a leak develops in front of the secondary piston, it moves forward until it bottoms against the front of the master cylinder, and the fluid trapped between the pistons will operate the rear brakes. If the rear brakes develop a leak, the primary piston will move forward until direct contact with the secondary piston takes place, and it will force the secondary piston to actuate the front brakes. In either case, the brake pedal moves farther when the brakes are applied, and less braking power is available.

All dual circuit systems use a switch to warn the driver when only half of the brake system is operational. This switch is usually located in a valve body which is mounted on the firewall or the frame below the master cylinder. A hydraulic piston receives pressure from both circuits, each circuit's pressure being applied to one end of the piston. When the pressures are in balance, the piston remains stationary. When one circuit has a leak, however, the greater pressure in that circuit during application of the brakes will push the piston to one side, closing the switch and activating the brake warning light.

In disc brake systems, this valve body also contains a metering valve and, in some cases, a proportioning valve. The metering valve keeps pressure from traveling to the disc brakes on the front wheels until the brake shoes on the rear wheels have contacted the drums, ensuring that the front brakes will never be used alone. The proportioning valve controls the pressure to the rear brakes to lessen the chance of rear wheel lock-up during very hard braking.

Warning lights may be tested by depressing the brake pedal and holding it while opening one of the wheel cylinder bleeder screws. If this does not cause the light to go on, substitute a new lamp, make continuity checks, and, finally, replace the switch as necessary.

The hydraulic system may be checked for leaks by applying pressure to the pedal gradually and steadily. If the pedal sinks very slowly to the floor, the system has a leak. This is not to be confused with a springy or spongy feel due to the compression of air within the lines. If the system leaks, there will be a gradual change in the position of the pedal with a constant pressure.

Check for leaks along all lines and at wheel cylinders. If no external leaks are apparent, the problem is inside the master cylinder.

## DISC BRAKES

Instead of the traditional expanding brakes that press outward against a circular drum, disc brake systems utilize a disc (rotor) with brake pads positioned on either side of it. An easily-seen analogy is

the hand brake arrangement on a bicycle. The pads squeeze onto the rim of the bike wheel, slowing its motion. Automobile disc brakes use the identical principle but apply the braking effort to a separate disc instead of the wheel.

The disc (rotor) is a casting, usually equipped with cooling fins between the two braking surfaces. This enables air to circulate between the braking surfaces making them less sensitive to heat buildup and more resistant to fade. Dirt and water do not drastically affect braking action since contaminants are thrown off by the centrifugal action of the rotor or scraped off by the pads. Also, the equal clamping action of the two brake pads tends to ensure uniform, straight line stops. Disc brakes are inherently self-adjusting. There are three general types of disc brake:

- A fixed caliper.
- A floating caliper.
- A sliding caliper.

The fixed caliper design uses two pistons mounted on either side of the rotor (in each side of the caliper). The caliper is mounted rigidly and does not move.

The sliding and floating designs are quite similar. In fact, these two types are often lumped together. In both designs, the pad on the inside of the rotor is moved into contact with the rotor by hydraulic force. The caliper, which is not held in a fixed position, moves slightly, bringing the outside pad into contact with the rotor. There are various methods of attaching floating calipers. Some pivot at the bottom or top, and some slide on mounting bolts. In any event, the end result is the same.

## DRUM BRAKES

Drum brakes employ two brake shoes mounted on a stationary backing plate. These shoes are positioned inside a circular drum which rotates with the wheel assembly. The shoes are held in place by springs. This allows them to slide toward the drums (when they are applied) while keeping the linings and drums in alignment. The shoes are actuated by a wheel cylinder which is mounted at the top of the backing plate. When the brakes are applied, hydraulic pressure forces the wheel cylinder's actuating links outward. Since these links bear directly against the top of the brake shoes, the tops of the shoes are then forced against the inner side of the drum. This action forces the bottoms of the two shoes to contact the brake drum by rotating the entire assembly slightly (known as servo action). When pressure within the wheel cylinder is relaxed, return springs pull the shoes back away from the drum.

Most modern drum brakes are designed to self-adjust themselves during application when the vehicle is moving in reverse. This motion causes both shoes to rotate very slightly with the drum, rocking an adjusting lever, thereby causing rotation of the adjusting screw. Some drum brake systems are designed to self-adjust during application whenever the brakes are applied. This on-board adjustment system reduces the need for maintenance adjustments and keeps both the brake function and pedal feel satisfactory.



## POWER BOOSTERS

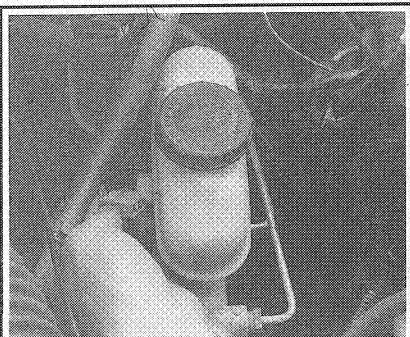
Virtually all modern vehicles use a vacuum assisted power brake system to multiply the braking force and reduce pedal effort. Since vacuum is always available when the engine is operating, the system is simple and efficient. A vacuum diaphragm is located on the front of the master cylinder and assists the driver in applying the brakes, reducing both the effort and travel he must put into moving the brake pedal. The vacuum diaphragm housing is normally connected to the intake manifold by a vacuum hose. A check valve is placed at the point where the hose enters the diaphragm housing, so that during periods of low manifold vacuum brakes assist will not be lost. Depressing the brake pedal closes off the vacuum source and allows atmospheric pressure to enter on one side of the diaphragm. This causes the master cylinder pistons to move and apply the brakes. When the brake pedal is released, vacuum is applied to both sides of the diaphragm and springs return the diaphragm and master cylinder pistons to the released position. If the vacuum supply fails, the brake pedal rod will contact the end of the master cylinder actuator rod and the system will apply the brakes without any power assistance. The driver will notice that much higher pedal effort is needed to stop the car and that the pedal feels harder than usual.

### Vacuum Leak Test

1. Operate the engine at idle without touching the brake pedal for at least one minute.
2. Turn off the engine and wait one minute.
3. Test for the presence of assist vacuum by depressing the brake pedal and releasing it several times. If vacuum is present in the system, light application will produce less and less pedal travel. If there is no vacuum, air is leaking into the system.

### System Operation Test

1. With the engine **OFF**, pump the brake pedal until the supply vacuum is entirely gone.
2. Put light, steady pressure on the brake pedal.
3. Start the engine and let it idle. If the system is operating correctly, the brake pedal should fall toward the floor if the constant pressure is maintained.



86879004

**Fig. 1** Disengage the electrical connector from the brake warning indicator

Power brake systems may be tested for hydraulic leaks just as ordinary systems are tested.

### WARNING

**Clean, high quality brake fluid is essential to the safe and proper operation of the brake system. You should always buy the highest quality brake fluid that is available. If the brake fluid becomes contaminated, drain and flush the system, then refill the master cylinder with new fluid. Never reuse any brake fluid. Any brake fluid that is removed from the system should be discarded.**

## Brake Light Switch

### REMOVAL & INSTALLATION

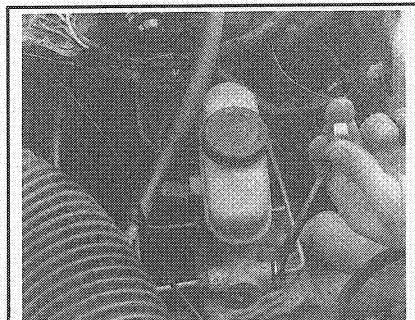
1. Disconnect the negative battery cable.
2. Disconnect the electrical connector at the switch. The locking tab on the connector must be lifted before the connector can be removed.
3. Remove the hairpin retainer, slide the brake light switch, the pushrod and the nylon washers and bushings away from the pedal and remove the switch.

➔ **Since the switch side plate nearest the brake pedal is slotted, it is not necessary to remove the brake master cylinder pushrod and 1 washer from the brake pedal pin.**

#### To install:

4. Position the switch so the U-shaped side is nearest the pedal and directly over/under the pin. Then slide the switch down/up trapping the master cylinder pushrod and black bushing between the switch side plates. Push the switch and pushrod assembly firmly toward the brake pedal arm. Assemble the outside white plastic washer to the pin and install the hairpin retainer to trap the whole assembly.
5. Assemble the wire harness connector to the switch. Check the switch for proper operation.

➔ **The brake light switch wire harness must be long enough to travel with the switch during full pedal stroke. If wire length is insufficient, reroute the harness or service, as required.**



86879005

**Fig. 2** Disconnect the brake lines from the primary and secondary outlet ports of the master cylinder

## Master Cylinder

### REMOVAL & INSTALLATION

#### 1988-94 Vehicles

➔ See Figures 1, 2, 3 and 4

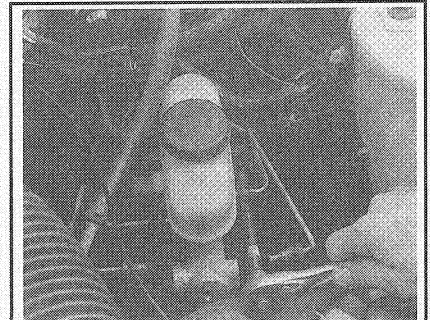
1. Disconnect the negative battery cable.
2. For vehicles equipped with ABS, apply the brake pedal a few times to exhaust all the vacuum in the system.
3. Disengage the brake warning indicator electrical connector.
4. Disconnect the brake lines from the primary and secondary outlet ports of the master cylinder and the brake pressure control valve.

➔ **The master cylinder on the 1988-89 Lincoln Continental is part of the anti-lock brake hydraulic actuation unit and cannot be removed separately.**

5. For vehicles equipped with ABS, disconnect the Hydraulic Control Unit (HCU) supply hose at the master cylinder, then secure in a position to prevent the loss of brake fluid.
6. Remove the nuts attaching the master cylinder to the brake booster assembly.
7. Slide the master cylinder forward and upward from the vehicle.

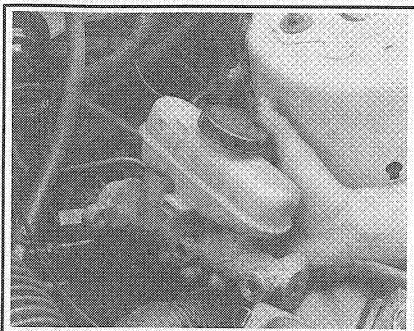
#### To install:

8. In order to ease installation, bench bleed the master cylinder before installation:
  - a. Mount the master cylinder in a holding fixture, such as a soft jawed vise. Be careful not to damage the master cylinder housing.
  - b. Fill the master cylinder with brake fluid.
  - c. Place a suitable container under the master cylinder to catch the fluid being expelled from the outlet ports. Using a suitable tool inserted into the booster pushrod cavity, push the master cylinder piston in slowly.
  - d. Place a finger tightly over each outlet port, then allow the master cylinder piston to return.
  - e. Repeat the procedure until only clear fluid is expelled from the master cylinder. Plug the outlet ports, then remove the master cylinder from the holding fixture.
9. For vehicles equipped with ABS, install a new seal in the groove in the master cylinder mounting face.

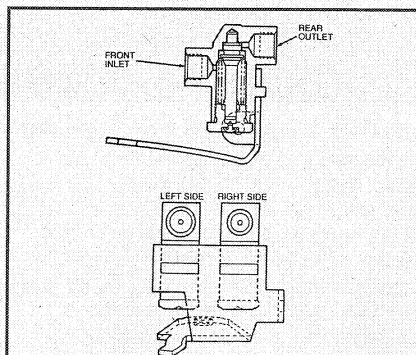


86879006

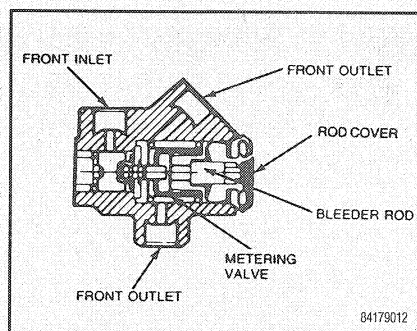
**Fig. 3** Remove the retaining nuts attaching the master cylinder to the brake booster assembly, then . . .



**Fig. 4 . . . slide the master cylinder assembly forward and upward from the vehicle**



**Fig. 5 Brake pressure control valve**



**Fig. 6 Metering valve—1989 vehicles and 1990–91 vehicles with 5.8L engine**

10. Mount the master cylinder over the booster pushrod and onto the two studs on the power brake booster assembly.

11. Install the retaining nuts, then tighten them to 16–21 ft. lbs. (21–29 Nm).

12. Attach the brake fluid lines to the master cylinder and the brake pressure control valve ports.

13. For vehicles equipped with ABS, install the HCU supply hose to the master cylinder fitting, then secure it with the hose clamp.

14. Connect the brake warning light wire.

15. Fill the brake master cylinder with DOT 3 brake fluid to 0.16 in. (4.0mm) below the MAX lines on the side of the reservoir.

16. Connect the negative battery cable, then bleed the brake system. For details, please refer to the procedure located later in this section.

17. Operate the brakes several times, then check for external hydraulic leaks.

### 1995–00 Vehicles

1. Disconnect the negative battery cable.

2. Depress the brake pedal several times to exhaust all vacuum in the power brake booster.

3. Remove and plug the brake lines from the primary and secondary outlet ports of the master cylinder.

4. Detach the brake warning indicator switch connector.

5. If equipped with ABS and traction assist, remove 2 bolts retaining the proportioning valve bracket to the master cylinder. Secure the proportioning valve and brake lines in a position to prevent damage or loss of brake fluid.

6. Remove 2 nuts retaining the brake master cylinder to the power brake booster assembly.

7. Slide the master cylinder forward and upward from the vehicle and remove.

#### To install:

8. If replacing the brake master cylinder, bench bleed the master cylinder before installation.

9. Install the brake master cylinder to the power brake booster mounting studs and install 2 retaining nuts. Torque the nuts to 16–21 ft. lbs. (21–29 Nm).

10. If equipped with ABS and traction assist, place the proportioning valve bracket in position and install 2 retaining bolts. Torque the bolts to 14–19 ft. lbs. (19–26 Nm).

11. Unplug and install the primary and sec-

ondary brake lines to the brake master cylinder outlet ports. Torque the brake line fittings to 10–15 ft. lbs. (14–20 Nm).

12. Reconnect the brake warning indicator switch connector.

13. Properly bleed the brake system using clean DOT 3 or equivalent, brake fluid from a closed container.

### CAUTION

**If raising the vehicle for brake bleeding and the vehicle is equipped with air suspension, the air suspension switch, located on the right-hand side of the luggage compartment, must be turned to the OFF position before raising the vehicle.**

14. Fill the master cylinder reservoir to the proper level.

15. Operate the brakes several times, then check for external hydraulic leaks.

16. Reconnect the negative battery cable.

17. If equipped with air suspension, turn the air suspension switch to the **ON** position, if disabled.

18. Road test the vehicle and check the brake system for proper operation.

### Brake Pressure Control Valve

#### REMOVAL & INSTALLATION

##### See Figure 5

1. Disconnect the brake inlet lines and the rear lines from the brake control valve assembly.

2. Remove the screw retaining the control valve assembly to the frame and remove the brake control valve.

#### To install:

3. Position the control valve on the frame and secure with the retaining screw.

4. Connect the rear brake outlet lines to the control valve assembly and tighten the line nuts to 10–18 ft. lbs. (14–24 Nm).

5. Connect the inlet lines to the control valve assembly and tighten the line nuts to 10–18 ft. lbs. (14–24 Nm).

6. Bleed the brake system.

### Metering Valve

#### REMOVAL & INSTALLATION

##### See Figure 6

1. Disconnect the front brake system inlet line and the left and right front brake outlet lines from the metering valve.

2. Remove the screw retaining the metering valve to the frame and remove the metering valve from the vehicle.

#### To install:

3. Position the metering valve on the frame and secure with the retaining screw. Tighten the screw to 7–11 ft. lbs. (10–14 Nm).

4. Connect the front brake outlet lines to the metering valve assembly and tighten the line nuts to 10–18 ft. lbs. (14–24 Nm).

5. Connect the front brake inlet line to the metering valve assembly and tighten the line nut to 10–18 ft. lbs. (14–24 Nm).

6. Bleed the brake system.

**➔ If the brake system is pressure bled, the metering valve bleeder rod must be pushed in.**

### Bleeding the Brake System

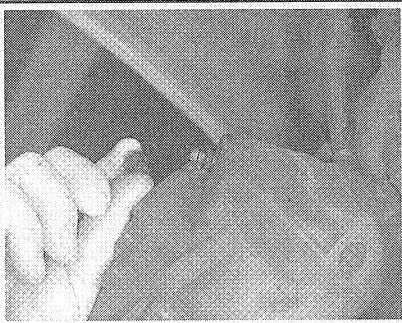
##### See Figures 7, 8, 9 and 10

When any part of the hydraulic system has been disconnected for repair or replacement, air may get into the lines and cause spongy pedal action (because air can be compressed and brake fluid cannot). To correct this condition, it is necessary to bleed the hydraulic system so to be sure all air is purged.

When bleeding the brake system, bleed one brake cylinder at a time, beginning at the cylinder with the longest hydraulic line (farthest from the master cylinder) first. ALWAYS keep the master cylinder reservoir filled with brake fluid during the bleeding operation. Never use brake fluid that has been drained from the hydraulic system, no matter how clean it is.

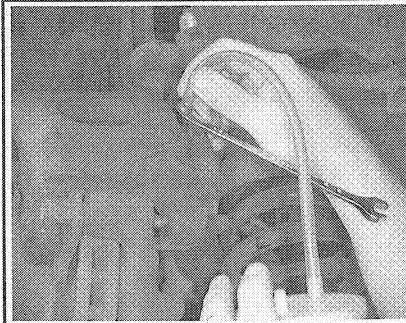
The primary and secondary hydraulic brake systems are separate and are bled independently. During the bleeding operation, do not allow the





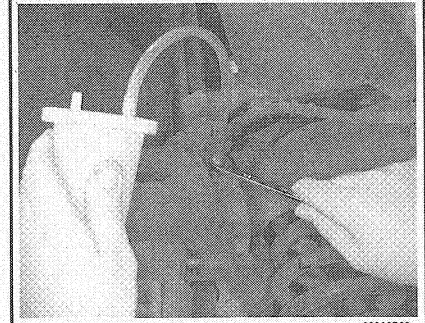
89609P01

**Fig. 7 Remove the bleeder screw rubber dust cover—front caliper**



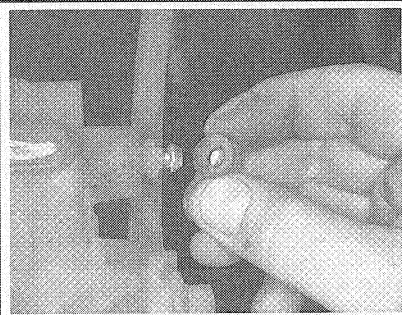
89609P02

**Fig. 8 Attach a length of rubber hose over the bleeder screw and place the other end of the hose in a glass jar**



89609P03

**Fig. 9 Open the bleeder valve using a suitable size wrench while an assistant depresses the brake pedal**



89609P38

**Fig. 10 Bleeder screw location—rear caliper**

reservoir to run dry. Keep the master cylinder reservoir filled with brake fluid.

1. Clean all dirt from around the master cylinder fill cap, remove the cap and fill the master cylinder with brake fluid until the level is within 1/4 in. (6mm) of the top edge of the reservoir.
2. Clean the bleeder screws at all 4 wheels. The bleeder screws are located on the back of the brake backing plate (drum brakes) and on the top of the brake calipers (disc brakes).
3. Attach a length of rubber hose over the bleeder screw and place the other end of the hose in a glass jar, submerged in brake fluid.
4. Open the bleeder screw 1/2–3/4 turn. Have an assistant slowly depress the brake pedal.

5. Close the bleeder screw and tell your assistant to allow the brake pedal to return slowly. Continue this process to purge all air from the system.

6. When bubbles cease to appear at the end of the bleeder hose, close the bleeder screw and remove the hose. Tighten the bleeder screw to the proper torque.

7. Check the master cylinder fluid level and add fluid accordingly. Do this after bleeding each wheel.

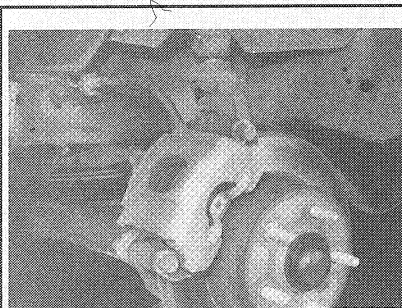
8. Repeat the bleeding operation at the remaining 3 wheels, ending with the one closest to the master cylinder.

9. Fill the master cylinder reservoir to the proper level.

## DISC BRAKES

### \*\* CAUTION

Older brake pads or shoes may contain asbestos, which has been determined to be cancer-causing agent. Never clean the brake surfaces with compressed air! Avoid inhaling any dust from any brake surface! When cleaning brake surfaces, use a commercially available brake cleaning fluid. Also use this caution:



84179016

**Fig. 11 Front disc brake caliper**

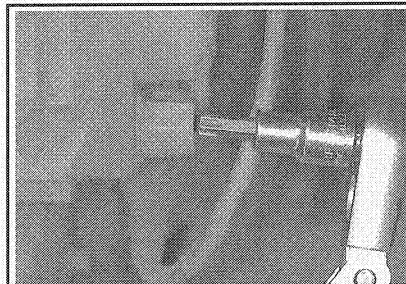
### Brake Pads

#### REMOVAL & INSTALLATION

##### Front

♦ See Figures 11 thru 16

1. Remove and discard half the brake fluid from the master cylinder. Properly dispose of the used brake fluid.



93149P20

**Fig. 12 This Continental uses a Torx® driver to remove the caliper pins. Make sure the proper size is used and the driver is seated in the pin tightly**

2. Raise and safely support vehicle. Remove the front wheel and tire assemblies.

3. Remove the caliper locating pins and remove the caliper from the anchor plate and rotor, but do not disconnect the brake hose.

4. Remove the outer brake pad from the caliper assembly and remove the inner brake pad from the caliper piston.

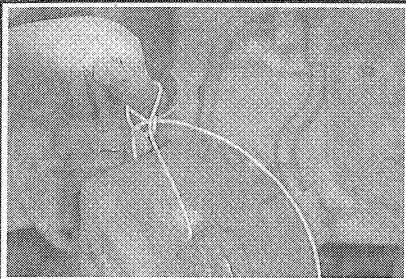
5. Inspect the disc brake rotor for scoring and wear. Replace or machine, as necessary.

6. Suspend the caliper inside the fender hous-



93149P06

**Fig. 13 When the pins have been removed, the caliper slides off the rotor. If the rotor has been scored, the caliper may be a little tough to remove. Use a small pry tool if necessary**



93149P10

**Fig. 14** Use a length of wire or an old coat hanger to suspend the caliper. Do not allow the weight of the caliper to hang on the brake hose

ing with a length of wire. Do not let the caliper hang by the brake hose.

**To install:**

7. Use a large C-clamp and wood block to push the caliper piston back into its bore.

**\*\*\* WARNING**

**Never apply the C-clamp directly to the phenolic caliper piston; damage to the piston may result.**

8. Install new locating pin insulators in the caliper housing. Check to see if both insulator flanges straddle the housing holes.

**Do not attempt to install the rubber insulators with a sharp edged tool.**

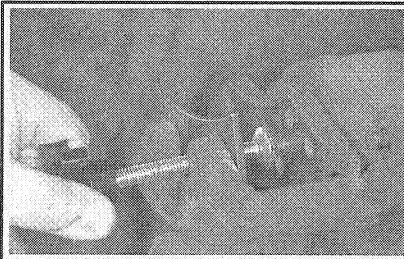
9. Install the inner brake pad in the caliper piston. Be careful not to bend the pad clips in the piston, or distortion and rattles can result.

10. Install the outer brake pad, making sure the clips are properly seated. The outer pads are marked left-hand (LH) and right-hand (RH) and must be installed in the proper caliper.

**Make sure that the large diameter of the pins is through the outer pad hole to prevent possible binding or bending.**

11. Install the caliper over the rotor with the outer brake pad against the rotor's braking surface. This prevents pinching the piston boot between the inner brake pad and the piston.

12. Lubricate the caliper locating pins and the



93149P08

**Fig. 15** This special collapsing tool is readily available at the local parts store. It will fit many different vehicles. Leave the old shoe in place when collapsing the piston into the caliper

inside of the locating pin insulators with silicone dielectric grease. Install the caliper locating pins and thread them into the spindle/anchor plate assembly by hand.

13. Tighten the caliper locating pins to 45–65 ft. lbs. (61–88 Nm).

14. Install the wheel and tire assembly. Lower the vehicle.

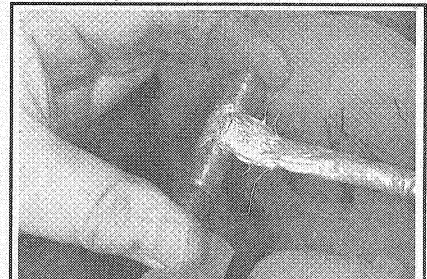
15. Pump the brake pedal prior to moving the vehicle to seat the brake pads. Refill the master cylinder.

16. Road test the vehicle.

**Rear**

**See Figures 17 thru 25**

1. Turn the air suspension service off.
2. Raise and safely support the rear of the vehicle securely on jackstands.
3. Remove the wheel and tire assembly.
4. Remove the bolt retaining rear brake hose support bracket, where necessary.
5. Remove the retaining clip from the parking brake rear cable an conduit at the rear disc brake caliper.
6. Remove the cable end from the parking brake lever.
7. Remove the upper disc brake caliper-locating pin.
8. Remove the lower disc brake caliper-locating pin.
9. Rotate the rear disc brake caliper away from the rear disc brake rotor.



93149P09

**Fig. 16** When replacing brakes, make sure to service the caliper pins. Lube the pins with special "brake" grease that has a silicone compound base

10. Remove the inner and outer rear brake shoe and lining assemblies from the rear disc support bracket.

**Unless the tabs on the back of the brake pads are seated in the slots of the piston, and the piston seated in the caliper, the brake pads and the caliper will not fit into the disc support bracket.**

**To install:**

11. Make sure that one of the two slots in the piston face is positioned so it will engage the nib on the brake shoe.

12. Using the rear caliper piston adjuster rotate the piston clockwise while applying pressure inward, until it is fully seated.

13. Install the inner and outer rear brake shoe and lining assemblies in the rear disc support bracket.

14. Rotate the rear disc brake caliper over the rear disc brake rotor into position on the rear disc support bracket. Make sure that the rear brake shoe and lining assemblies are installed correctly.

15. Remove any residue from the rear brake pin retainer bolt threads and apply one drop of a thread sealer. Install the disc brake caliper locating pin and tighten.

16. Attach the cable end to the parking brake lever. Install the cable retaining clip on the rear disc brake caliper.

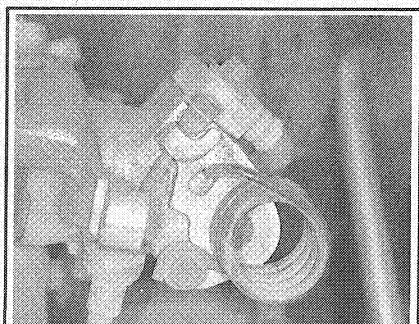
17. Position the rear wheel brake hose to the side rail and install the retaining bolt.

18. Install the wheel and tire assembly.



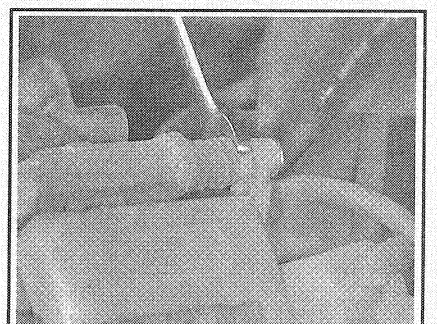
93149P36

**Fig. 17** Pull the caliper out of the support bracket and support it. Notice the brake pads stay in the support bracket, they are not attached to the caliper



93149P22

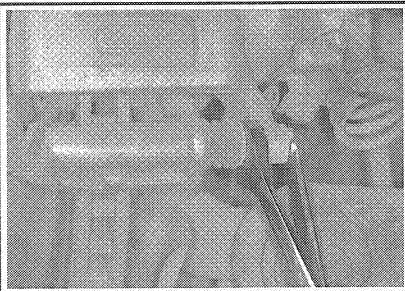
**Fig. 18** This is the rear caliper with the parking brake cable ready to be unhooked



93149P39

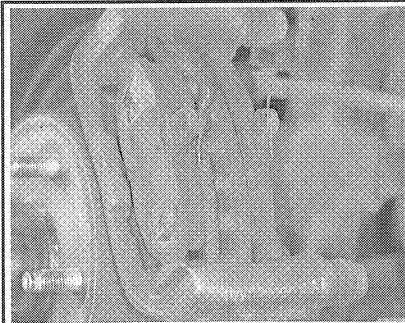
**Fig. 19** Removing the upper disc caliper locating pin, using an open end and a box end wrench





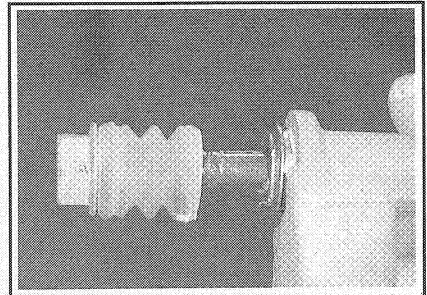
93149P37

**Fig. 20** Removing the lower disc caliper locating pin. This application used a 10 mm box wrench and a 15 mm open end wrench



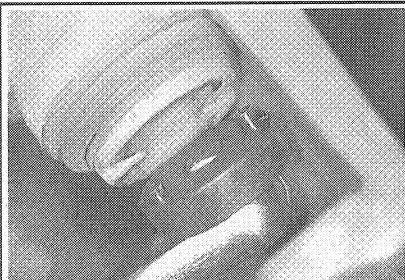
93149P32

**Fig. 21** With the brake caliper removed, you can see the way the brake pads are mounted in the support bracket



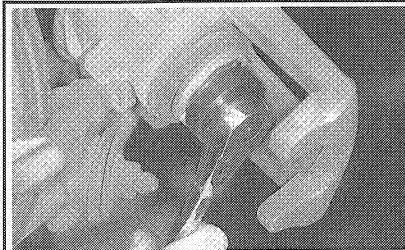
93149P28

**Fig. 22** Replacing the brake pads, is a good time to service the caliper pins. Use a brake grease compound with a silicone base to lube the pins



93149P35

**Fig. 23** The parking brake is built into the rear caliper requiring a special tool for brake installation, the piston has to be twisted into the boot



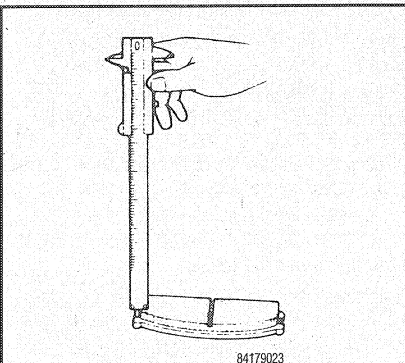
93149P34

**Fig. 24** To collapse the piston back into the caliper, align the two pins in the special tool to the piston's two slots and screw it back in slowly, while applying an inward pressure to the piston



93149P41

**Fig. 25** When the piston is pushed into the piston and seated, be sure the piston's slots are at 6 and 12 o'clock. There are two tabs on the back of the pad that seat in the slots



84179023

**Fig. 26** Checking disc brake pad thickness

19. Lower the vehicle and turn the air suspension on.

## INSPECTION

▶ See Figure 26

Inspect the disc brake pads for oil or grease contamination, abnormal wear or cracking, and for deterioration or damage due to heat. Check the thickness of the pads; the minimum allowable thickness is  $\frac{1}{8}$  in. Always replace the brake pads in axle sets; never replace just one pad of a brake assembly.

## Brake Caliper

### REMOVAL & INSTALLATION

#### Front

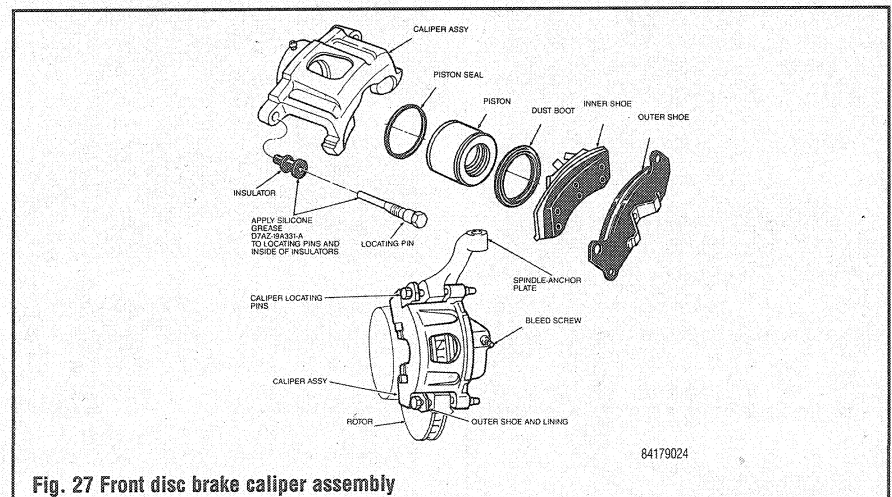
▶ See Figure 27

1. Raise and safely support the vehicle. Remove the front wheel and tire assembly.

2. Loosen the brake line fitting that connects the brake hose to the brake line at the frame bracket. Plug the brake line. Remove the retaining clip from the hose and bracket and disengage the hose from the bracket.

3. Remove the hollow bolt attaching the brake hose to the caliper and remove the brake hose. Discard the sealing washers.

4. Remove the caliper locating pins and remove the caliper. If removing both calipers, mark the right and left sides so they may be reinstalled correctly.



**Fig. 27** Front disc brake caliper assembly

## To install:

5. Install the caliper over the rotor with the outer brake pad against the rotor's braking surface. This prevents pinching the piston boot between the inner brake pad and the piston.
6. Lubricate the locating pins and the inside of the locating pin insulators with silicone dielectric grease. Install the caliper locating pins and thread them into the spindle/anchor plate assembly by hand.
7. Tighten the caliper locating pins to 45–65 ft. lbs. (61–88 Nm).
8. Install new sealing washers on each side of the brake hose fitting outlet and install the hollow bolt, through the hose fitting and into the caliper. Tighten the bolt to 30 ft. lbs. (41 Nm).
9. Position the other end of the brake hose in the bracket and install the retaining clip. Make sure the hose is not twisted.
10. Remove the plug from the brake line, connect the brake line to the brake hose and tighten the fitting nut to 10–18 ft. lbs. (13–24 Nm).
11. Bleed the brake system, install the wheel and tire assembly and lower the vehicle.
12. Apply the brake pedal several times before moving the vehicle, to position the brake pads.
13. Road test the vehicle.

## Rear

### See Figures 28 and 29

1. Raise and safely support the vehicle.
2. Remove the rear wheel and tire assembly.
3. Remove the brake fitting retaining bolt from the caliper and disconnect the flexible brake hose from the caliper. Plug the hose and the caliper fitting.
4. Remove the caliper locating pins. Lift the caliper off the rotor and anchor plate using a rotating motion.

## WARNING

Do not pry directly against the plastic piston or damage to the piston may occur.

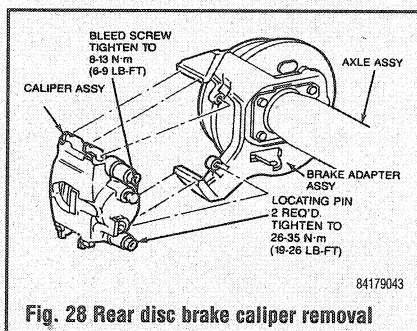


Fig. 28 Rear disc brake caliper removal

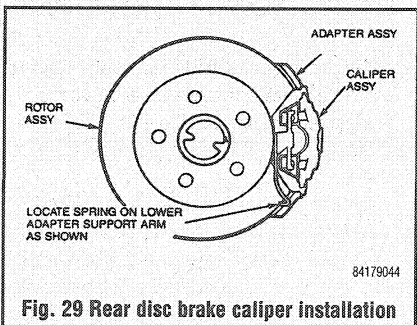


Fig. 29 Rear disc brake caliper installation

## To install:

5. Position the caliper assembly above the rotor with the anti-rattle spring located on the lower adapter support arm. Install the caliper over the rotor with a rotating motion. Make sure the inner pad is properly positioned.
6. Install the caliper locating pins and start them in the threads by hand. Tighten them to 19–26 ft. lbs. (26–35 Nm).
7. Install the brake hose on the caliper with a new gasket on each side of the fitting outlet. Insert the retaining bolt and tighten to 30–40 ft. lbs. (40–54 Nm).
8. Bleed the brake system, install the wheel and tire assembly and lower the vehicle.
9. Pump the brake pedal prior to moving the vehicle to position the linings.
10. Road test the vehicle.

## Brake Disc (Rotor)

### REMOVAL & INSTALLATION

#### 1988–91 Vehicles

##### See Figure 30

1. Raise and safely support the vehicle.
2. Remove the wheel and tire assembly.
3. Remove the caliper from the spindle and rotor, but do not disconnect the brake hose. Suspend the caliper inside the fender housing with a length of wire. Do not let the caliper hang by the brake hose.
4. Remove the grease cap from the hub and remove the cotter pin, nut retainer and adjusting nut.
5. Grasp the hub/rotor assembly and pull it out far enough to loosen the washer and outer wheel bearing. Push the hub/rotor assembly back onto the spindle and remove the washer and outer wheel bearing.
6. Remove the hub/rotor assembly from the spindle.
7. Inspect the rotor for scoring and wear. Replace or machine as necessary. If machining, observe the minimum thickness specification.

#### To install:

8. If the rotor is being replaced, remove the

protective coating from the new rotor with brake cleaner. Pack a new set of bearings with high-temperature wheel bearing grease and install the inner roller bearing in the inner cup. Pack grease lightly between the lips of a new seal and install the seal, using a seal installer.

9. If the original rotor is being installed, make sure the grease in the hub is clean and adequate, the inner bearing and grease seal are lubricated and in good condition, and the rotor braking surfaces are clean.

10. Install the hub/rotor assembly on the spindle. Keep the assembly centered on the spindle to prevent damage to the grease seal or spindle threads.

11. Install the outer wheel bearing, washer and adjusting nut. Adjust the wheel bearings according to the procedure in Section 8, then install the nut retainer, cotter pin and grease cap.

12. Install the caliper and the wheel and tire assembly. Lower the vehicle.

13. Apply the brake pedal several times before moving the vehicle, to position the brake pads.

#### 1992–99 Vehicles

##### See Figures 31 thru 36

1. Raise and safely support the vehicle.
2. Remove the wheel and tire assembly.
3. Remove the caliper from the spindle and rotor, but do not disconnect the brake hose. Suspend the caliper inside the fender housing with a length of wire. Do not let the caliper hang by the brake hose.
4. Remove the rotor retaining push nuts, if equipped, and remove the rotor from the hub.
5. Inspect the rotor for scoring and wear. Replace or machine as necessary. If machining, observe the minimum thickness specification.

#### To install:

6. If the rotor is being replaced, remove the protective coating from the new rotor with brake cleaner. If the original rotor is being installed, make sure the braking surfaces are clean.
7. Install the rotor on the hub.
8. Install the caliper and the wheel and tire assembly. Lower the vehicle.

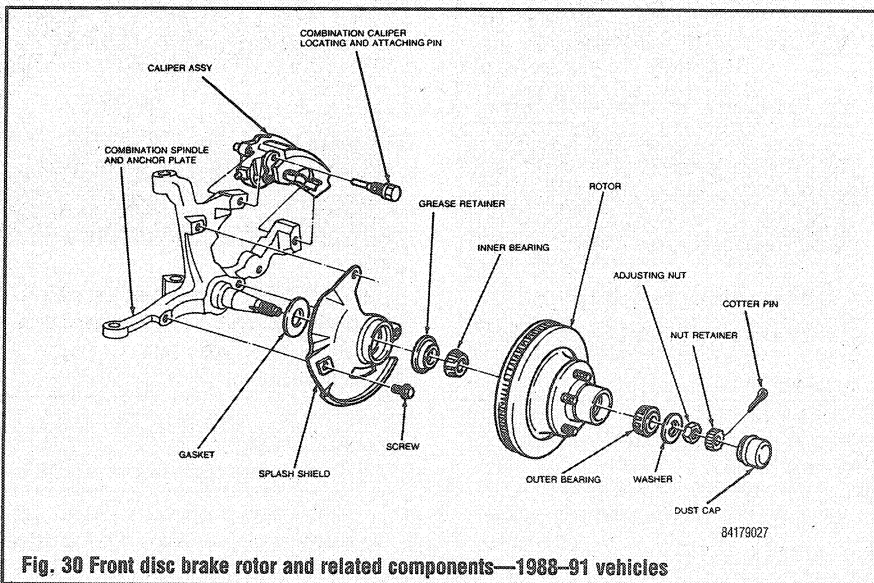
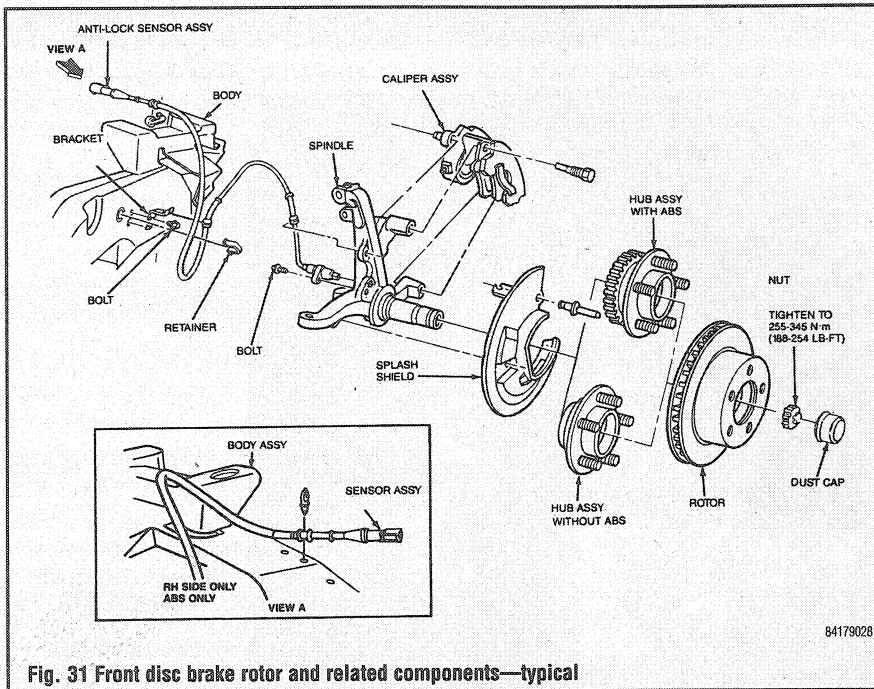


Fig. 30 Front disc brake rotor and related components—1988–91 vehicles





**Fig. 31 Front disc brake rotor and related components—typical**

9. Apply the brake pedal several times before moving the vehicle, to position the brake pads.

## INSPECTION

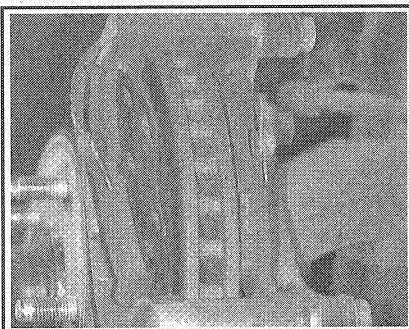
Check the disc brake rotor for scoring, cracks or other damage. Check the minimum thickness and rotor runout.

Either foreign material build-up or contamination on the rotor braking surface or uneven rotor thickness causes a brake pulsation that is present during brake application. If there is a foreign material build-up or contamination found on the rotor or lining surfaces, hand sand the linings and rotors. Uneven rotor thickness (thickness variation) may be caused by excessive runout, caliper drag or the abrasive action of the brake lining. If brake pulsation is present, attempt stopping the vehicle with the transmission in the NEUTRAL position. If the pulsation is gone, the drivetrain should be inspected. If the pulsation remains, inspect the brakes.

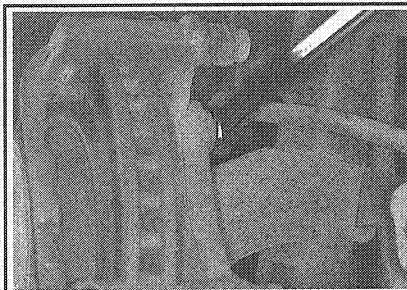
Check the rotor thickness using a micrometer or calipers. The brake rotor minimum thickness must not be less than 0.972 in. on 1988–91 vehicles or 0.974 in. on 1992–99 vehicles.

Rotor runout can be checked using a dial indicator. Mount the indicator to the spindle or upper control arm and position the indicator foot on the center of the braking surface. Rotate the rotor to check the runout. On 1992–99 vehicles, make sure there is no rust or foreign material between the rotor and hub face. Hold the rotor to the hub by inverting the lugnuts and tightening them to 85–105 ft. lbs. (115–142 Nm). Rotor runout must not exceed 0.003 in.

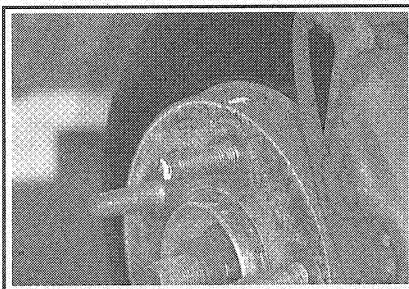
If rotor runout exceeds specification on 1988–91 vehicles, machine the rotor if it will not be below the minimum thickness specification after machining. On 1992–00 vehicles, the rotor can be repositioned on the hub to obtain the lowest possible runout. If runout remains excessive, remove the rotor and check the hub runout. Replace the hub if hub runout exceeds 0.002 in. If after replacing the hub, rotor runout remains excessive, machine the rotor if it will not be below the minimum thickness specification after machining.



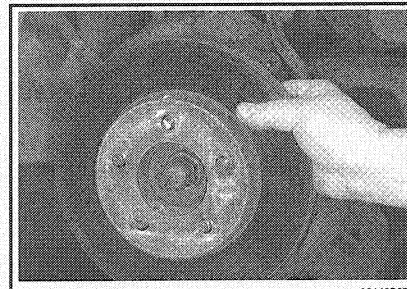
**Fig. 32 After removing the disc pads you can inspect the brake rotor thoroughly for scoring**



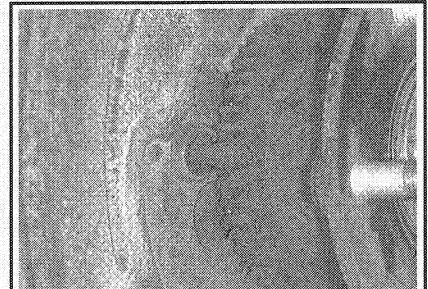
**Fig. 33 If the rotor has to come off, the disc support bracket has to be removed. This bracket has two bolts that hold it in place**



**Fig. 34 Before removing the caliper, matchmark the rotor and the stud (lug) to help prevent vibration from a rotor that is out of round**

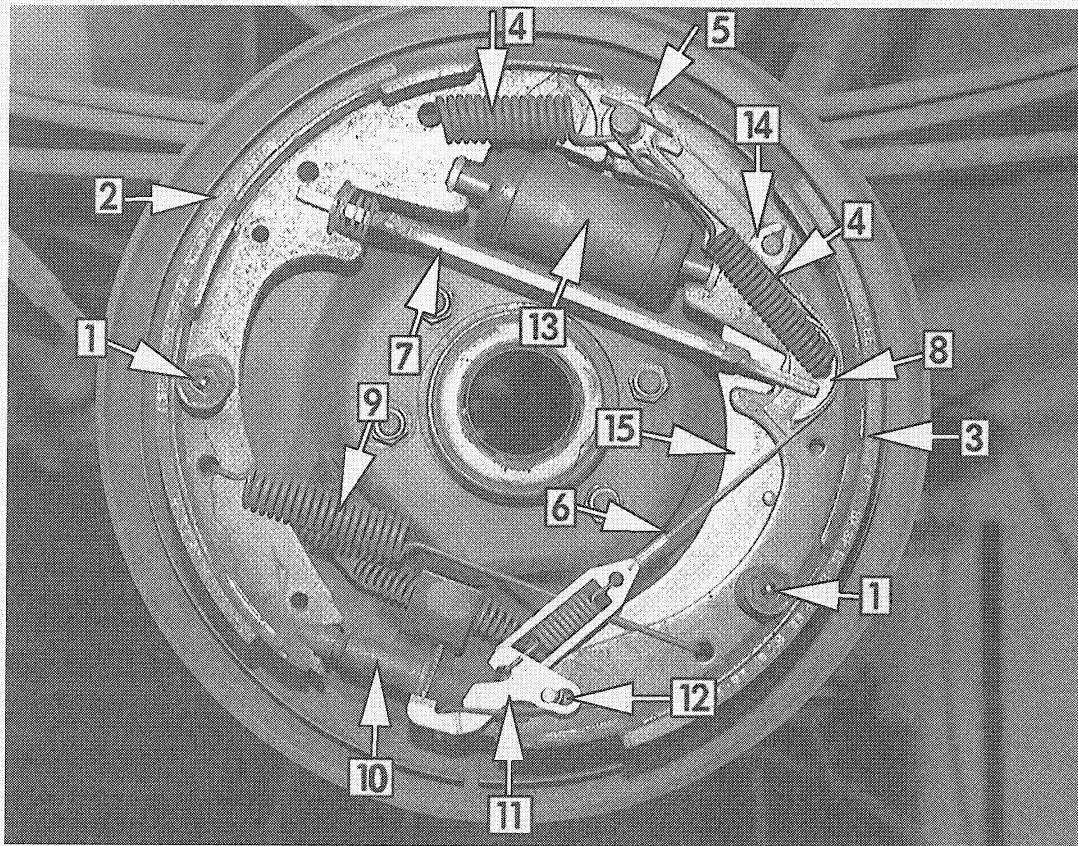


**Fig. 35 To remove the rotor, just slide it off the hub. Make sure it is marked on a stud and on the rotor "hat" for proper installation**



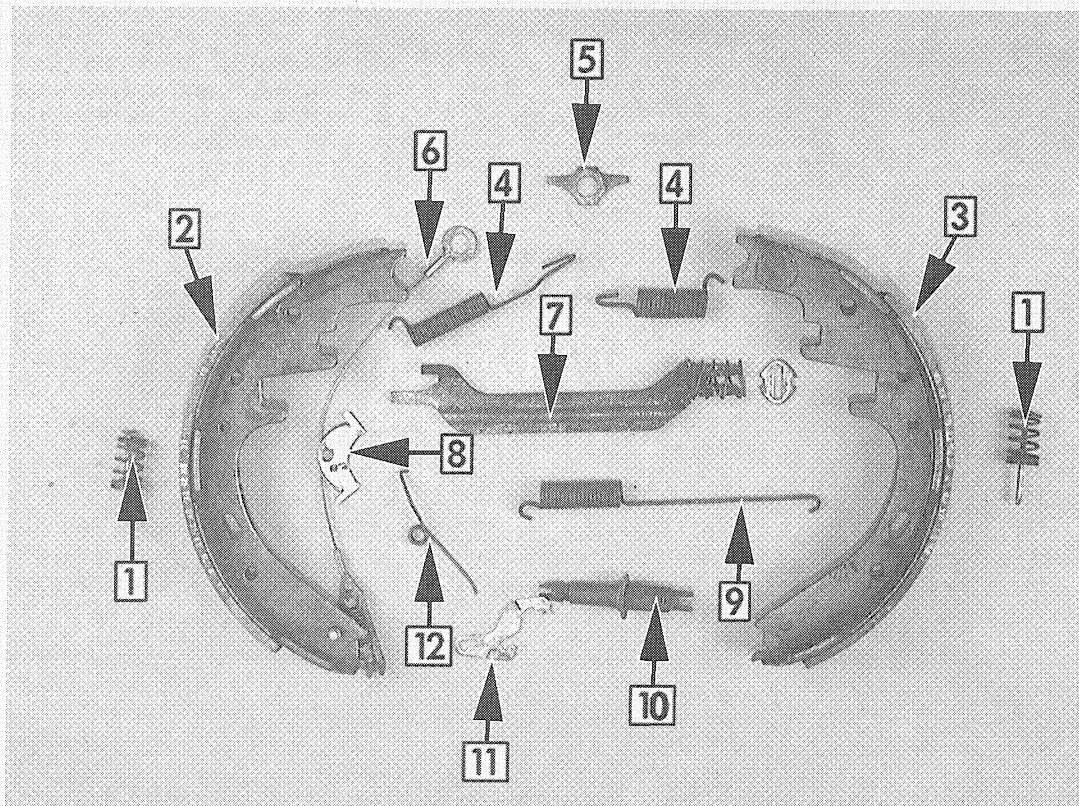
**Fig. 36 When the rotor has been removed, the anti-lock hub and sensor can be cleaned and inspected**

## DRUM BRAKES



### REAR DRUM BRAKE COMPONENTS

1. Shoe hold-down spring and retainer
2. Primary brake shoe
3. Secondary brake shoe
4. Brake shoe retracting springs
5. Anchor pin guide plate
6. Shoe adjusting lever cable
7. Parking brake strut
8. Shoe adjusting lever cable guide
9. Brake shoe adjusting screw spring
10. Brake adjuster screw
11. Brake shoe adjusting lever
12. Adjusting lever return spring
13. Wheel cylinder
14. Parking brake lever retaining clip
15. Parking brake lever





## \*\*\* CAUTION

Older brake pads or shoes may contain asbestos, which has been determined to be cancer causing agent. Never clean the brake surfaces with compressed air! Avoid inhaling any dust from any brake surface! When cleaning brake surfaces, use a commercially available brake cleaning fluid.

## Brake Drums

### REMOVAL & INSTALLATION

▶ See Figure 37

## \*\*\* CAUTION

Older brake pads or shoes may contain asbestos, which has been determined to be cancer causing agent. Never clean the brake surfaces with compressed air! Avoid inhaling any dust from any brake surface! When cleaning brake surfaces, use a commercially available brake cleaning fluid.

1. Raise and safely support the vehicle securely on jackstands.
2. Remove the tire and wheel assembly.
3. Remove the three retaining clips (if equipped), then remove the brake drum.

➔ It may be necessary to back off the brake shoe adjustment in order to remove the brake drum. This is because the drum might be grooved or worn from being in service for an extended period of time.

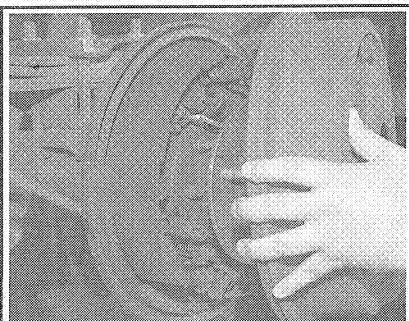
➔ Before installing a new brake drum, be sure to remove any protective coating with brake cleaner or a suitable fast-drying degreaser.

4. Install the brake drum in the reverse order of removal, then adjust the brakes as outlined later in this section.

### INSPECTION

▶ See Figures 38 and 39

Check that there are no cracks or chips in the braking surface. Excessive bluing indicates overheating and a replacement drum is needed. The



91199P01

Fig. 37 Lift the brake drum from the shoes and backing plate

drum can be machined to remove minor damage and to establish a rounded braking surface on a warped drum. Never exceed the maximum oversize of the drum when machining the braking surface.

## \*\*\* CAUTION

Older brake pads or shoes may contain asbestos, which has been determined to be cancer causing agent. Never clean the brake surfaces with compressed air! Avoid inhaling any dust from any brake surface! When cleaning brake surfaces, use a commercially available brake cleaning fluid.

The brake drum inside diameter and run-out can be measured using a brake drum micrometer. The drum should be measured every time a brake inspection is performed. Take the inside diameter readings at points 90° apart from each other on the drum to measure the run-out. The maximum inside diameter is stamped on the rim of the drum or on the inside above the lug nut stud holes and is also contained in the brake specifications chart at the end of this section.

## Brake Shoes

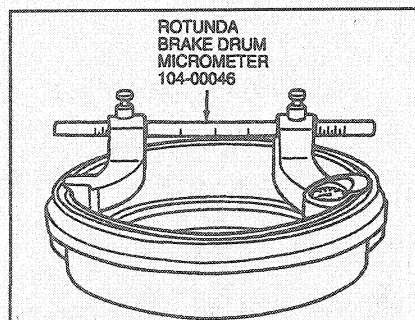
### INSPECTION

▶ See Figure 40

## \*\*\* CAUTION

Older brake pads or shoes may contain asbestos, which has been determined to be cancer causing agent. Never clean the brake surfaces with compressed air! Avoid inhaling any dust from any brake surface! When cleaning brake surfaces, use a commercially available brake cleaning fluid.

Inspect the brake shoes for wear using a ruler or Vernier caliper. Compare measurements to the brake specifications chart. If the lining is thinner than specification or there is evidence of the lining being contaminated by brake fluid or oil, repair the leak and replace all brake shoe assemblies (a complete axle set). In addition to the shoes inspect all springs and brake shoe hardware for wear and replace as necessary.



91059G16

Fig. 38 Measure the drum using a micrometer made especially for brake drums

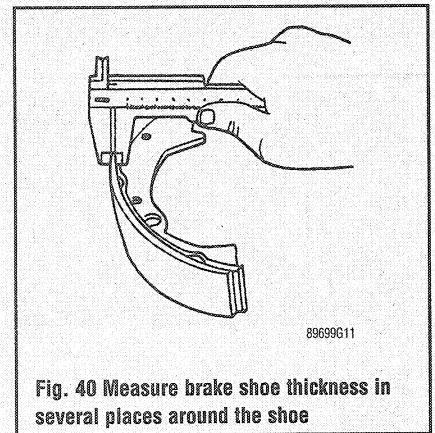


Fig. 40 Measure brake shoe thickness in several places around the shoe

### REMOVAL & INSTALLATION

▶ See Figures 41 thru 59

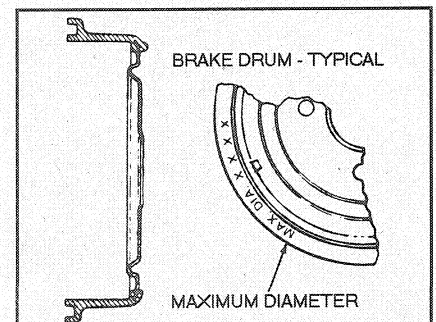
1. Raise and safely support the vehicle securely on jackstands.
2. Remove the wheel and tire assembly, then remove the brake drum.

➔ When servicing drum brakes, only disassemble and assemble one side at a time, leaving the remaining side intact for reference.

## \*\*\* CAUTION

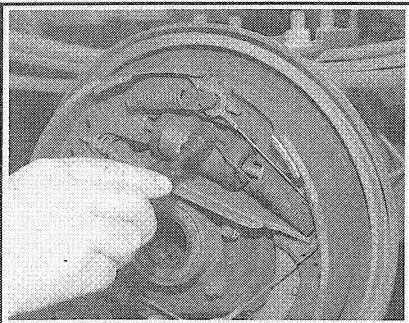
Older brake pads or shoes may contain asbestos, which has been determined to be cancer causing agent. Never clean the brake surfaces with compressed air! Avoid inhaling any dust from any brake surface! When cleaning brake surfaces, use a commercially available brake cleaning fluid.

3. Contract the brake shoes by pulling the self-adjusting lever away from the starwheel adjustment screw and turn the starwheel up and back until the pivot nut is drawn onto the starwheel as far as it will come.
4. Pull the adjusting lever, cable and automatic adjuster spring down and toward the rear to unhook the pivot hook from the large hole in the secondary shoe web. Do not attempt to pry the pivot hook from the hole.
5. Remove the automatic adjuster spring and the adjusting lever.
6. Remove the secondary shoe-to-anchor



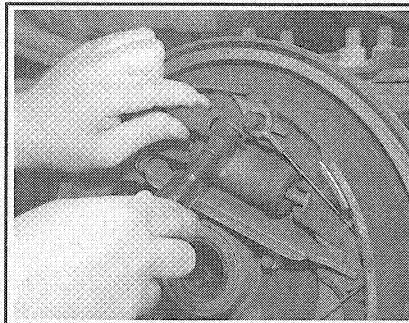
84929005

Fig. 39 Brake drum maximum diameter location



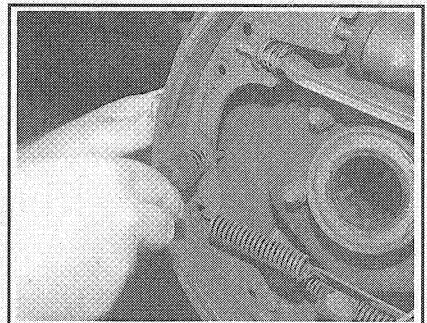
91199P04

**Fig. 41** Remove the brake shoe retracting springs . . .



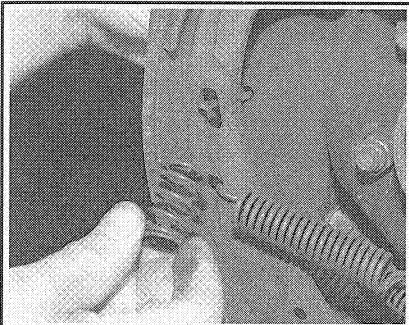
91199P05

**Fig. 42** . . . from both sides



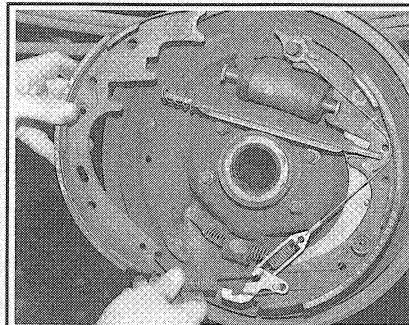
91199P06

**Fig. 43** Rotate the hold down spring retainer and . . .



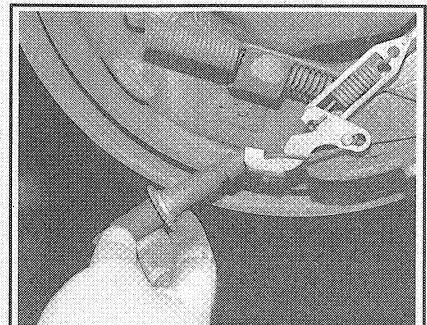
91199P07

**Fig. 44** . . . remove the hold down spring from the primary brake shoe



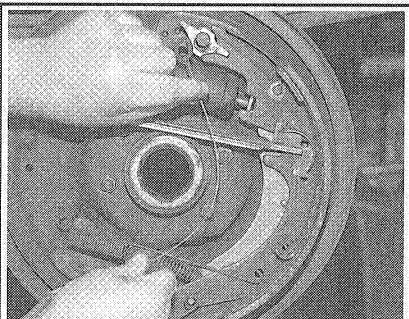
91199P08

**Fig. 45** Remove the primary shoe and unhook the adjusting spring from the shoe



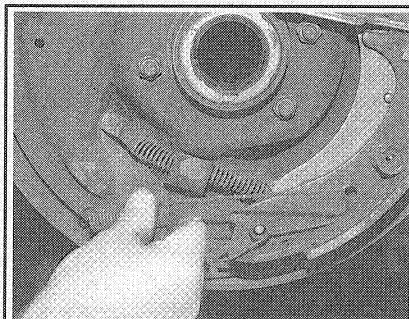
91199P09

**Fig. 46** Remove the adjusting screw



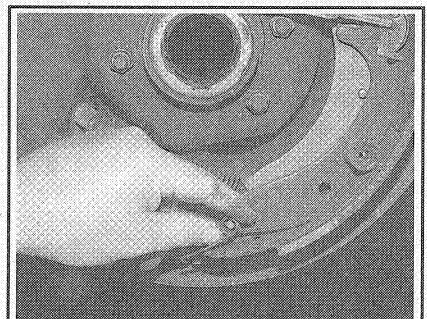
91199P10

**Fig. 47** Remove the brake shoe adjusting lever cable



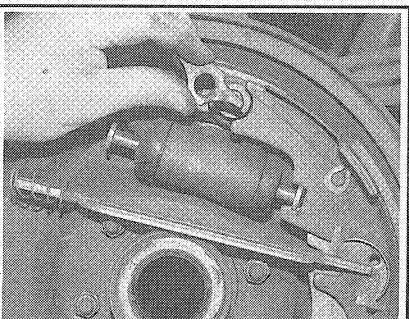
91199P11

**Fig. 48** Remove the adjusting spring



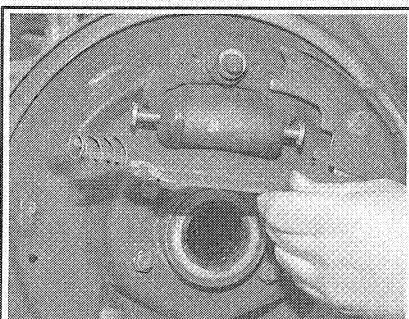
91199P12

**Fig. 49** Remove the adjusting lever return spring



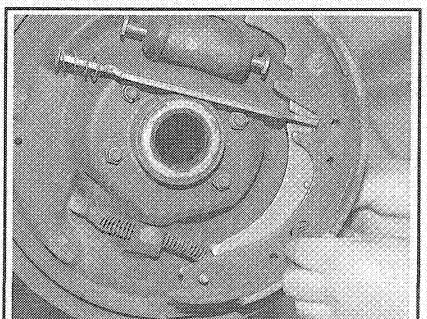
91199P13

**Fig. 50** Remove the anchor pin guide plate



91199P15

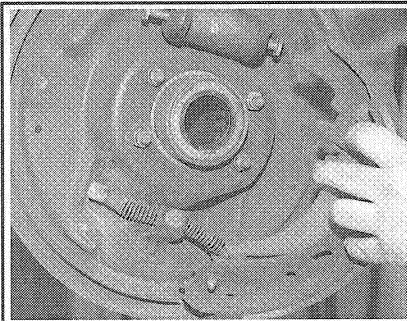
**Fig. 51** Remove the parking brake strut



91199P14

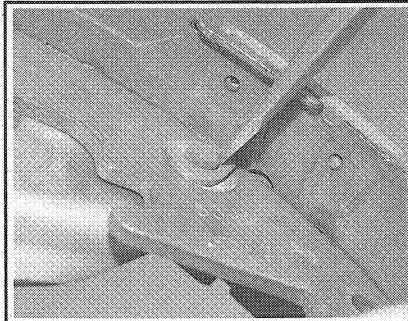
**Fig. 52** Remove the secondary shoe hold down spring and . . .





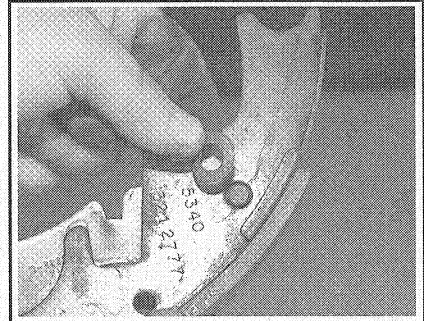
91199P16

**Fig. 53 . . . lift the secondary shoe from the backing plate**



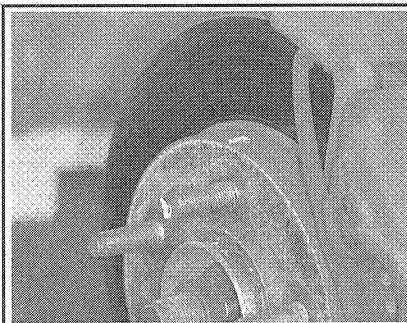
91199P17

**Fig. 54 Remove the parking brake lever horseshoe clip and . . .**



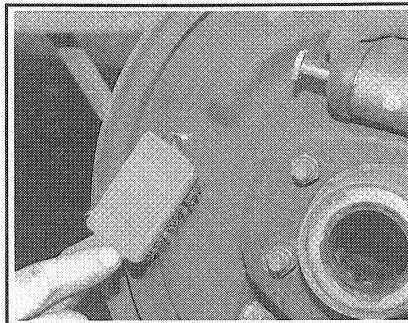
91199P18

**Fig. 55 . . . remove the washer from under the horseshoe clip**



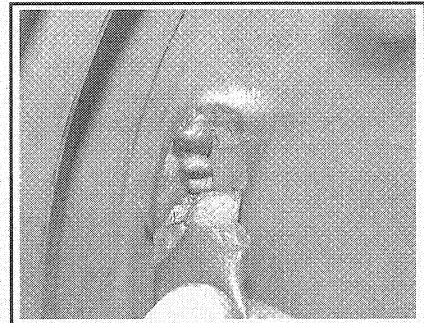
91199P19

**Fig. 56 Remove the secondary brake shoe from the parking brake lever**



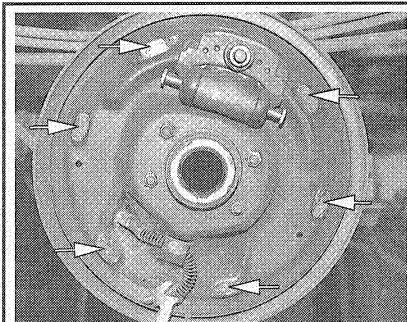
91199P20

**Fig. 57 Thoroughly clean and . . .**



91199P21

**Fig. 58 . . . lubricate the . . .**



91199P22

**Fig. 59 . . . shoe contact points on the backing plate**

spring. Remove the primary shoe-to-anchor spring and unhook the cable anchor. Remove the anchor pin plate.

7. Remove the cable guide from the secondary shoe.

8. Remove the shoe hold-down springs, shoes, adjusting screw, pivot nut, and socket. Note the color of each hold-down spring for assembly. To remove the hold-down springs, reach behind the brake backing plate and place one finger on the end of one of the brake hold-down spring mounting pins. Using a pair of pliers, grasp the washer type retainer on top of the hold-down spring that corresponds to the pin which you are holding. Push down on the pliers and turn them 90° to align the

slot in the washer with the head on the spring mounting pin. Remove the spring and washer retainer and repeat this operation on the hold down spring on the other shoe.

9. Remove the parking brake link and spring. Disconnect the parking brake cable from the parking brake lever.

10. After removing the rear brake secondary shoe, disassemble the parking brake lever from the shoe by removing the retaining clip and spring washer.

**To install:**

11. Assemble the parking brake lever to the secondary shoe and secure it with the spring washer and retaining clip.

12. Apply a light coating of Lubriplate®, or equivalent, at the points where the brake shoes contact the backing plate.

13. Position the brake shoes on the backing plate, and install the hold-down spring pins, springs, and spring washer type retainers. On the rear brake, install the parking brake link, spring and washer. Connect the parking brake cable to the parking brake lever.

14. Install the anchor pin plate, and place the cable anchor over the anchor pin with the crimped side toward the backing plate.

15. Install the primary shoe-to-anchor spring with the brake tool.

16. Install the cable guide on the secondary shoe web with the flanged holes fitted into the hole in the secondary shoe web. Thread the cable around the cable guide groove.

17. Install the secondary shoe-to-anchor (long)

spring. Be sure that the cable end is not cocked or binding on the anchor pin when installed. All of the parts should be flat on the anchor pin. Remove the wheel cylinder piston clamp.

18. Apply Lubriplate®, or equivalent, to the threads and the socket end of the adjusting star-wheel screw. Turn the adjusting screw into the adjusting pivot nut to the limit of the threads and then back off ½ turn.

**Interchanging the brake shoe adjusting screw assemblies from one side of the vehicle to the other would cause the brake shoes to retract rather than expand each time the automatic adjusting mechanism is operated. To prevent this, the socket end of the adjusting screw is stamped with an "R" or an "L" for "RIGHT" or "LEFT". The adjusting pivot nuts can be distinguished by the number of lines machined around the body of the nut; one line indicates left hand nut and two lines indicate a right hand nut.**

19. Place the adjusting socket on the screw and install this assembly between the shoe ends with the adjusting screw nearest to the secondary shoe.

20. Place the cable hook into the hole in the adjusting lever from the backing plate side. The adjusting levers are stamped with an **R** (right) or a **L** (left) to indicate their installation on the right or left hand brake assembly.

21. Position the hooked end of the adjuster spring in the primary shoe web and connect the loop end of the spring to the adjuster lever hole.

22. Pull the adjuster lever, cable and automatic

adjuster spring down toward the rear to engage the pivot hook in the large hole in the secondary shoe web.

23. After installation, check the action of the adjuster by pulling the section of the cable guide and the adjusting lever toward the secondary shoe web far enough to lift the lever past a tooth on the adjusting screw starwheel. The lever should snap into position behind the next tooth, and release of the cable should cause the adjuster spring to return the lever to its original position. This return action of the lever will turn the adjusting screw starwheel one tooth. The lever should contact the adjusting screw starwheel one tooth above the centerline of the adjusting screw.

If the automatic adjusting mechanism does not perform properly, check the following:

24. Check the cable and fittings. The cable ends should fill or extend slightly beyond the crimped section of the fittings. If this is not the case, replace the cable.

25. Check the cable guide for damage. The cable groove should be parallel to the shoe web, and the body of the guide should lie flat against the web. Replace the cable guide if this is not so.

26. Check the pivot hook on the lever. The hook surfaces should be square with the body on the lever for proper pivoting. Repair or replace the hook as necessary.

27. Make sure that the adjusting screw starwheel is properly seated in the notch in the shoe web.

28. Install the brake drum and the wheel and tire assembly

29. Carefully lower the vehicle.

## ADJUSTMENTS

The drum brakes are self-adjusting and require a manual adjustment only after the brake shoes have been replaced, or when the length of the adjusting screw has been changed while performing some other service operation, as, for example, when taking off brake drums.

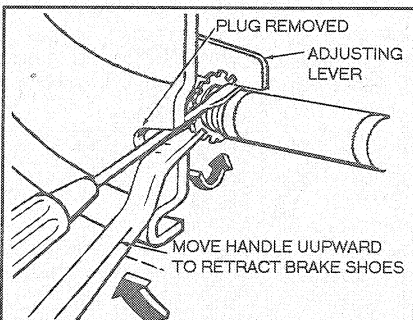
To adjust the brakes, perform the procedures that follow:

### Drum Installed

▶ See Figure 60

1. Raise and support the rear of the vehicle on jackstands.

2. Remove the rubber plug from the adjusting slot on the backing plate.



84929004

Fig. 60 Rear brake shoe adjustment

## \*\*\* CAUTION

**Brake shoes may contain asbestos, which has been determined to be a cancer causing agent. Never clean the brake surfaces with compressed air! Avoid inhaling any dust from any brake surface! When cleaning brake surfaces, use a commercially available brake cleaning fluid.**

3. Insert a brake adjusting spoon into the slot and engage the lowest possible tooth on the starwheel. Move the end of the brake spoon downward to move the starwheel upward and expand the adjusting screw. Repeat this operation until the brakes lock the wheels.

4. Insert a small screwdriver or piece of firm wire (coat hanger wire) into the adjusting slot and push the automatic adjusting lever out and free of the starwheel on the adjusting screw and hold it there.

5. Engage the topmost tooth possible on the starwheel with the brake adjusting spoon. Move the end of the adjusting spoon upward to move the adjusting screw starwheel downward and contact the adjusting screw. Back off the adjusting screw starwheel until the wheel spins freely with a minimum of drag. Keep track of the number of turns that the starwheel is backed off, or the number of strokes taken with the brake adjusting spoon.

6. Repeat this operation for the other side. When backing off the brakes on the other side, the starwheel adjuster must be backed off the same number of turns to prevent side-to-side brake pull.

7. Remove the jackstands and lower the vehicle.

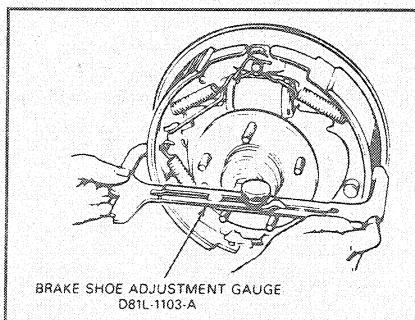
8. After the brakes are adjusted make several stops while backing the vehicle up, to equalize the brakes at both of the wheels. Road test the vehicle.

### Drum Removed

▶ See Figures 61 and 62

## \*\*\* CAUTION

**Brake shoes may contain asbestos, which has been determined to be a cancer causing agent. Never clean the brake surfaces with compressed air! Avoid inhaling any dust from any brake surface! When cleaning brake surfaces, use a commercially available brake cleaning fluid.**



84929002

Fig. 61 Use a gauge as shown to measure the brake shoes

1. Make sure that the shoe-to-contact pad areas are clean and properly lubricated.

2. Using an inside caliper check the inside diameter of the drum. Measure across the diameter of the assembled brake shoes, at their widest point.

3. Turn the adjusting screw so that the diameter of the shoes is 0.030 in. (0.76mm) less than the brake drum inner diameter.

4. Install the drum.

## Wheel Cylinders

### INSPECTION

Carefully pull the lower edges of the wheel cylinder boots away from the cylinders to see if the interior of the cylinder is wet with brake fluid. Excessive fluid at this point indicates leakage past the piston cups and a need for wheel cylinder replacement.

▶ A slight amount of fluid is nearly always present and acts as a lubricant for the piston.

### REMOVAL & INSTALLATION

▶ See Figures 63, 64, 65 and 66

1. Raise and safely support the vehicle.
2. Remove the rear wheel and tire assembly.
3. Remove the brake drum retainers, if equipped.
4. Grasp the brake drum and remove.
5. If the drum will not slide off with light force, then the brake shoes need to be backed off.

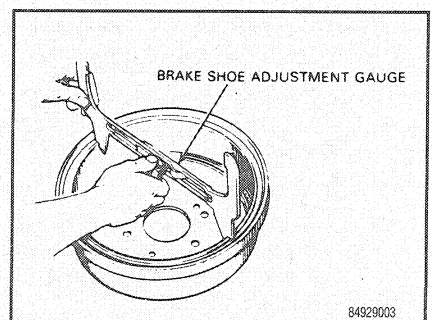
## \*\*\* CAUTION

**Brake shoes may contain asbestos, which has been determined to be a cancer causing agent. Never clean the brake surfaces with compressed air! Avoid inhaling any dust from any brake surface! When cleaning brake surfaces, use a commercially available brake cleaning fluid.**

6. Remove the brake drum.
7. Remove the brake shoes.

## \*\*\* CAUTION

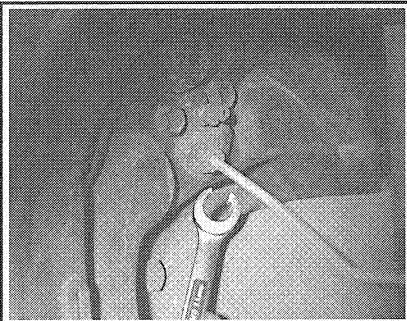
**Brake fluid contains polyglycol ethers and polyglycols. Avoid contact with the eyes and wash your hands thoroughly after handling brake fluid. If you do get brake fluid in your**



84929003

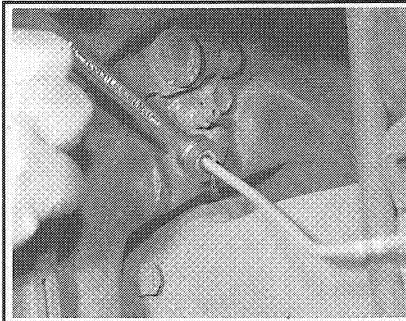
Fig. 62 Use a gauge as shown to measure the drum





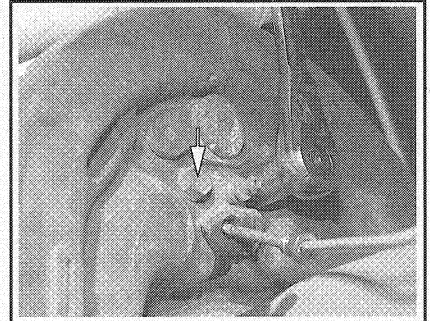
91199P23

**Fig. 63** Use a suitable size flare nut wrench to . . .



91199P24

**Fig. 64** . . . loosen the brake line fitting on the wheel cylinder



91199P25

**Fig. 65** Remove the wheel cylinder retaining bolts and . . .



91199P26

**Fig. 66** . . . remove the wheel cylinder from the backing plate

**eyes, flush your eyes with clean, running water for 15 minutes. If eye irritation persists, or if you have taken brake fluid internally, IMMEDIATELY seek medical assistance.**

8. Disconnect the brake line at the wheel cylinder.

9. Remove the 2 bolts securing the wheel cylinder to the backing plate and remove the wheel cylinder.

**To install:**

10. Reinstall the wheel cylinder to the brake backing plate and install the 2 retaining bolts. Torque the retaining bolts to 84–108 inch. lbs. (10–13 Nm).

11. Reconnect the brake line to the wheel cylinder and torque the fitting to 10–18 ft. lbs. (14–24 Nm).

12. Lubricate the rear brake shoe contact points on the backing plate with an appropriate grease.

13. Install the brake shoes.

14. Make sure that the brake drum and brake shoes are clean of any oils or protective coatings.

15. Reinstall the brake drum.

16. Bleed the brake system of air until a firm pedal is achieved. Top off the brake fluid in the master cylinder.

**\*\*\* WARNING**

**Clean, high quality brake fluid is essential to the safe and proper operation of the brake system. You should always buy the highest quality brake fluid that is available. If the brake fluid becomes contaminated, drain and flush the system, then refill the master cylinder with new fluid. Never reuse any brake fluid. Any brake fluid that is removed from the system should be discarded. Also, do not allow any brake fluid to come in contact with a painted surface; it will damage the paint.**

17. Reinstall the wheel and tire assembly.

18. Lower the vehicle.

19. Pump the brake pedal several times to assure a good pedal.

20. Road test the vehicle and check the brake system for proper operation.

## PARKING BRAKE

### Brake Shoes (Parking)

#### REMOVAL & INSTALLATION

♦ See Figures 67 and 68

1. Raise and safely support the vehicle.
2. Remove the rear axle shaft; refer to Section 7.
3. Disconnect the brake cable from the lever.
4. Remove the brake shoe retaining springs and pins.
5. Set the adjuster assembly to the shortest length. Pull the shoes away from the backing plate slightly and spread them enough to remove the adjuster assembly.
6. Remove the upper return (adjuster) spring.
7. Lift the shoes over the support and remove the shoes and actuating lever as an assembly. Make sure the lever does not damage the boot or pull the boot out of position.
8. Disassemble the shoes, lever and springs.

**To install:**

9. Install the lower return springs and actuating lever to the brake shoes.

10. Make sure the boot is properly positioned in the backing plate. Install the shoes by first inserting the lever through the boot, then lowering the shoes into position.

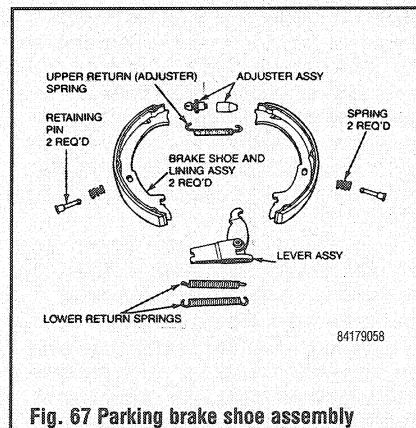
11. Install the upper return (adjuster) spring and install the adjuster assembly.

12. Install the brake shoe retaining springs and pins.

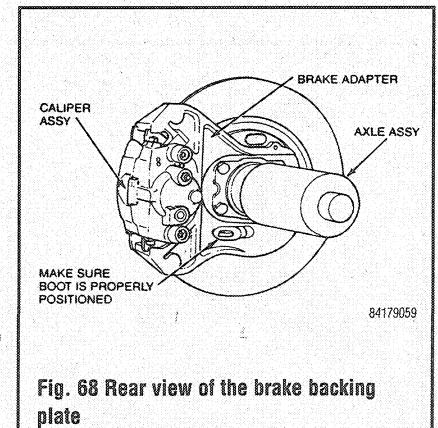
13. Connect the brake cable to the lever.

14. Install the rear axle shaft.

15. Center the brake shoes on the backing plate. Using an 8-in. micrometer or calipers, gauge the brake shoes.



**Fig. 67** Parking brake shoe assembly



**Fig. 68** Rear view of the brake backing plate

## ANTI-LOCK BRAKE SYSTEM

### General Information

The 4-Wheel Anti-lock Brake System (ABS) is an electronically operated, all wheel brake control system. Major components include the power brake booster, master cylinder, the wheel speed sensors, and the Hydraulic Control Unit (HCU) which contains the control module, a relay, and the pressure control valves.

The system is designed to retard wheel lockup during periods of high wheel slip when braking. Retarding wheel lockup is accomplished by modulating fluid pressure to the wheel brake units. When the control module detects a variation in voltage across the wheel speed sensors, the ABS is activated. The control module opens and closes various valves located inside the HCU. These valves, called dump and isolation valves, modulate the hydraulic pressure to the wheels by applying and venting the pressure to the brake fluid circuits.

Some models are equipped with a Traction Assist (TA) system. The TA system senses wheel spin upon acceleration, turns on the Hydraulic Control Unit (HCU) pump and applies fluid pressure to the appropriate rear wheel. Two additional isolation valves in the HCU will also close to permit fluid to flow only to the rear wheels.

The TA system monitors TA usage to avoid overheating the rear brakes. If the system does sense brake overheating, the ABS module will inhibit TA operation until the rear brakes are permitted to cool down.

### SYSTEM COMPONENTS

The anti-lock brake system consists of the following components:

- Vacuum booster and master cylinder assembly
- Hydraulic Control Unit (HCU)
- ABS module
- Wheel sensors
- Pedal travel switch

### ABS Module

See Figures 69, 70 and 71

The ABS module is an on-board, self-test, non-repairable unit consisting of 2 microprocessors and

SERVICE CODE (COMPONENT)	
11	(Electronic Controller)
12	(Electronic Controller-Replacer)
21	(Main Valve)
22	(LH Front Inlet Valve)
23	(LH Front Outlet Valve)
24	(RH Front Inlet Valve)
25	(RH Front Outlet Valve)
26	(Rear Inlet Valve)
27	(Rear Outlet Valve and Ground)
31	(LH Front Sensor)
32	(RH Front Sensor)
33	(RH Rear Sensor)
34	(LH Rear Sensor)
35	(LH Front Sensor)
36	(RH Front Sensor)
37	(RH Rear Sensor)
38	(LH Rear Sensor)
41	(LH Front Sensor)
42	(RH Front Sensor)
43	(RH Rear Sensor)

93149G01

Fig. 70 The on-board self test service codes (1 of 2)

SERVICE CODE (COMPONENT)	
44	(LH Rear Sensor)
45	(LH Front Sensor)
46	(RH Front Sensor)
47	(RH and LH Rear Sensors)
48	(Any 3 Sensors missing)
51	(LH Front Outlet Valve)
52	(RH Front Outlet Valve)
53	(Rear Outlet Valve)
54	(Rear Outlet Valve)
55	(LH Front Sensor)
56	(RH Front Sensor)
57	(RH Rear Sensor)
58	(LH Rear Sensor)
61	(FL and PWS Circuit)
71	(LH Front Sensor)
72	(RH Front Sensor)
73	(RH Rear Sensor)
74	(LH Rear Sensor)
75	(LH Front Sensor)
76	(RH Front Sensor)
77	(RH Rear Sensor)
78	(LH Rear Sensor)
86	(Electronic Controller)
89	(Electronic Controller)

93149G02

Fig. 71 The on-board self test service codes (2 of 2)

the necessary circuitry for their operation. These microprocessors are programmed identically. The ABS module monitors system operation during normal driving as well as during anti-lock braking and traction assist cycling.

Under normal driving conditions, the microprocessors produce short test pulses to the solenoid valves that check the electrical system without any mechanical reaction. Impending wheel lock conditions trigger signals from the ABS module that open and close the appropriate solenoid valves. This results in moderate pulsation in the brake pedal. If brake pedal travel exceeds a preset dimension determined by the pedal travel switch setting, the ABS module will send a signal to the pump to turn on and provide high pressure to the brake system. When the pump starts to run, a gradual rise in pedal height will be noticed. This rise will continue until the pedal travel switch closes and the pump will shut off until the pedal travel exceeds the travel switch setting again. During normal braking, the brake pedal feel will be identical to a standard brake system.

During traction assist operation, the ABS module will close the appropriate isolation valves and operate the pump. If the brakes are applied during cycling, the system will automatically shut off. The ABS module monitors traction assist usage and will shut off the traction assist features to prevent overheating of the rear brakes. If the system shuts off, there is a cool down period required before it becomes functional again. This cool down period

varies depending on brake usage during the cool down period. Anti-lock braking is still fully functional during the cool down period.

Most malfunctions, which occur to the anti-lock brake system and the traction assist, will be stored as a coded number in the keep-alive memory of the ABS module. The codes can be retrieved from memory by following the on-board self-test procedures.

Any brake code between 20-29 must be serviced before the processor will output any other codes

### REMOVAL & INSTALLATION

#### 1988-94 Continental and Mark VII

See Figures 72, 73 and 74

#### 1990-94 Town Car and 1993-94 Mark VIII

See Figure 75

1. Disconnect the negative battery cable.
2. Locate the ABS module at the left front side of the radiator support.
3. Detach the 55-pin connector from the ABS module. Unlock the connector by pulling up the lever completely. Move the end of the connector away from the ABS module until all terminals are clear, then pull the connector up and out of the slots in the ABS module.
4. Remove the 3 screws attaching the ABS



Fig. 72 This is the ABS module. It is located in the luggage compartment, mounted against the rear seat supports

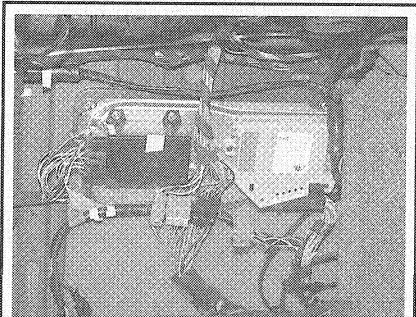


Fig. 73 You will find the ABS module mounted next to the door lock module

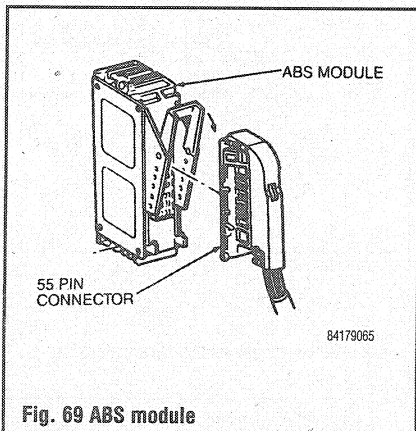
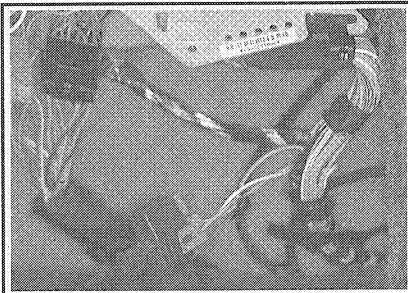


Fig. 69 ABS module





93149P03

**Fig. 74** This is the test connector for the ABS system. Use the Ford Super Star II tester or an equivalent scan tool to access the ABS system

module to the mounting bracket and remove the ABS module.

**To install:**

5. Align the ABS module with the bracket so that the lever is facing the drivers side of the vehicle. If all 3 mounting holes in the ABS module do not line up with the holes in the mounting bracket, the ABS module is incorrectly aligned with the bracket. Install the 3 attaching screws and tighten to 40–60 inch lbs. (4.5–6.8 Nm).

6. Attach the 55-pin connector by installing the bottom part of the connector into the slots in the ABS module and pushing the top portion of the connector into the ABS module. Then, pull the locking lever completely down to ensure proper installation.

7. Connect the negative battery cable.

**1995–00 Vehicles**

➔ **The control module is located on the HCU. To facilitate the removal of the module, the HCU must be removed. If the proper tools for bleeding the ABS system are not available, you will need to have a professional technician perform this repair.**

**\*\*\* WARNING**

**Electronic modules are sensitive to static electrical charges. If exposed to these charges, damage may result.**

1. Disconnect the negative battery cable.
2. Remove the HCU as describe din this section.
3. Remove the module retaining screws and remove the anti-lock brake control module.
4. The installation is the reverse of the removal.

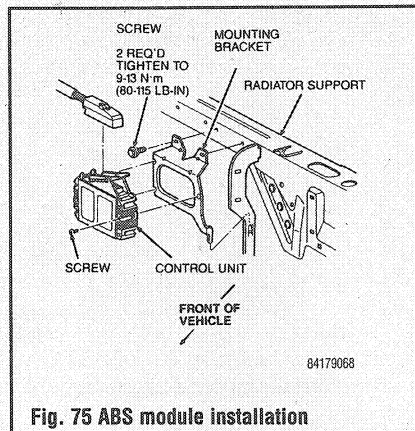
**Hydraulic Control Unit**

**REMOVAL & INSTALLATION**

**1992–94**

➔ **See Figure 76**

1. Disconnect the negative battery cable and remove the air cleaner and air outlet tube.
2. Detach the 19-pin connector from the HCU



**Fig. 75** ABS module installation

to the wire harness and detach the 4-pin connector from the HCU to the pump motor relay.

3. Remove the 2 lines from the inlet ports and the 4 lines from the outlet ports of the HCU. Plug each port to prevent brake fluid from spilling onto the paint and wiring.

4. Remove the 3 nuts retaining the HCU assembly to the mounting bracket and remove the assembly from the vehicle.

➔ **The nut on the front of the HCU also retains the relay-mounting bracket.**

**To install:**

5. Position the HCU assembly into the mounting bracket. Install the 3 retaining nuts and tighten to 12–18 ft. lbs. (16–24 Nm). Make sure the ABS pump motor relay bracket is retained by the front bracket nut.

6. Connect 4 lines to the outlet ports on the side of the HCU and 2 lines to the inlet ports on the rear of the HCU and tighten the fittings to 10–18 ft. lbs. (14–24 Nm).

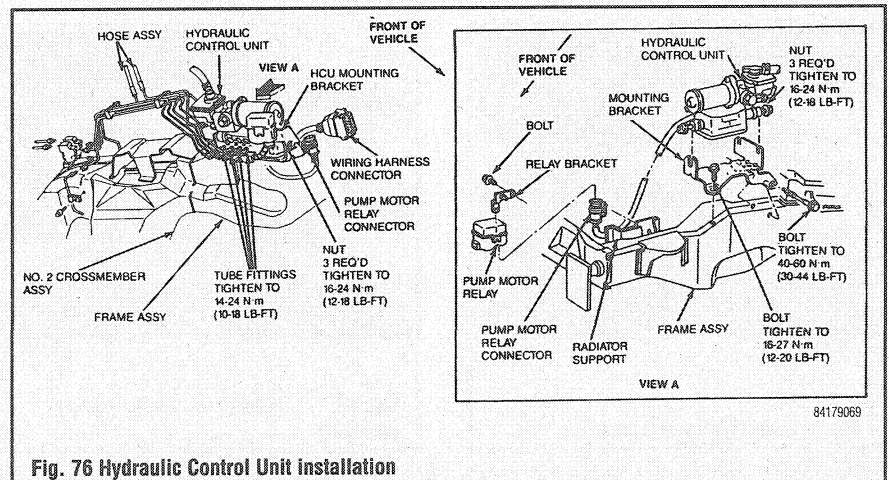
7. Attach the 19-pin connector to the harness and the 4-pin connector to the pump motor relay.

8. Install the air cleaner and air outlet tube.

9. Connect the battery cables, properly bleed the brake system and check for fluid leaks.

**1995–00**

1. Disconnect the negative battery cable.
2. Detach the anti-lock brake control module electrical connectors.



**Fig. 76** Hydraulic Control Unit installation

**\*\*\* CAUTION**

**Brake fluid contains polyglycol ethers and polyglycols. Avoid contact with the eyes and wash your hands thoroughly after handling brake fluid. If you do get brake fluid in your eyes, flush your eyes with clean, running water for 15 minutes. If eye irritation persists, or if you have taken brake fluid internally, IMMEDIATELY seek medical assistance.**

3. Disconnect and plug the hydraulic brake lines.

4. Remove the HCU retaining bolts and remove the HCU.

5. If necessary, remove the HCU bracket.

**To install:**

6. If removed, install the HCU bracket.

7. Position the HCU.

8. Install and tighten the retaining bolts.

9. Connect the hydraulic brake lines.

10. Connect the anti-lock brake control module electrical connectors.

11. Connect the negative battery cable.

12. Bleed the 4-wheel ABS.

**Speed Sensors**

**REMOVAL & INSTALLATION**

**Front**

➔ **See Figures 77, 78, 79, 80 and 81**

1. Disconnect the negative battery cable.

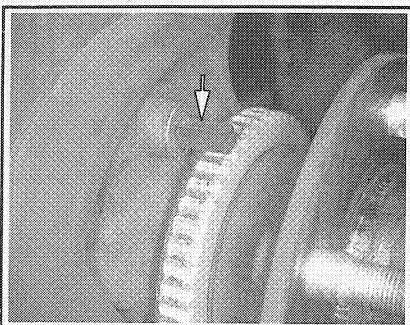
2. From inside engine compartment, detach sensor assembly 2-pin connector from the wiring harness.

3. Remove the steel routing clip attaching the sensor wire to the tube bundle on the left sensor or remove the plastic routing clip attaching the sensor wire to the frame on the right sensor.

4. Remove the rubber coated spring steel clip holding the sensor wire to the frame.

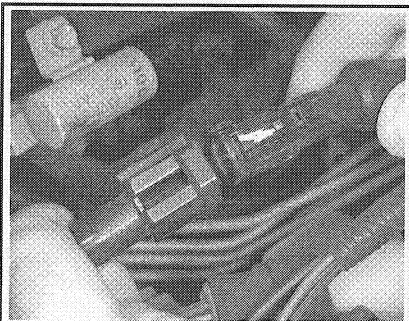
5. Remove the sensor wire from the steel routing clip on the frame and from the dust shield.

6. Remove the sensor attaching bolt from the front spindle and slide the sensor out of the mounting hole.



89609P51

**Fig. 77** The speed sensor sits directly over the exciter ring in the front knuckle



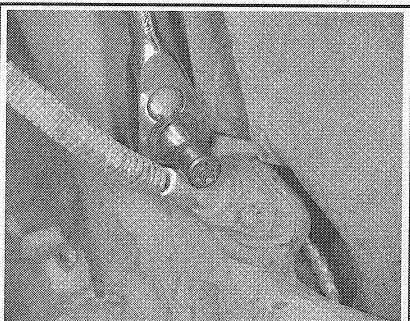
89609P55

**Fig. 78** Detach the speed sensor connector in the engine compartment



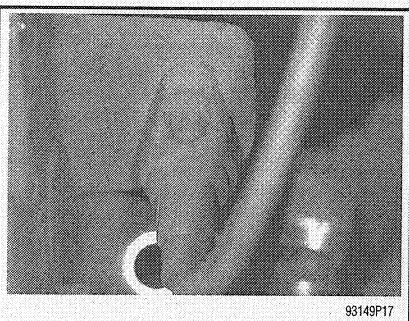
89609P53

**Fig. 79** Remove the speed sensor harness from the routing clips



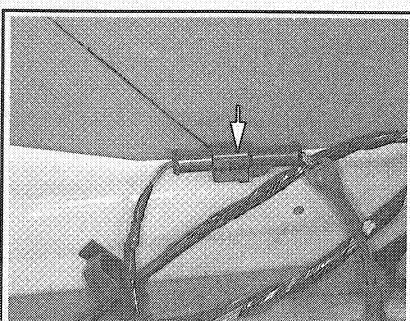
89609P52

**Fig. 80** A special E6 Torx® socket is required to remove the speed sensor-retaining bolt



93149P17

**Fig. 81** The sensor sits in a special mounting boss that does not allow an adjustable air gap between the sensor and exciter ring



89609P04

**Fig. 82** Detach the speed sensor connector in the luggage compartment

### To install:

7. Install the sensor into the mounting hole in the front spindle and attach with the mounting bolt. Torque to 40–60 inch lbs. (4.5–6.8 Nm).
8. Insert the sensor routing grommets into the dust shield and steel bracket on the frame. Route the wire into the engine compartment.
9. Install the rubber coated steel clip that holds the sensor wire to the frame into the hole in the frame.
10. Install the steel clip that holds sensor wire to tube bundle on left side or plastic clip that holds sensor to frame on right side.
11. Reconnect the 2-pin connector to wire harness. Reconnect the negative battery cable.

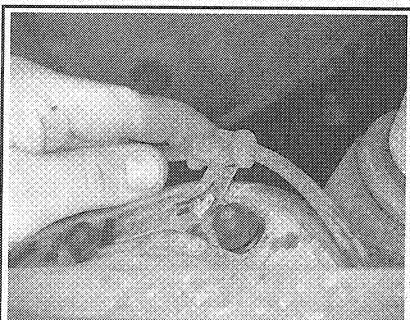
### Rear

#### ♦ See Figures 82 thru 88

1. Disconnect the negative battery cable.
2. From inside luggage compartment, detach 2-pin sensor connector from wiring harness and push sensor wire through hole in floor.
3. From below vehicle, remove sensor wire from routing bracket located on top of rear axle carrier housing and remove steel clip holding sensor wire and brake tube against axle housing.
4. Remove screw from clip holding sensor wire and brake tube to bracket on axle.
5. Remove sensor to rear adapter retaining bolt and remove sensor.

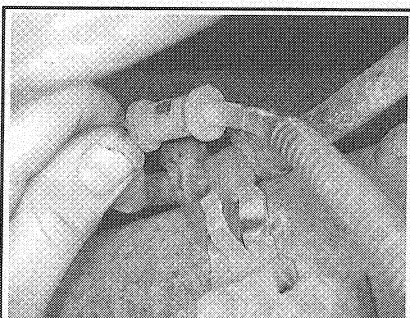
### To install:

6. Insert sensor adapter and install retaining bolt. Torque to 40–60 inch lbs. (4.5–6.8 Nm).
7. Attach clip holding sensor and brake tube to bracket on axle housing and secure with screw. Torque to 40–60 inch lbs. (4.5–6.8 Nm).
8. Install steel clip around axle tube that holds sensor wire and brake tube against axle tube and push spool-shaped grommet into clip located on top of axle carrier housing.
9. Push sensor wire connector up through hole in floor and seat large round grommet into hole.
10. Push sensor wire connector up through hole in floor and seat large round grommet into hole.



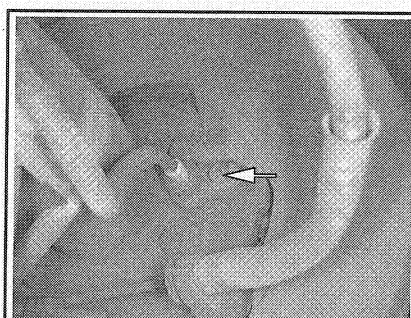
89609P37

**Fig. 83** Grasp the harness and . . .



89609P36

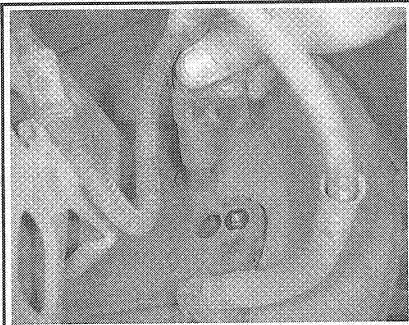
**Fig. 84** . . . remove it from the routing brackets



89609P32

**Fig. 85** The rear speed sensor is mounted on the back of the hub assembly





**Fig. 86** Remove the sensor retaining bolt and remove the sensor from the hub

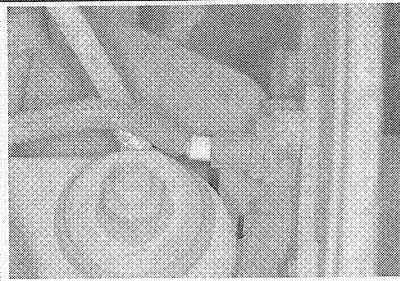
11. Reconnect sensor 2-pin connector to wiring harness inside luggage compartment.

## Bleeding the ABS System

1992-1994

➔The ABS brake system must be bled using Anti-lock Test Adapter T90P-50-ALA, or equivalent. If the procedure is not followed correctly, air will stay trapped in the Hydraulic Control Unit (HCU) which will lead to a spongy brake pedal.

1. To bleed the master cylinder and the HCU, connect the anti-lock tester wiring harness to the 55-pin harness connector of the ABS module.
2. Place the bleed/harness switch in the bleed position.
3. Turn the ignition switch to the ON position.
4. Push the motor button on the tester down, starting the pump motor. The pump motor will run for 60 seconds.
5. After 20 seconds of pump motor operation, push and hold the valve button down. Hold the valve button down for 20 seconds.



**Fig. 87** The sensor is bolted through the back of the plate on the rear wheels, and is held in place by an external Torx® head bolt. The same as the front

6. The pump motor will continue to run for an additional 20 seconds.

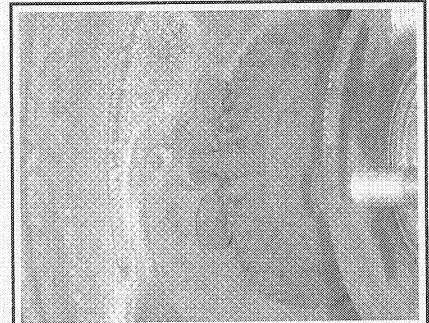
7. The master cylinder and HCU should be free of air and the brake lines must now be bleed using the conventional method for non-ABS brake systems by bleeding the wheels in the following sequence: right-hand rear, left-hand front, left-hand rear and right-hand front.

8. Road test the vehicle and check for proper brake system operation.

1995-00

Whenever service is performed on the ABS valve block or pump and motor assembly, the following procedure must be performed to make sure no air is trapped in the ABS control and modulator assembly. If this procedure is not done, the vehicle operator could experience a spongy pedal after the ABS is actuated. This procedure requires the use of the Ford New Generation STAR (NGS) Tester, or equivalent.

1. First bleed the entire brake system conventionally as described above.
2. Reattach the NGS Tester to the data link connector as though retrieving codes.



**Fig. 88** When the head comes through the backing plate it mounts next to the exciter ring

3. Make sure the ignition is in the **RUN** position.

4. Follow the instructions on the NGS screen. Choose the correct vehicle and model year, go to DIAGNOSTIC DATA LINK menu item, choose ABS MODULE, choose FUNCTION TESTS and choose SERVICE BLEED.

5. The NGS will prompt you to depress the brake pedal. Make sure you press hard on the brake pedal, and hold it down for approximately 5 seconds while the NGS opens the outlet valves in the brake pressure control valve block. When the outlet valves are opened, you should immediately feel the pedal drop. It is very important that you continue pushing the pedal all the way to the floor. The NGS will then instruct you to release the brake pedal. After you release the brake pedal, the NGS will run the ABS hydraulic pump motor for approximately 15 seconds.

6. Repeat the previous step to ensure that all air is bleed from the ABS unit. Upon completion, the NGS will display SERVICE BLEED PROCEDURE COMPLETED.

7. Repeat the conventional bleeding procedure.
8. Once complete, road test the vehicle and check for proper brake system operation.

**BRAKE SPECIFICATIONS**  
All measurements in inches unless noted

Year	Model	Master Cylinder Bore	Front Brake Disc			Rear Brake Disc			Minimum Lining Thickness	Brake Caliper	
			Original Thickness	Minimum Thickness	Maximum Run-out	Original Thicknes	Minimum Thickness	Maximum Run-out		Bracket Bolts (ft. lbs.)	Mounting Bolts (ft. lbs.)
1988	Mark VII	N/A	1.024	0.972	0.003	N/A	0.895	0.004	0.123	125-169	21-26
	Contintental	N/A	1.024	0.970	0.002	N/A	0.974 A	0.002	0.123	125-169	21-26
	Town Car E	1.000	1.024	0.972	0.003	10.00 B	10.90 C	0.005	0.030 D	125-169	21-26
1989	Mark VII	N/A	1.024	0.972	0.003	N/A	0.895	0.004	0.123	125-169	21-26
	Contintental	N/A	1.024	0.970	0.002	N/A	0.974 A	0.035	0.123	125-169	21-26
	Town Car E	1.000	1.024	0.972	0.003	10.00 B	10.90 C	0.005	0.030 D	125-169	21-26
1990	Mark VII	N/A	1.024	0.972	0.003	N/A	0.895	0.004	0.123	125-169	21-26
	Contintental	N/A	1.024	0.970	0.002	N/A	0.974 A	0.035	0.123	125-169	21-26
	Town Car E	1.000	1.024	0.972	0.003	10.00 B	10.90 C	0.005	0.030 D	125-169	21-26
1991	Mark VII	1.000	1.024	0.974	0.002	0.550	0.510	0.002	0.123	125-169	21-26
	Contintental	1.000	1.024	0.974	0.002	9.400	0.510	0.035	0.123	125-169	21-26
	Town Car	1.000	1.024	0.974	0.002	0.550	0.510	0.002	0.125	125-169	21-26
1992	Mark VII	1.000	1.024	0.974	0.002	0.550	0.510	0.002	0.123	125-169	21-26
	Contintental	1.000	1.024	0.974	0.002	0.550	0.510	0.035	0.123	125-169	21-26
	Town Car	1.000	1.024	0.974	0.002	0.550	0.510	0.002	0.125	125-169	21-26
1993	Mark VIII	1.000	1.024	0.974	0.002	0.550	0.510	0.002	0.123	125-169	21-26
	Contintental	1.000	1.024	0.974	0.002	0.550	0.510	0.035	0.123	125-169	21-26
	Town Car	1.000	1.024	0.974	0.002	0.550	0.510	0.002	0.125	125-169	21-26
1994	Mark VIII	1.000	1.024	0.974	0.002	0.550	0.510	0.002	0.123	125-169	21-26
	Contintental	1.000	1.024	0.974	0.002	0.550	0.502	0.035	0.123	125-169	21-26
	Town Car	1.000	1.024	0.974	0.002	0.550	0.510	0.002	0.125	125-169	21-26
1995	Mark VIII	1.000	1.024	0.974	0.002	0.550	0.510	0.002	0.123	125-169	21-26
	Contintental	1.000	1.024	0.974	0.002	0.550	0.502	0.035	0.123	125-169	21-26
	Town Car	1.000	1.024	0.974	0.002	0.550	0.510	0.002	0.125	125-169	21-26
1996	Mark VIII	1.000	1.024	0.974	0.002	0.550	0.510	0.002	0.123	125-169	21-26
	Contintental	1.000	1.024	0.974	0.002	0.550	0.502	0.035	0.123	125-169	21-26
	Town Car	1.000	1.024	0.974	0.002	0.550	0.510	0.002	0.125	125-169	21-26
1997	Mark VIII	1.000	1.024	0.974	0.002	0.550	0.510	0.002	0.123	125-169	21-26
	Contintental	1.000	1.024	0.974	0.002	0.550	0.502	0.035	0.123	125-169	21-26
	Town Car	1.000	1.024	0.974	0.002	0.550	0.510	0.002	0.125	125-169	21-26
1998	Mark VIII	1.000	1.024	0.974	0.002	0.550	0.510	0.002	0.123	125-169	21-26
	Contintental	1.000	1.024	0.974	0.002	0.550	0.502	0.035	0.123	125-169	21-26
	Town Car	1.000	1.024	0.974	0.002	0.550	0.510	0.002	0.125	125-169	21-26
1999	Contintental	1.000	1.024	0.974	0.002	0.550	0.502	0.035	0.123	125-169	21-26
	Town Car	1.000	1.024	0.974	0.002	0.550	0.510	0.002	0.125	125-169	21-26
2000	Contintental	1.000	1.024	0.974	0.002	0.550	0.502	0.035	0.123	125-169	21-26
	Town Car	1.000	1.024	0.974	0.002	0.550	0.510	0.002	0.125	125-169	21-26

NOTE: Follow specifications stamped on rotor or drum if figures differ from those in this chart.

A - Minimum safe thickness is shown on each rotor.

B - Original diameter for standard drum brake.

C - Maximum allowable diameter.

D - Rear Drum shoe measurement.

E - Rear drum brakes were standard on these vehicles.