

**BASIC FUEL SYSTEM**

**DIAGNOSIS 5-2**

**FUEL LINES AND FITTINGS 5-2**

HAIRPIN CLIP FITTING 5-2

REMOVAL & INSTALLATION 5-2

DUCKBILL CLIP FITTING 5-2

REMOVAL & INSTALLATION 5-2

SPRING LOCK COUPLING 5-2

REMOVAL & INSTALLATION 5-2

**GASOLINE FUEL INJECTION**

**SYSTEM 5-4**

GENERAL INFORMATION 5-4

FUEL SYSTEM SERVICE

PRECAUTIONS 5-5

RELIEVING FUEL SYSTEM

PRESSURE 5-5

FUEL PUMP 5-5

TESTING 5-5

REMOVAL & INSTALLATION 5-5

THROTTLE BODY 5-5

REMOVAL & INSTALLATION 5-5

FUEL RAIL AND FUEL INJECTOR(S) 5-7

REMOVAL & INSTALLATION 5-7

TESTING 5-9

FUEL PRESSURE REGULATOR 5-10

REMOVAL & INSTALLATION 5-10

PRESSURE RELIEF VALVE 5-11

REMOVAL & INSTALLATION 5-11

**FUEL TANK 5-11**

TANK ASSEMBLY 5-11

REMOVAL & INSTALLATION 5-11

ELECTRIC FUEL PUMP 5-11

REMOVAL & INSTALLATION 5-11

# 5

## FUEL SYSTEM

BASIC FUEL SYSTEM DIAGNOSIS 5-2

BASIC FUEL LINES AND FITTINGS 5-2

GASOLINE FUEL INJECTION

SYSTEM 5-4

FUEL TANK 5-11

# 5-2 FUEL SYSTEM

## BASIC FUEL SYSTEM DIAGNOSIS

When there is a problem starting or driving a vehicle, two of the most important checks involve the ignition and the fuel systems. The questions most mechanics attempt to answer first, "is there

spark?" and "is there fuel?" will often lead to solving most basic problems. For ignition system diagnosis and testing, please refer to the information on engine electrical components and ignition systems

found earlier in this manual. If the ignition system checks out (there is spark), then you must determine if the fuel system is operating properly (is there fuel?).

## FUEL LINES AND FITTINGS

➔ **Quick-connect (push type) fuel line fittings must be disconnected using proper procedure or the fitting may be damaged. There are two types of retainers used on the push connect fittings. Line sizes of 3/8 and 1/2 in. diameter use a hairpin clip retainer. The 1/4 in. diameter line connectors use a duck-bill clip retainer. In addition, some engines use spring-lock connections, secured by a garter spring, which require a special fuel line disconnect tool for removal.**

### \*\*\* CAUTION

Observe all applicable safety precautions when working around fuel. Whenever servicing the fuel system, always work in a well ventilated area. Do not allow fuel spray or vapors to come in contact with a spark or open flame. Keep a dry chemical fire extinguisher near the work area. Always keep fuel in a container specifically designed for fuel storage; also, always properly seal fuel containers to avoid the possibility of fire or explosion.

### Hairpin Clip Fitting

#### REMOVAL & INSTALLATION

➔ See Figures 1 and 2

1. Clean all dirt and grease from the fitting. Spread the two clip legs about 1/8 in. (3mm) each to disengage from the fitting and pull the clip outward from the fitting. Use finger pressure only; do not use any tools.

2. Grasp the fitting and hose assembly and pull away from the steel line. Twist the fitting and hose assembly slightly while pulling, if the assembly sticks.

3. Inspect the hairpin clip for damage, replacing the clip if necessary. Reinstall the clip in position on the fitting.

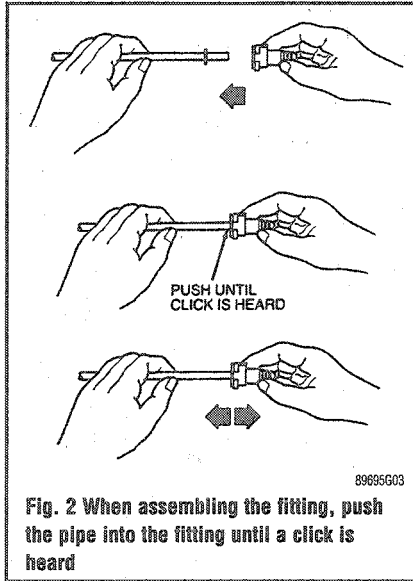
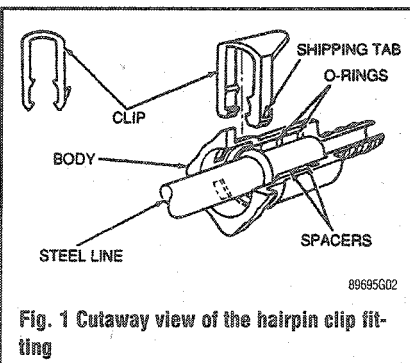

4. Inspect the fitting and inside of the connector to ensure freedom from dirt or obstruction. Install the fitting into the connector and push together. A click will be heard when the hairpin snaps into the proper connection. Pull on the line to insure full engagement.

### Duckbill Clip Fitting

#### REMOVAL & INSTALLATION

➔ See Figure 3

1. A special tool is available from Ford and other manufacturers for removing the retaining clips. Use Ford Tool T90T-9550-B or C or equivalent. If the tool is not on hand, go onto step 2. Align the slot on the push connector disconnect tool with

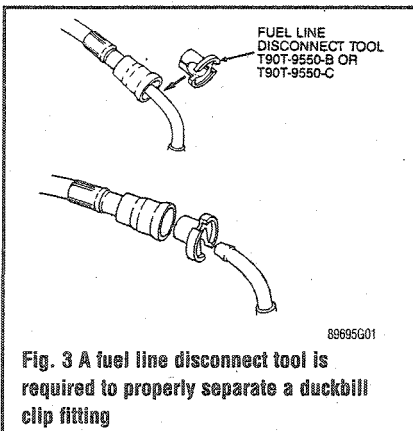

either tab on the retaining clip. Pull the line from the connector.

2. If the special clip tool is not available, use a pair of narrow 6-inch slip-jaw pliers with a jaw width of 0.2 in (5mm) or less. Align the jaws of the pliers with the openings of the fitting case and compress the part of the retaining clip that engages the case. Compressing the retaining clip will release the fitting, which may be pulled from the connector. Both sides of the clip must be compressed at the same time to disengage.

3. Inspect the retaining clip, fitting end and connector. Replace the clip if any damage is apparent.

4. Push the line into the steel connector until a click is heard, indicating the clip is in place. Pull on the line to check engagement.

### Spring Lock Coupling

#### REMOVAL & INSTALLATION

➔ See Figures 4 thru 14

The spring lock coupling is held together by a garter spring inside a circular cage. When the cou-

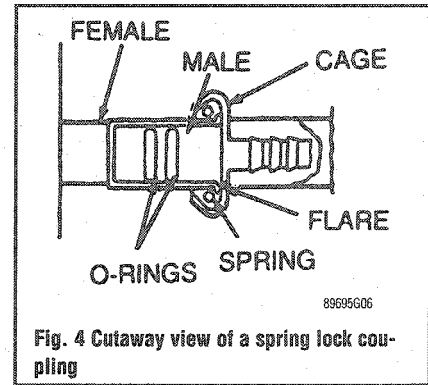

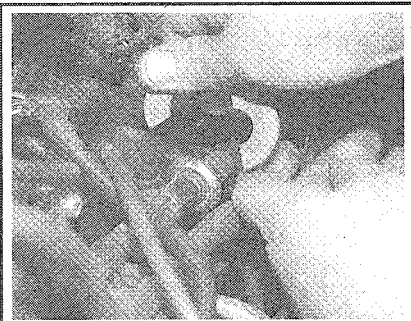

91055P23

**Fig. 6** This type of removal tool has a hinged center section that allows you to fit it around the fuel line

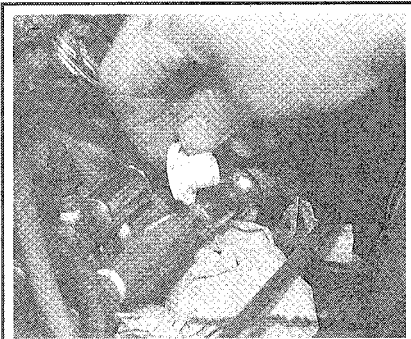

91055P25

**Fig. 9** This type of removal tool snaps over the line

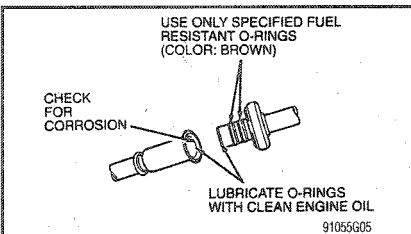

91055G05

**Fig. 12** The O-rings should be replaced if necessary with the specific ones used for the fuel system, a non-specific O-ring could leak

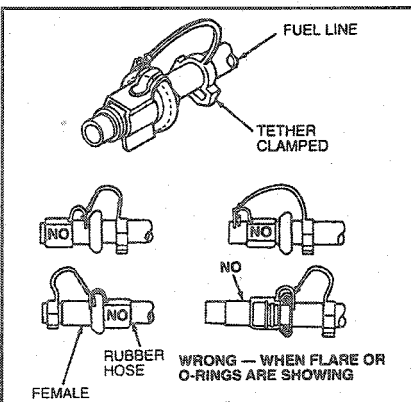

91055G07

**Fig. 13** The fitting should be inspected after assembly

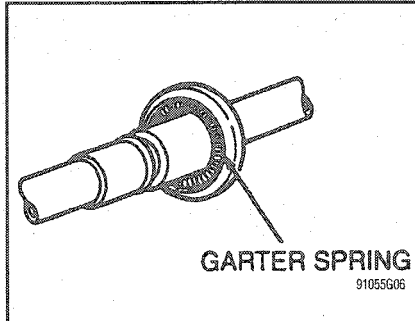

91055G06

**Fig. 7** The garter spring is located inside the fitting and holds the fitting together

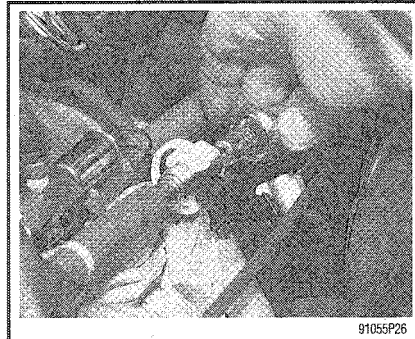

91055P26

**Fig. 10** Slide the tool back to unseat the garter spring on the fitting, and pull back on the fuel line to separate them

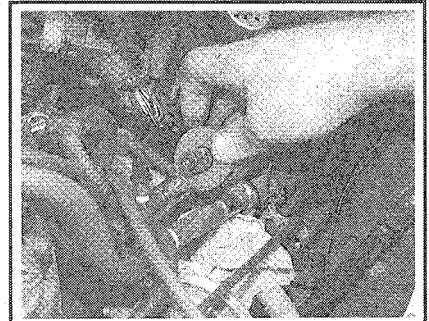

91055P24

**Fig. 8** Slide the tool back to unseat the garter spring on the fitting, and pull back on the fuel line to separate them

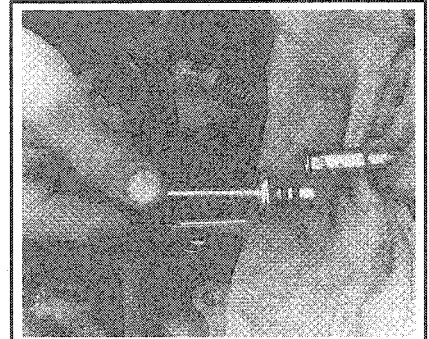

88155P48

**Fig. 11** Be sure to check the O-rings for damage; replace them if necessary

**TO DISCONNECT COUPLING**

CAUTION - RELIEVE FUEL PRESSURE BEFORE DISCONNECTING COUPLING

- REMOVE CLIP FROM COUPLING
- USE SPECIFIED TOOL OR EQUIVALENT

TOOL: D87L-9280A - 3/8 INCH D87L-9280B - 1/2 INCH

CAGE OPENING

FIT TOOL TO COUPLING SO THAT TOOL CAN ENTER CAGE OPENING TO RELEASE THE GARTER SPRING.
- PUSH TOOL INTO CAGE OPENING

NOTE: SPECIFIED TOOL WILL FIT AROUND RUBBER COVERED FUEL LINE

PUSH THE TOOL INTO THE CAGE OPENING TO RELEASE THE FEMALE FITTING FROM THE GARTER SPRING
- PULL THE COUPLING MALE AND FEMALE FITTINGS APART
- REMOVE THE TOOL FROM THE DISCONNECTED SPRING LOCK COUPLING

REPLACEMENT O-RINGS: 30084-586 (3/8 INCH DIA., 2 PER FITTING) 30047-596 (1/2 INCH DIA., 2 PER FITTING)

USE ONLY SPECIFIED FUEL RESISTANT O-RINGS (COLOR: BROWN)

CHECK FOR CORROSION

LUBRICATE O-RINGS WITH CLEAN ENGINE OIL

CLEAN FITTINGS WITH SOLVENT CHECK FOR MISSING OR DAMAGED O-RINGS. REPLACE MISSING O-RINGS. IF EITHER O-RING IS DAMAGED, REPLACE BOTH O-RINGS. REPLACE GARTER SPRINGS: 30-INCH - E1ZZ-9B579A 1/2-INCH - E1ZZ-9E578-B

FEMALE MALE CAGE O-RINGS FLARE SPRING

GARTER SPRING

TO ENSURE COUPLING ENGAGEMENT, PULL ON FITTING AND VISUALLY CHECK TO BE SURE GARTER SPRING IS OVER FLARED END OF FEMALE FITTING

FUEL LINE TETHER CLAMPED

YES

WRONG - WHEN FLARE OR O-RINGS ARE SHOWING

FEMALE RUBBER HOSE

**Fig. 14** Quick disconnect fitting procedures

84175046

# 5-4 FUEL SYSTEM

pling is connected together, the flared end of the female fitting slips behind the garter spring inside the cage of the male fitting. The garter spring and

cage then prevent the flared end of the female fitting from pulling out of the cage. As an additional locking feature, most vehicles have a horseshoe-shaped

retaining clip that improves the retaining reliability of the spring lock coupling.

## GASOLINE FUEL INJECTION SYSTEM

### General Information

◆ See Figures 15, 16, 17 and 18

The Electronic Fuel Injection (EFI) system was used 1988–94 3.8L engines. The EFI fuel system includes a high pressure (30–45 psi/209–310 kPa) tank-mounted electric fuel pump, throttle body, fuel charging manifold, pressure regulator, fuel filter, and both solid and flexible fuel lines. The fuel charging manifold includes six electronically controlled fuel injectors, each mounted directly above an intake port in the lower intake manifold. The Electronic Engine Control (EEC-IV) computer outputs a command to the fuel injectors to meter the appropriate quantity of fuel.

All vehicles with the 4.6L and 5.0L engines are equipped with a Sequential Electronic Fuel Injection (SEFI) system. In this system, fuel is metered into each intake port in sequence with the engine firing order, according to engine demand, through fuel injectors mounted on a tuned intake manifold. The SEFI system consists of two subsystems, the fuel

delivery system and the electronic control system. The fuel delivery system supplies fuel to the fuel injectors at a specified pressure. The electronic control system regulates the flow of fuel from the injectors into the engine.

The fuel delivery system consists of an electric fuel pump, fuel filters, fuel supply manifold (fuel rail), fuel pressure regulator and fuel injectors. The electric fuel pump, mounted in the fuel tank, draws fuel through a filter screen attached to the fuel pump/sending unit assembly. Fuel is pumped through a frame mounted fuel filter, to the engine compartment, and into the fuel supply manifold. The fuel supply manifold supplies fuel directly to the injectors. A constant fuel pressure to the injectors is maintained by the fuel pressure regulator. The fuel pressure regulator is mounted on the fuel supply manifold, downstream from the fuel injectors. The excess fuel supplied by the fuel pump but not required by the engine, passes through the regulator and returns to the fuel tank through the fuel return line. The fuel injectors spray a metered quantity of fuel into the intake air stream when they are

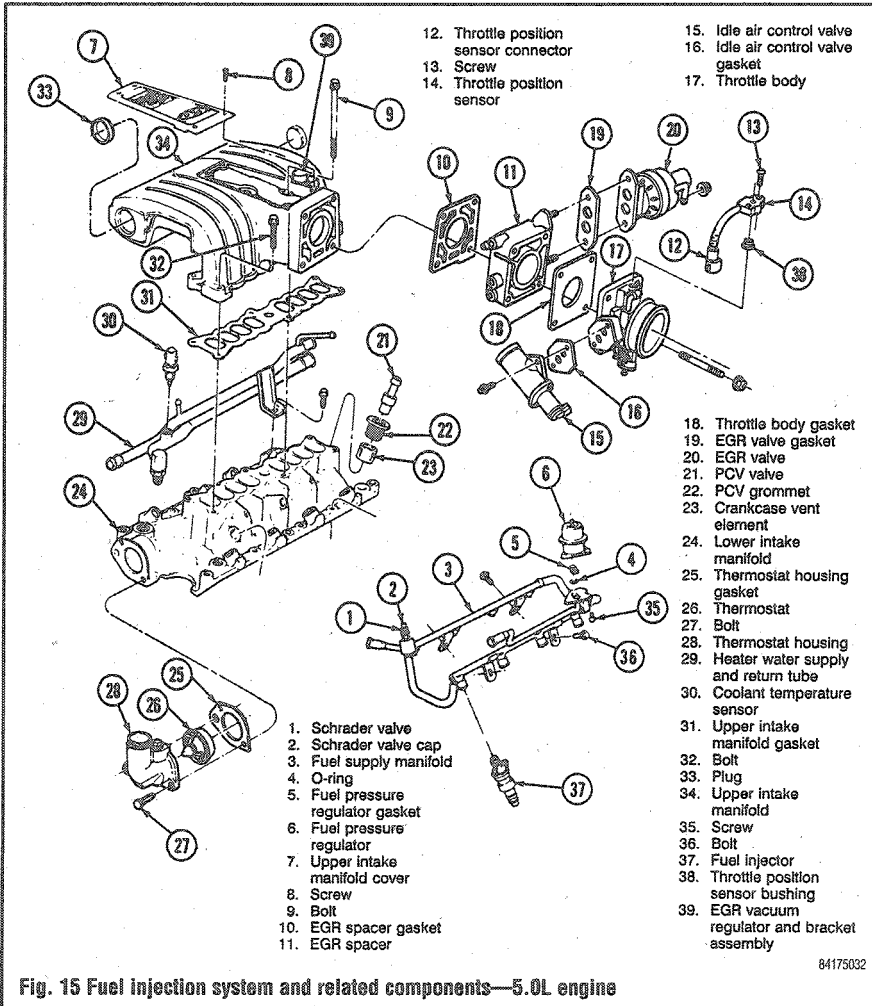

Fig. 15 Fuel injection system and related components—5.0L engine

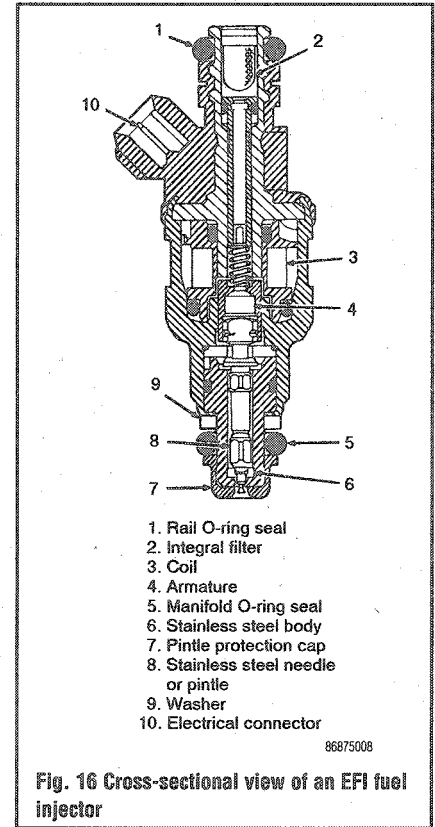

Fig. 16 Cross-sectional view of an EFI fuel injector

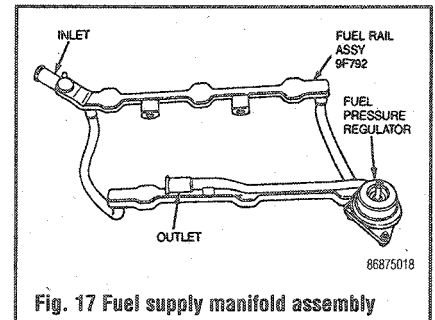

Fig. 17 Fuel supply manifold assembly

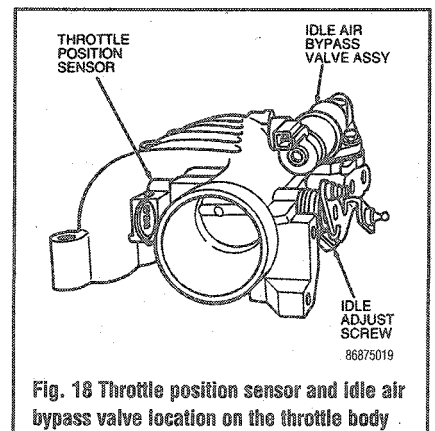

Fig. 18 Throttle position sensor and idle air bypass valve location on the throttle body

energized. The quantity of fuel is determined by the electronic control system.

Air entering the engine is monitored by speed, pressure and temperature sensors. The outputs of these sensors are processed by the Powertrain Control Module (PCM). The PCM computes the required fuel flow rate and determines the needed injector pulse width (injector "on" time) and sends a signal to the injector to meter the exact quantity of fuel. Each fuel injector is energized once every other crankshaft revolution, in sequence with the ignition firing order.

➔ For description and testing of electronic control system components, see Section 4.

## FUEL SYSTEM SERVICE PRECAUTIONS

Safety is the most important factor when performing not only fuel system maintenance, but any type of maintenance. Failure to conduct maintenance and repairs in a safe manner may result in serious personal injury or death. Work on a vehicle's fuel system components can be accomplished safely and effectively by adhering to the following rules and guidelines.

- To avoid the possibility of fire and personal injury, always disconnect the negative battery cable unless the repair or test procedure requires that battery voltage be applied.
- Always relieve the fuel system pressure prior to detaching any fuel system component (injector, fuel rail, pressure regulator, etc.) fitting or fuel line connection. Exercise extreme caution whenever relieving fuel system pressure to avoid exposing skin, face and eyes to fuel spray. Please be advised that fuel under pressure may penetrate the skin or any part of the body that it contacts.
- Always place a shop towel or cloth around the fitting or connection prior to loosening to absorb any excess fuel due to spillage. Ensure that all fuel spillage is quickly removed from engine surfaces. Ensure that all fuel-soaked cloths or towels are deposited into a flame-proof waste container with a lid.
- Always keep a dry chemical (Class B) fire extinguisher near the work area.
- Do not allow fuel spray or fuel vapors to come into contact with a spark or open flame.
- Always use a second wrench when loosening or tightening fuel line connections fittings. This will prevent unnecessary stress and torsion to fuel piping. Always follow the proper torque specifications.
- Always replace worn fuel fitting O-rings with new ones. Do not substitute fuel hose where rigid pipe is installed.

## Relieving Fuel System Pressure

### \*\* CAUTION

**Fuel supply lines on fuel injected vehicles will remain pressurized for some time after the engine is shut off. Fuel pressure must be relieved before servicing the fuel system.**

1. Disconnect the negative battery cable.
2. Remove the fuel tank cap to relieve the pressure in the fuel tank.

3. Remove the cap from the Schrader valve located on the fuel supply manifold.

4. Attach fuel pressure gauge T80L-9974-A or equivalent, to the Schrader valve and drain the fuel through the drain tube into a suitable container.

5. After the fuel system pressure is relieved, remove the fuel pressure gauge and install the cap on the Schrader valve.

## Fuel Pump

### TESTING

➔ See Figure 19

### \*\* CAUTION

**Observe all applicable safety precautions when working around fuel. Whenever servicing the fuel system, always work in a well ventilated area. Do not allow fuel spray or vapors to come in contact with a spark or open flame. Keep a dry chemical fire extinguisher near the work area. Always keep fuel in a container specifically designed for fuel storage; also, always properly seal fuel containers to avoid the possibility of fire or explosion.**

1. Check all hoses and lines for kinks and leaking. Repair as necessary.
2. Check all electrical connections for looseness and corrosion. Repair as necessary.
3. Turn the ignition key from the **OFF** position to the **RUN** position several times (do not start the engine) and verify that the pump runs briefly each time, (you will here a low humming sound from the fuel tank).

➔ Check that the inertia switch is reset before diagnosing power supply problems to the fuel pump.

The use of a scan tool is required to perform these tests.

4. Turn the ignition key **OFF**.
5. Connect a suitable fuel pressure gauge to the fuel test port (Schrader valve) on the fuel rail.
6. Connect the scan tool and turn the ignition key **ON** but do not start the engine.
7. Following the scan tool manufacturer's instructions, enter the output test mode and run the fuel pump to obtain the maximum fuel pressure.



89605P03

**Fig. 19 The fuel pressure test port is located on the fuel rail, under the protective cap**

8. The fuel pressure should be between 30–45 psi (210–310 kPa).

9. If the fuel pressure is within specification the pump is working properly. If not, continue with the test.

10. Check the pump ground connection and service as necessary.

11. Turn the ignition key **ON**.

12. Using the scan tool, enter output test mode and turn on the fuel pump circuit.

13. Using a Digital Volt Ohmmeter (DVOM), check for voltage (approximately 10.5 volts) at the fuel pump electrical connector.

14. If the pump is getting a good voltage supply, the ground connection is good and the fuel pressure is not within specification, then replace the pump.

## REMOVAL & INSTALLATION

See fuel pump under fuel tank in this section.

## Throttle Body

### REMOVAL & INSTALLATION

#### 3.8L Engine

#### UPPER INTAKE MANIFOLD AND THROTTLE BODY

➔ See Figure 20

1. Disconnect the negative battery cable.
2. Disengage the electrical connectors at the idle air bypass valve, throttle position sensor and the EGR position sensor.
3. Disconnect the throttle linkage at the throttle ball and transmission linkage from the throttle body. Remove the two retaining bolts securing the bracket to the intake manifold, then position the bracket with the cables out of the way.
4. Disengage the upper intake manifold vacuum fitting connections by disconnecting all of the vacuum lines to the vacuum tree, EGR valve and fuel pressure regulator.

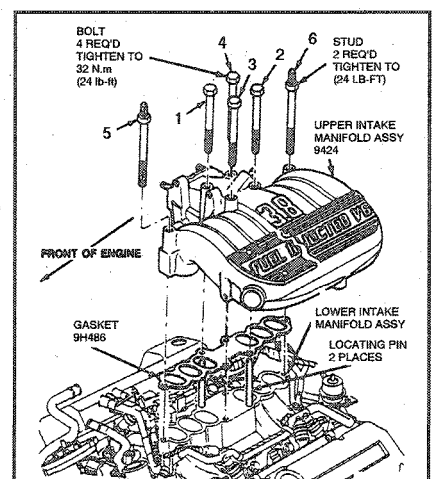

86675025

**Fig. 20 Upper intake manifold mounting—3.8L engine**

## 5-6 FUEL SYSTEM

5. Disconnect the PCV system by removing the hose from the fitting on the rear of the upper manifold.

6. Remove the nut retaining the EGR transducer to the upper intake manifold. Loosen the EGR tube at the exhaust manifold, then disconnect at the EGR valve.

7. Remove the two bolts retaining the EGR valve to the upper intake manifold, then remove the EGR valve and the EGR transducer as an assembly.

8. Remove the two canister purge lines from the fittings on the throttle body.

9. Remove the six upper intake manifold retaining bolts.

10. Remove the two retaining bolts on the front and rear edges of the upper intake manifold where the manifold support brackets are located.

11. Remove the nut retaining the alternator bracket to the upper intake manifold, then remove the two bolts retaining the alternator bracket to the water pump and alternator.

12. Remove the upper intake and throttle body as an assembly from the lower intake manifold.

### To install:

13. Clean and inspect the mating surfaces of the lower and upper intake manifold.

14. Position a new gasket on the lower intake manifold mounting surface. Using alignment studs will make the job easier.

15. Install the upper intake manifold and throttle body assembly to the lower intake manifold. If alignment studs are not used, make sure the gasket stays in place.

16. Install the four center retaining bolts and two studs to the upper manifold and tighten to 8 ft. lbs. (10 Nm). Repeat, in sequence, in two steps:

- a. Step 1: 15 ft. lbs. (20 Nm).
- b. Step 2: 24 ft. lbs. (32 Nm).

17. Install the two bolts retaining the manifold support brackets to the upper manifold, then tighten to 19 ft. lbs. (25 Nm).

18. Position the alternator bracket, then install the two retaining bolts to the water pump and alternator. Install the alternator bracket to the upper intake manifold retaining nut, then tighten to 19 ft. lbs. (26 Nm).

19. Connect the EGR valve to the EGR tube, making sure that the tube is properly seated in the EGR valve. Connect the EGR valve to the upper manifold, then tighten to 19 ft. lbs. (26 Nm).

20. Install the canister purge lines to the fittings on the throttle body.

21. Connect the PCV hose to the rear of the upper manifold.

22. Connect the vacuum lines to the vacuum tree, EGR valve, and fuel pressure regulator.

23. Position the throttle linkage bracket with cables to the upper intake manifold. Install the two retaining bolts, then tighten them to 13 ft. lbs. (17

Nm). Connect the throttle cable and the transaxle cable to the throttle body.

24. Engage the air bypass valve, TP sensor and EGR position sensor electrical connectors.

➔ **If the lower intake manifold was removed, fill and bleed the cooling system.**

### AIR INTAKE THROTTLE BODY

#### ▶ See Figure 21

1. Disconnect the negative battery cable.

2. Disengage the TP sensor and air bypass valve electrical connectors.

3. Remove the four throttle body retaining bolts. Remove the throttle body assembly, then remove and discard the gasket between the throttle body and the upper intake manifold.

4. If scraping is necessary, be careful not to damage the air bypass valve or throttle body gasket surfaces. Also, do not allow gasket material to drop into the throttle body.

### To install:

5. Install the throttle body using a new gasket on the four studs of the upper intake manifold. Tighten the retaining nuts to 19 ft. lbs. (26 Nm).

6. Engage the throttle position sensor and the idle air bypass valve.

7. Connect the negative battery cable.

### 4.6L Engine

#### ▶ See Figures 22 thru 29

1. Disconnect the negative battery cable.

2. Remove the air cleaner outlet tube from the throttle body.

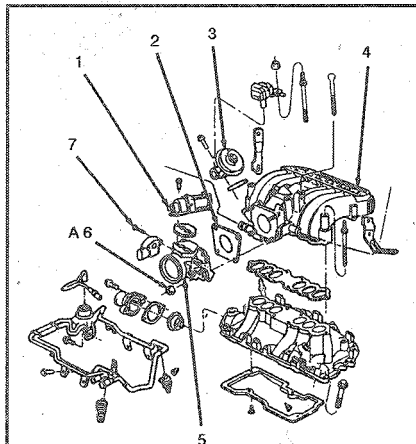

1. Idle air bypass valve
2. Gasket
3. EGR valve
4. Upper intake manifold
5. Throttle body
- 6A. Nut
7. Screw
- A. Tighten to 25 N.m (19 lb-ft)

86875A26

**Fig. 21 Throttle body and related components—3.8L engine**



91195P01

**Fig. 22 Detach the TP sensor connector**

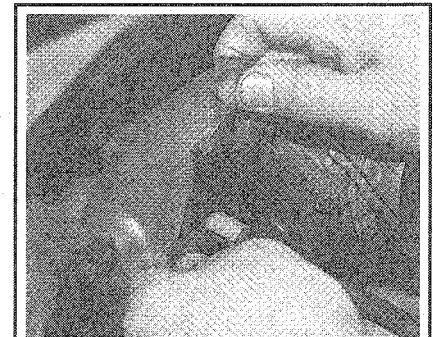

91195P02

**Fig. 23 Disconnect the accelerator cable from the throttle lever**

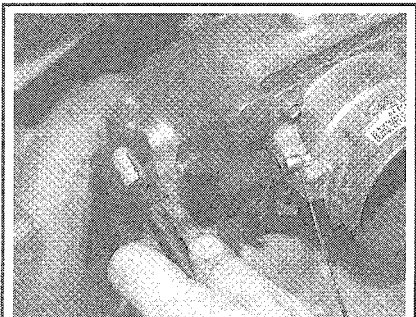

91195P03

**Fig. 24 If equipped with speed control, disconnect the speed control actuator from the throttle lever**



91195P04

**Fig. 25 Disconnect the accelerator return spring from the throttle body**

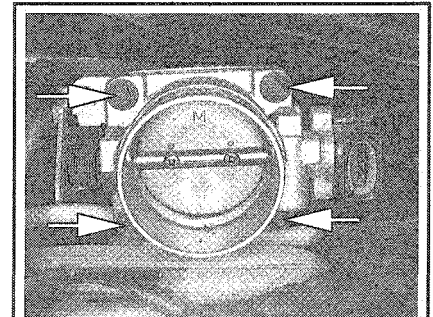

89605P14

**Fig. 26 Remove the four retaining bolts and . . .**

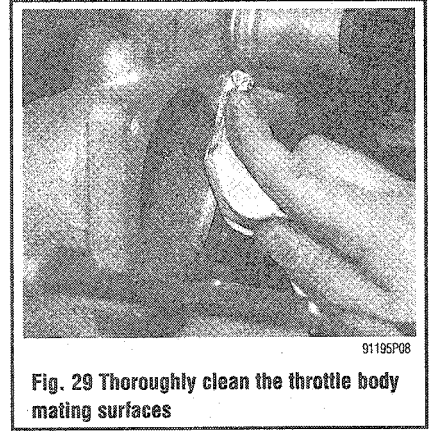
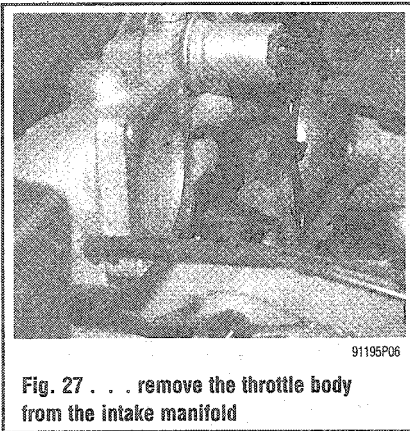

3. Disconnect the throttle position sensor and throttle linkage at the throttle lever.
4. Remove the 4 throttle body mounting bolts.
5. Carefully separate the throttle body from the intake manifold adapter.
6. Remove and discard the gasket between the throttle body adapter.
- To install:**
7. Clean all gasket mating surfaces, being careful not to damage them or allow material to drop into the manifold.
8. Install the throttle body, a new gasket and the 4 mounting bolts. Tighten the bolts to 6–8.5 ft. lbs. (8–11.5 Nm).
9. Connect the throttle position sensor and the throttle linkage.
10. Install the air cleaner outlet tube.
11. Connect the negative battery cable.

6. Carefully separate the throttle body from the EGR spacer and intake manifold.
7. Remove and discard the gasket between the throttle body and EGR spacer.
- To install:**
8. Clean all gasket mating surfaces, being careful not to damage them or allow material to drop into the manifold.
9. Install the throttle body with a new gasket on the 4 studs of the EGR spacer. Install the nuts and tighten to 12–18 ft. lbs. (16–24 Nm).
10. Connect the PCV vent closure hose.
11. Connect the throttle position sensor and idle air control valve connectors.
12. Install the air cleaner outlet tube.
13. Connect the negative battery cable.

**Fig. 29 Thoroughly clean the throttle body mating surfaces**

- g. Remove the 2 canister purge lines from the fittings on the throttle body, then remove the 6 upper intake manifold retaining bolts.
- h. Remove 2 retaining bolts on the front and rear edges of the upper intake manifold where the manifold support brackets are located.
- i. Remove the nut retaining the alternator bracket to the upper intake manifold and the 2 bolts retaining the alternator bracket to the water pump and alternator.
- j. Remove the upper intake manifold and throttle body as an assembly.
- k. Disconnect the fuel supply and return lines from the fuel rail assembly.
- l. Remove the fuel rail assembly retaining bolts, carefully disengage the fuel rail from the fuel injectors, and then remove the fuel rail.
5. Remove the injector retaining clips.
6. Remove the electrical connectors from the fuel injectors.
7. To remove the injector, pull it up while gently rocking it from side-to-side.
8. Inspect the injector O-rings, pintle protection cap (plastic hat) and washer for deterioration and replace, as required.

## Fuel Rail and Fuel Injector(s)

### REMOVAL & INSTALLATION

#### 5.0L Engine

##### See Figure 30

1. Disconnect the negative battery cable.
2. Remove the air cleaner outlet tube from the throttle body.
3. Detach the throttle position sensor and idle air control valve connectors.
4. Remove the PCV vent closure hose at the throttle body.
5. Remove the 4 throttle body mounting nuts.

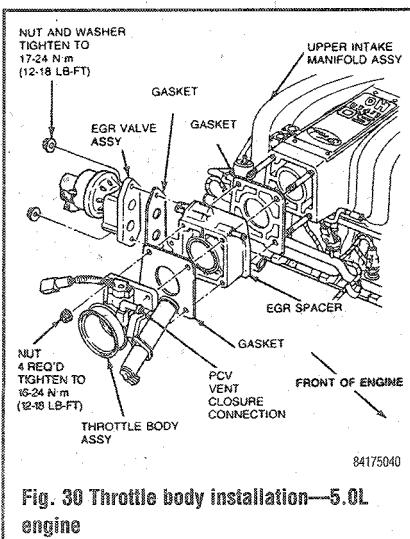

#### 3.8L Engine

##### See Figures 31

1. Disconnect the negative battery cable.
2. Remove the fuel cap at the tank to release the fuel tank pressure.
3. Properly relieve the pressure from the fuel system. For details, please refer to the procedure located earlier in this section.
4. Remove the upper intake manifold and the fuel supply manifold as follows:
  - a. Disengage the electrical connectors at the air bypass valve, TP sensor, and EGR position sensor.
  - b. Disconnect the throttle linkage at the throttle ball and the transmission linkage from the throttle body. Remove the 2 bolts securing the bracket to the intake manifold and position the bracket with the cables aside.
  - c. Disconnect the upper intake manifold vacuum fitting connections by disconnecting all vacuum lines to the vacuum tree, EGR valve and pressure regulator.
  - d. Disconnect the PCV hose and remove the nut retaining the EGR transducer to the upper intake manifold.
  - e. Loosen the EGR tube at the exhaust manifold, then disconnect at the EGR valve.
  - f. Remove 2 bolts retaining the EGR valve to the upper intake manifold, then remove the EGR valve and EGR transducer as an assembly.

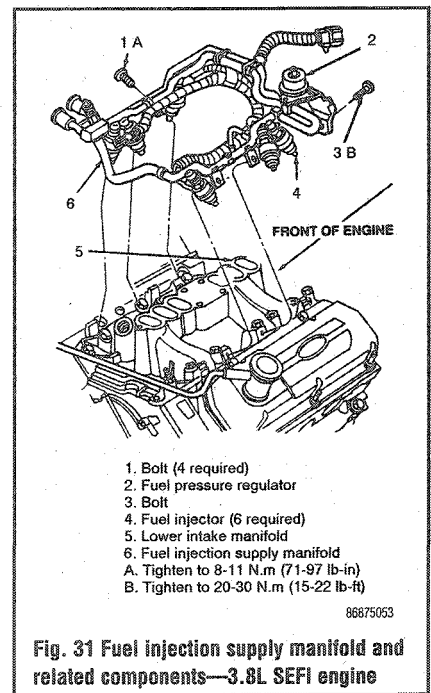

**Fig. 31 Fuel injection supply manifold and related components—3.8L SEFI engine**

# 5-8 FUEL SYSTEM

## To install:

- Lubricate new engine O-rings with engine oil and install 2 on each injector.
- Install the injectors, using a light, twisting, pushing motion to install them.
- Reconnect the injector retaining clips.
- Install the fuel rail assembly.
- Install the electrical harness connectors to the injectors.
- Install the upper intake manifold by reversing the removal procedure.
- Install the fuel cap at the tank.
- Connect the negative battery cable.
- Turn the ignition switch from ON to OFF position several times without starting the engine to check for fuel leaks.

## 4.6L Engine

### See Figures 32 thru 37

- Disconnect the negative battery cable.
- Remove the fuel tank cap and relieve the fuel system pressure, as explained in this Section.
- Disconnect the vacuum line at the pressure regulator.
- Disconnect the fuel lines from the fuel rail.
- Detach the electrical connectors from the injectors.
- Remove the fuel rail assembly retaining bolts.
- Carefully disengage the fuel rail from the fuel injectors and remove the fuel rail.

It may be easier to remove the injectors with the fuel rail as an assembly.

8. Grasping the injector body, pull while gently rocking the injector from side-to-side to remove the injector from the fuel rail or intake manifold.

9. Inspect the pintle protection cap and washer for signs of deterioration. Replace the complete injector, as required. If the cap is missing, look for it in the intake manifold.

The pintle protection cap is not available as a separate part.

## To install:

10. Lubricate new O-rings with light grade oil and install 2 on each injector.

Never use silicone grease as it will clog the injectors.

- Install the injectors using a light, twisting, pushing motion.
- Install the fuel rail, pushing it down to ensure all injector O-rings are fully seated in the fuel rail cups and intake manifold.
- Install the retaining bolts while holding the fuel rail down and tighten to 71–106 inch lbs. (8–12 Nm).
- Connect the fuel lines to the fuel rail and the vacuum line to the pressure regulator.
- With the injector wiring disconnected, connect the negative battery cable and turn the ignition switch to the **RUN** position to allow the fuel pump to pressurize the system.
- Check for fuel leaks.
- Disconnect the negative battery cable.
- Connect the electrical connectors to the fuel injectors.

19. Connect the negative battery cable and start the engine. Let it idle for 2 minutes.

20. Turn the engine **OFF** and check for leaks.

## 5.0L Engine

### See Figure 38

- Disconnect the negative battery cable.
- Remove the fuel tank cap and relieve the fuel system pressure, as explained in this Section.
- Partially drain the cooling system into a suitable container.

## CAUTION

When draining the coolant, keep in mind that cats and dogs are attracted by the ethylene glycol antifreeze, and are quite likely to drink any that is left in an uncovered container or in puddles on the ground. This will prove fatal in sufficient quantity. Always drain the coolant into a sealable container. Coolant should be reused unless it is contaminated or several years old.

- Label and detach the electrical connectors at the idle air control valve, throttle position sensor and EGR sensor.
- Disconnect the throttle linkage at the throttle ball and transmission linkage from the throttle body. Remove the 2 bolts securing the bracket to the intake manifold and position the bracket with the cables aside.
- Label and disconnect the upper intake manifold vacuum fitting connections by disconnecting

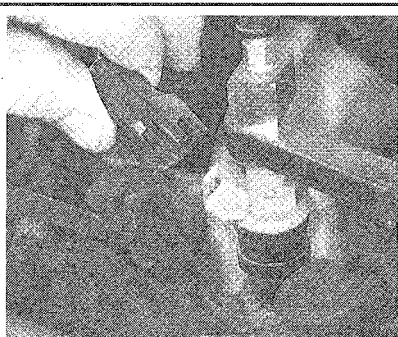

89605P04

Fig. 32 Detach the electrical connectors from the injectors

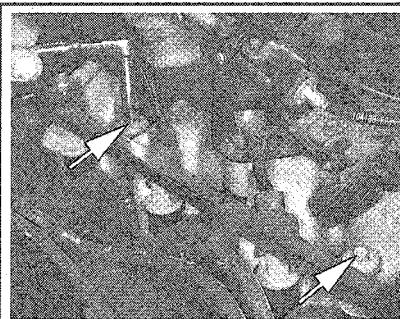

89605P05

Fig. 33 Remove the fuel rail assembly retaining bolts. There are two on each side of the engine



89605P06

Fig. 34 Lift the rail from the intake manifold and . . .

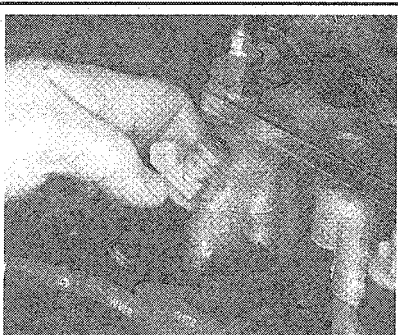

89605P07

Fig. 35 . . . remove the injectors by gently pulling them out of the rail

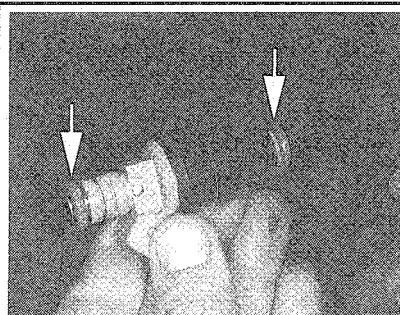

89605P09

Fig. 36 Replace the injector O-rings before installing the injectors back into the engine

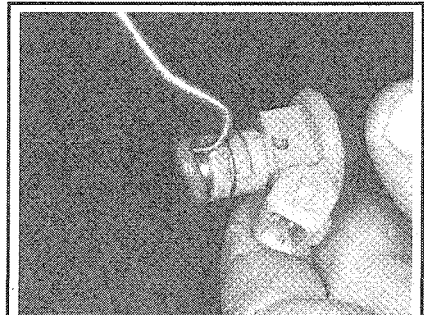

89605P08

Fig. 37 Remove the O-rings from the injectors using a small pick or other suitable tool



all vacuum lines to the vacuum tree, EGR valve, fuel pressure regulator and evaporative canister.

7. Disconnect the PCV hose from the fitting on the rear of the upper manifold and disconnect the PCV vent closure tube at the throttle body.

8. Remove the 2 EGR coolant lines from the fittings on the EGR spacer.

9. Remove the 6 upper intake manifold retaining bolts.

10. Remove the upper intake and throttle body as an assembly from the lower intake manifold.

11. Disconnect the fuel lines from the fuel rail.

12. Remove the 4 fuel rail assembly retaining bolts.

13. Detach the electrical connectors from the injectors.

14. Carefully disengage the fuel rail from the fuel injectors.

➔ **It may be easier to remove the injectors with the fuel rail as an assembly.**

15. Grasping the injector body, pull up while gently rocking the injector from side-to-side to remove the injector from the fuel rail or intake manifold.

16. Inspect the pintle protection cap and washer for signs of deterioration. Replace the complete injector, as required. If the cap is missing, look for it in the intake manifold.

➔ **The pintle protection cap is not available as a separate part.**

### To install:

17. Lubricate new O-rings with light grade oil and install 2 on each injector.

➔ **Never use silicone grease as it will clog the injectors.**

18. Install the injectors using a light, twisting, pushing motion.

19. Install the fuel rail, pushing it down to ensure all the injector O-rings are fully seated in the fuel rail cups and intake manifold.

20. Install the retaining bolts while holding the fuel rail down and tighten to 71–106 inch lbs. (8–12 Nm).

21. Connect the fuel lines to the fuel rail.

22. With the injector wiring disconnected, connect the negative battery cable and turn the ignition switch to the **RUN** position to allow the fuel pump to pressurize the system.

23. Check for fuel leaks.

24. Disconnect the negative battery cable.

25. Connect the electrical connectors to the injectors.

26. Install the upper intake manifold and throttle body assembly by reversing the removal procedure. Use a new gasket and tighten the retaining bolts to 12–18 ft. lbs. (16–24 Nm).

27. Refill the cooling system and connect the negative battery cable.

28. Start the engine and let it idle for 2 minutes. Turn the engine **OFF** and check for leaks.

from the injectors while the engine is running. This is accomplished using a mechanic's stethoscope, or a long screwdriver. Place the end of the stethoscope or the screwdriver (tip end, not handle) onto the body of the injector. Place the ear pieces of the stethoscope in your ears, or if using a screwdriver, place your ear on top of the handle. An audible clicking noise should be heard; this is the solenoid operating. If the injector makes this noise, the injector driver circuit and computer are operating as designed. Continue testing all the injectors this way.

### CAUTION

**Be extremely careful while working on an operating engine, make sure you have no dangling jewelry, loose clothing, power tool cords or other items that might get caught in a moving part of the engine.**

### All Injectors Clicking

If all the injectors are clicking, but you have determined that the fuel system is the cause of your driveability problem, continue diagnostics. Make sure that you have checked fuel pump pressure as outlined earlier in this section. An easy way to determine a weak or unproductive cylinder is a cylinder drop test. This is accomplished by removing one spark plug wire at a time, and seeing which cylinder causes the least difference in the idle. The one that causes the least change is the weak cylinder.

If the injectors were all clicking and the ignition system is functioning properly, remove the injector of the suspect cylinder and bench test it. This is accomplished by checking for a spray pattern from the injector itself. Install a fuel supply line to the injector (or rail if the injector is left attached to the rail) and momentarily apply 12 volts DC and a ground to the injector itself; a visible fuel spray should appear. If no spray is achieved, replace the injector and check the running condition of the engine.

### One or More Injectors Are Not Clicking

♦ See Figures 39, 40, 41 and 42

If one or more injectors are found to be not operating, testing the injector driver circuit and computer can be accomplished using a "noid" light. First, with the engine not running and the ignition key in the **OFF** position, remove the connector from

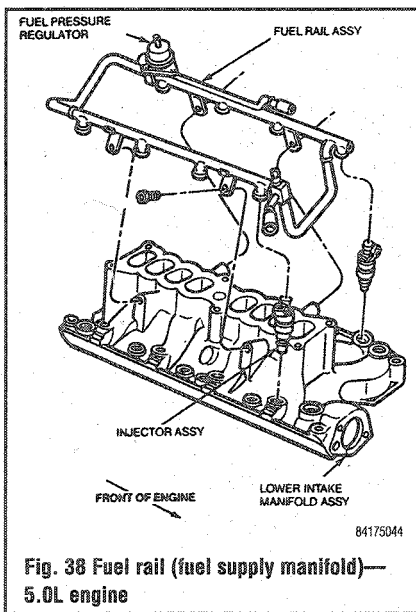

**Fig. 38 Fuel rail (fuel supply manifold)—5.0L engine**

### TESTING

The easiest way to test the operation of the fuel injectors is to listen for a clicking sound coming

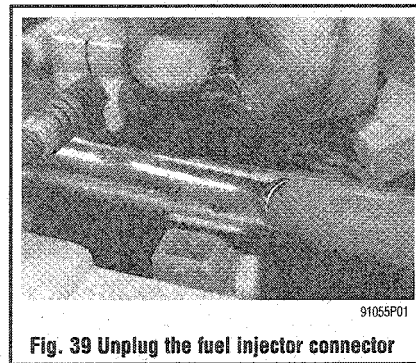

**Fig. 39 Unplug the fuel injector connector**

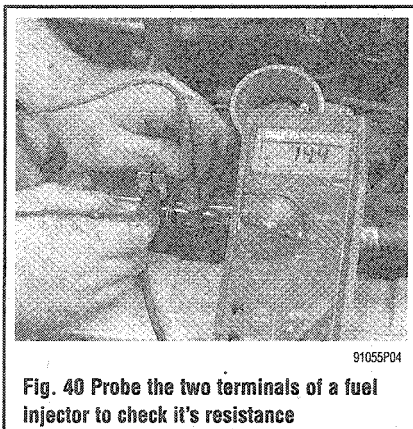

**Fig. 40 Probe the two terminals of a fuel injector to check its resistance**

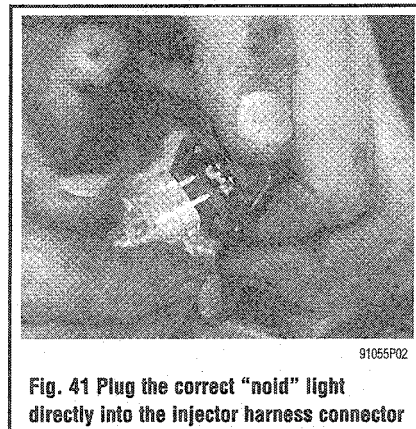

**Fig. 41 Plug the correct "noid" light directly into the injector harness connector**

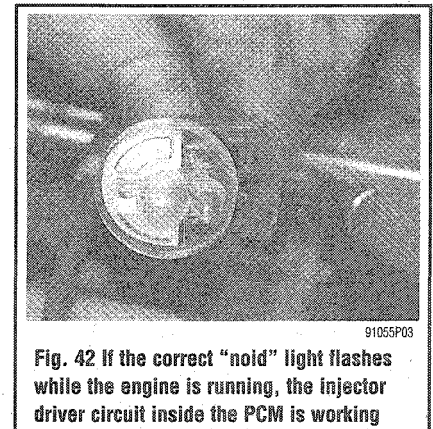

**Fig. 42 If the correct "noid" light flashes while the engine is running, the injector driver circuit inside the PCM is working**

the injector you plan to test, then plug the "noid" light tool into the injector connector. Start the engine and the "noid" light should flash, signaling that the injector driver circuit is working. If the "noid" light flashes, but the injector does not click when plugged in, test the injector's resistance. resistance should be between 11–18 ohms.

If the "noid" light does not flash, the injector driver circuit is faulty. Disconnect the negative battery cable. Unplug the "noid" light from the injector connector and also unplug the PCM. Check the harness between the appropriate pins on the harness side of the PCM connector and the injector connector. Resistance should be less than 5.0 ohms; if not, repair the circuit. If resistance is within specifications, the injector driver inside the PCM is faulty and replacement of the PCM will be necessary.

## Fuel Pressure Regulator

### REMOVAL & INSTALLATION

▶ See Figures 43, 44, 45 and 46

1. Disconnect the negative battery cable.
2. Remove the fuel tank cap and relieve the fuel system pressure, as explained in this section.
3. Disconnect the vacuum line at the pressure regulator.
4. Remove and discard the 3 Allen head screws retaining the regulator housing.
5. Remove the pressure regulator, gasket and O-ring.
6. If scraping is necessary to remove old gasket material, be careful not to damage the

pressure regulator or fuel supply manifold gasket surfaces.

#### To install:

7. Lubricate a new fuel pressure regulator O-ring with clean engine oil.
- ▶ **Never use silicone grease as it will clog the injectors.**
8. Make sure the pressure regulator and fuel supply manifold gasket mating surfaces are clean.
9. Install the new O-ring and new gasket on the pressure regulator.
10. Install the fuel pressure regulator on the fuel supply manifold. Install new Allen screws and tighten to 27–40 inch lbs. (3–4.5 Nm).
11. Connect the vacuum line to the pressure regulator.

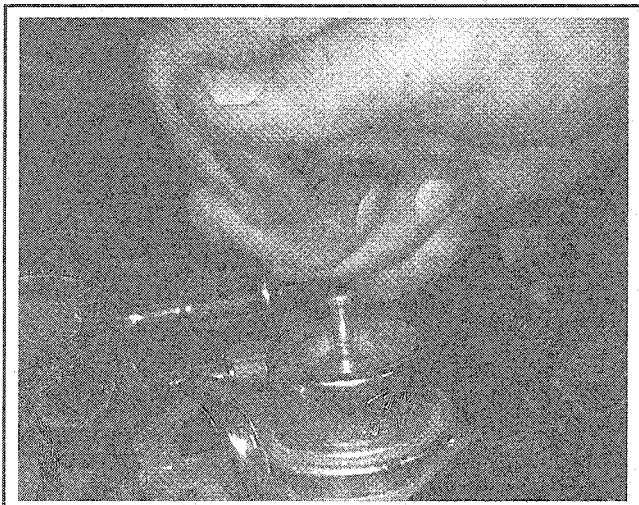

89605P10

Fig. 43 Remove the vacuum hose from the pressure regulator



89605P12

Fig. 45 . . . lift the regulator off of the rail



89605P11

Fig. 44 Remove the pressure regulator retaining screws and . . .

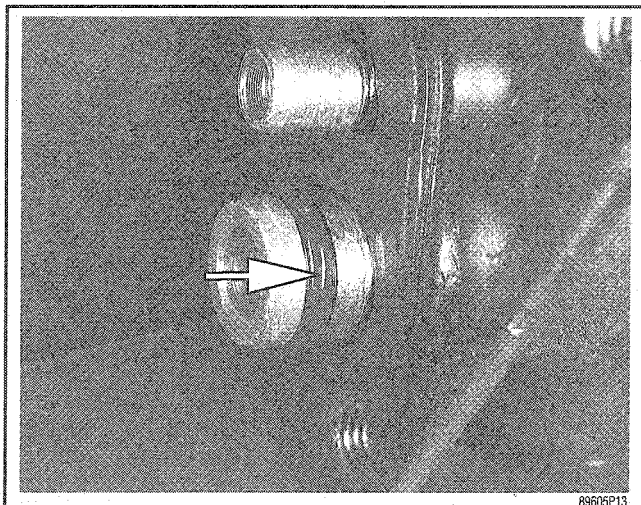

89605P13

Fig. 46 Replace the O-ring on the bottom of the fuel pressure regulator

12. Connect the negative battery cable and turn the ignition switch to the **RUN** position to allow the fuel pump to pressurize the system.
13. Check for fuel leaks.
14. Start the engine and let it idle for 2 minutes. Turn the engine **OFF** and check for leaks.

## Pressure Relief Valve

### REMOVAL & INSTALLATION

▶ See Figure 47

1. Disconnect the negative battery cable.
2. Properly relieve the fuel system pressure.
3. Remove the air cleaner outlet tube(s).



89605P03

**Fig. 47** The fuel pressure relief valve is located on the fuel rail, under the protective cap

4. Remove any necessary components to access the pressure relief valve.
5. Remove the cap from the pressure relief valve.
6. Remove the pressure relief valve from the fuel rail using the proper size socket and drive tool.

#### To install:

7. The installation is the reverse of the removal.

## FUEL TANK

### Tank Assembly

#### REMOVAL & INSTALLATION

1. Disable the air suspension, if equipped.
2. Disconnect the negative battery cable and relieve the fuel system pressure.
3. Siphon or pump as much fuel as possible out through the fuel filler pipe.

▶ **Fuel injected vehicles have reservoirs inside the fuel tank to maintain fuel near the fuel pickup during cornering and under low fuel operating conditions. These reservoirs could block siphon tubes or hoses from reaching the bottom of the fuel tank. Repeated attempts using different hose orientations can overcome this obstacle.**

4. Raise and safely support the vehicle.
5. If equipped with a metal retainer that fastens the filler pipe to the fuel tank, remove the screw attaching the retainer to the fuel tank flange.
6. Detach the fuel lines and the electrical connector to the fuel tank sending unit. On some vehicles, these are inaccessible on top of the tank. In these cases they must be disconnected with the tank partially removed.
7. Place a safety support under the fuel tank and remove the bolts or nuts from the fuel tank straps. Allow the straps to swing out of the way.
8. Partially remove the tank and detach the fuel lines and electrical connector from the sending unit, if not detached previously.
9. Remove the tank from the vehicle.

#### To install:

10. Raise the fuel tank into position in the vehicle. Connect the fuel lines and sending unit electrical connector if it is necessary to connect them before the tank is in the final installed position.
11. Lubricate the fuel filler pipe with water base tire mounting lubricant and install the tank onto the filler pipe, then bring the tank into final position. Be careful not to deform the tank.
12. Bring the fuel tank straps around the tank and start the retaining nut or bolt. Align the tank with the straps. If equipped, make sure the fuel tank shields are installed with the straps and are positioned correctly on the tank.

13. Check the hoses and wiring mounted on the tank top to make sure they are correctly routed and will not be pinched between the tank and body.

14. Tighten the fuel tank strap retaining nuts or bolts to 20–30 ft. lbs. (28–40 Nm).

15. If not already connected, connect the fuel hoses and lines which were detached. Make sure the fuel supply, fuel return, if present, and vapor vent connections are made correctly. If not already connected, connect the sending unit electrical connector.

16. Lower the vehicle.
17. Replace the fuel that was drained from the tank.
18. Check all connections for leaks.

## Electric Fuel Pump

### REMOVAL & INSTALLATION

▶ See Figures 48, 49 and 50

#### \*\* CAUTION

**Fuel injection systems remain under pressure, even after the engine has been turned OFF. The fuel system pressure must be relieved before disconnecting any fuel lines. Failure to do so may result in fire and/or personal injury.**



89605P02

**Fig. 48** The fuel pump is located in the fuel tank. On some models it can be viewed from the side as shown here

1. If equipped with air suspension, the air suspension switch, located on a side panel of the trunk compartment, must be turned to the **OFF** position before raising the vehicle.

2. Disconnect the negative battery cable.
3. Relieve fuel system pressure using the recommended procedure.

4. Raise and safely support the vehicle.

5. Remove the fuel tank from the vehicle and place on a suitable work bench.

6. Remove any dirt that has accumulated around the fuel pump retaining flange so it will not enter the tank during pump removal and installation.

7. On 1988–94 models, turn the fuel pump locking ring counterclockwise and remove the locking ring.

8. On 1995–00 models, remove the retaining bolts around the perimeter of the fuel pump module.

9. Remove the fuel pump/sending unit assembly. Remove and discard the seal ring.

#### To install:

10. Clean the fuel pump mounting flange, fuel tank mounting surface and seal ring groove.

11. Apply a light coating of grease on a new seal ring to hold it in place during assembly and install it in the seal ring groove.

12. Install the fuel pump/sending unit assembly carefully to ensure the filter is not damaged. Make sure the locating keys are in the keyways and the seal ring remains in the groove.

13. Hold the pump assembly in place and install the locking ring finger-tight. Make sure all the locking tabs are under the tank lock ring tabs.

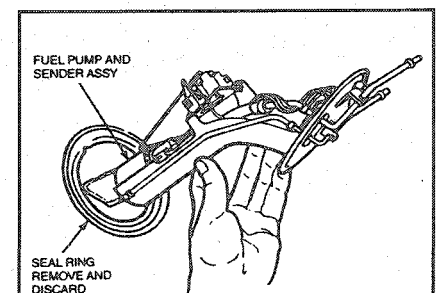

84175037

**Fig. 49** Electric fuel pump removal

## 5-12 FUEL SYSTEM

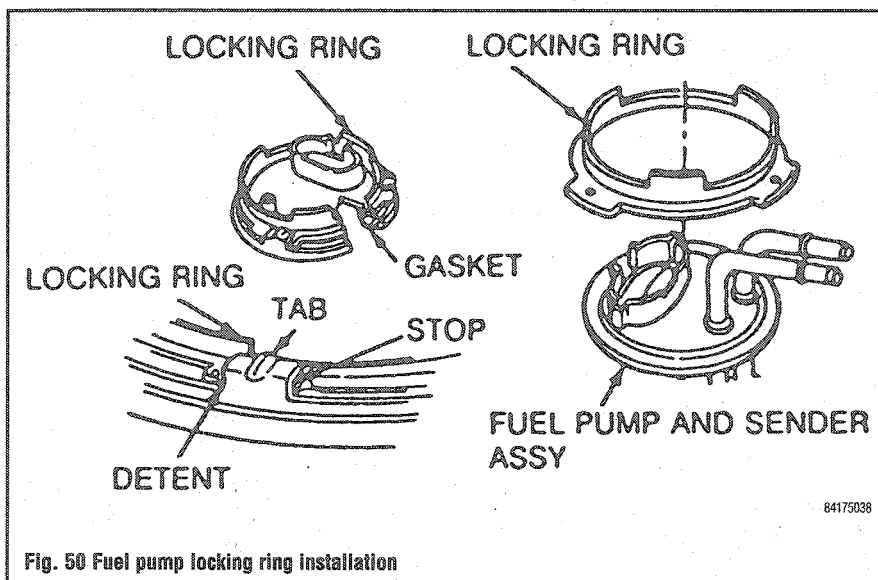

Fig. 50 Fuel pump locking ring installation

14. Rotate the locking ring clockwise until the ring is against the stops.
15. Install the fuel tank into the vehicle.
16. Lower the vehicle.
17. If equipped with air suspension, turn the air suspension switch to the **ON** position.
18. Add a minimum of 10 gallons of fuel to the tank and check for leaks.
19. Reconnect the negative battery cable.
20. Turn the ignition switch to the **RUN** position several times to pressurize the fuel system. Check for fuel leaks and correct as necessary.
21. Start the engine and check for leaks.
22. Road test the vehicle and check for proper operation.