

TUNE-UP PROCEDURES

Introduction

In order to extract the full measure of performance and economy from your engine, it is essential that it be properly tuned at regular intervals. A regular tune-up will keep your car's engine running smoothly and will prevent the annoying breakdowns and poor performance associated with an untuned engine.

A complete tune-up should be performed at least every 12,000 miles (19,200 km) or 12 months, whichever comes first. The interval should be halved if the vehicle is operated under severe conditions such as trailer towing, prolonged idling, start-and-stop driving, or if a driveability problem such as hard starting or poor running is noticed. It is assumed that the routine maintenance described in **Section 1** has been kept up, as this will have a decided effect on the results of a tune-up.

If the specifications on the underhood tune-up sticker (located in the engine compartment of your car) disagree with the tune-up specifications chart in this section, the figures on the sticker must be used. The sticker often reflects changes made during the production run or revised information that applies to the particular systems in that vehicle.

Spark Plugs

A typical spark plug consists of a metal shell surrounding a ceramic insulator. A metal electrode extends downward through the center of the insulator and protrudes a small distance. Located at the end of the plug and attached to the side of the outer metal shell is the side electrode. The side electrode bends in at a 90° angle so that its tip is even with, and parallel to, the tip of the center electrode. The distance between these two electrodes (measured in thousandths of an inch) is called the spark plug gap. The spark plug in no way produces a spark, but merely provides a gap across which the current can arc. The coil produces anywhere from 20,000-40,000 volts which travels to the distributor, where it is transmitted through the spark plug wires to the spark plugs. The current passes along the center electrode, and, in doing so, ignites the air/fuel mixture in the combustion chamber.





A variety of tools and gauges are needed for spark plug service

Spark plugs ignite the air and fuel mixture in the cylinder as the piston reaches the top of the compression stroke. The controlled explosion that results forces the piston down, turning the crankshaft and the rest of the drive train.

The average life of a spark plug is dependent on a number of factors; the mechanical condition of the engine, the type of fuel, driving conditions and driving style.

Ford recommends that spark plugs be changed every 30,000 miles (48,000 km). Under severe driving conditions, those intervals should be halved. Severe driving conditions are:

- **Extended periods of idling or low speed operation, such as off-road or door-to-door delivery.**
- **Driving short distances (less than 10 miles/16 km) when the average temperature is below 10°F (12°C) for 60 days or more.**
- **Excessive dust or blowing dirt conditions.**

When you remove the spark plugs, check their condition. They are a good indicator of the condition of the engine. It is a good idea to remove the spark plugs at regular intervals, such as every 6,000 or so miles (9,600 km), just so you can keep an eye on the mechanical state of the engine.

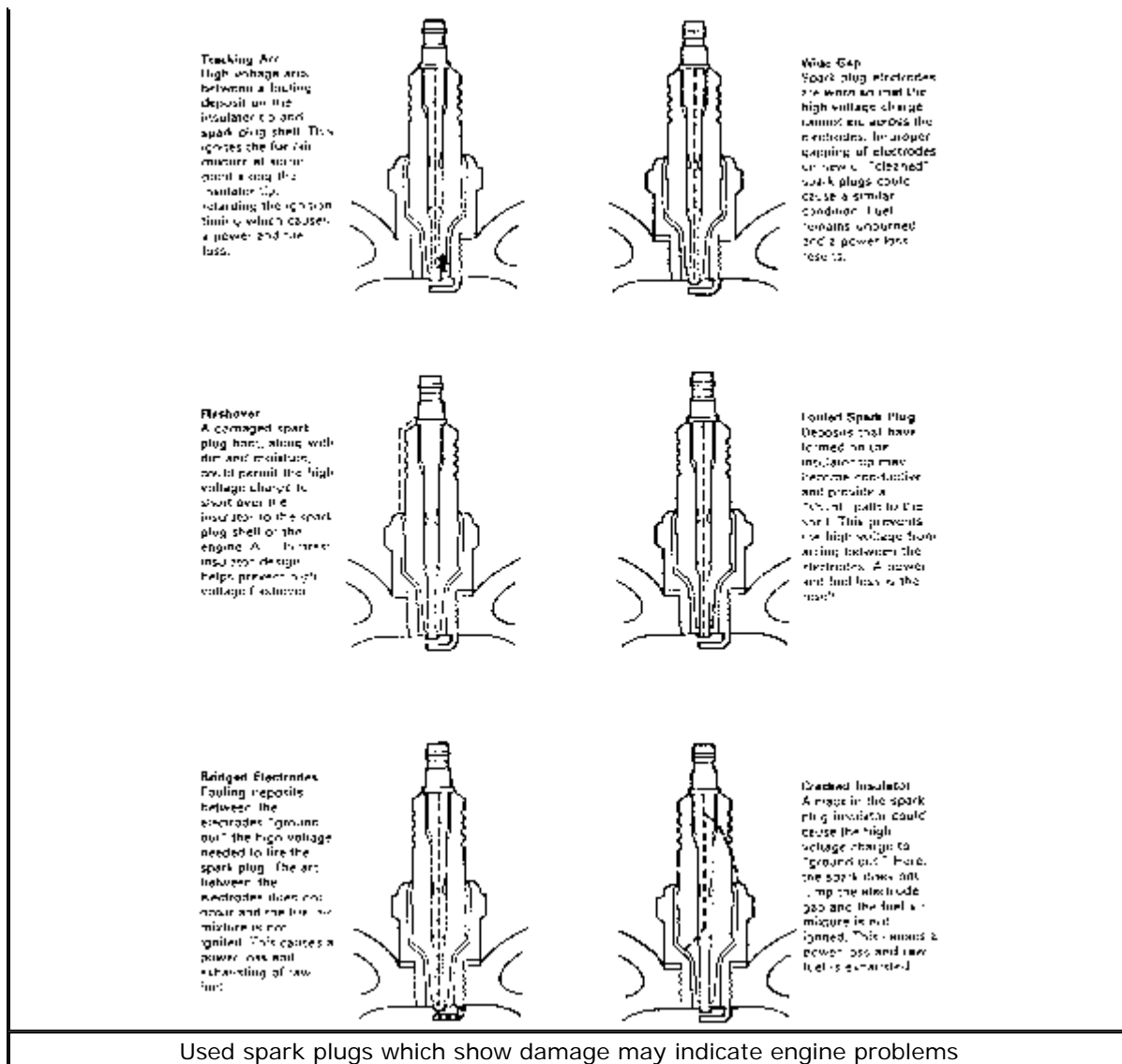

[Click to enlarge](#)

A small deposit of light tan or gray material on a spark plug that has been used for any period of time is considered normal. Any other color, or abnormal amounts of deposit, indicate that there is something amiss in the engine.

The gap between the center electrode and the side or ground electrode can be expected to increase not more than 0.001 in. (0.025mm) every 1,000 miles (1,600 km) under normal conditions. When, and if, a plug fouls and begins to misfire, you will have to investigate, correct the cause of the fouling and either clean or replace the plug.

There are several reasons why a spark plug will foul and you can learn which reason is at fault by just looking at the plug. A few of the most common reasons for plug fouling and a description of fouled plug appearance are shown in the corresponding chart.

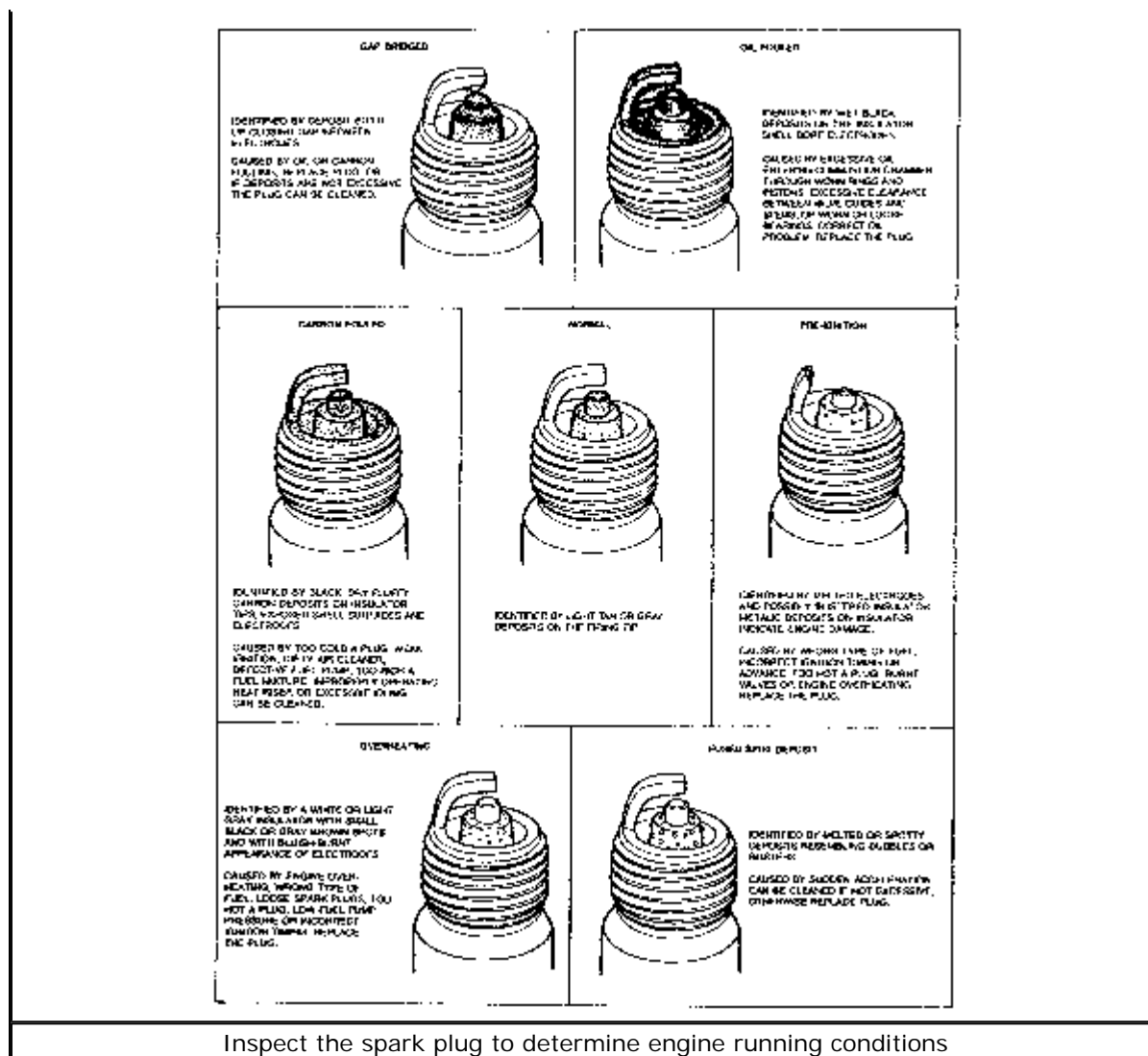

[Click to enlarge](#)

SPARK PLUG HEAT RANGE

Spark plug heat range is the ability of the plug to dissipate heat. The longer the insulator (or the farther it extends into the engine), the hotter the plug will operate; the shorter the insulator, the cooler it will operate. A plug that absorbs little heat and remains too cool will quickly accumulate deposits of oil and carbon since it is not hot enough to burn them off. This leads to plug fouling and consequently to misfiring. A plug that absorbs too much heat will have no deposits, but, due to the excessive heat, the electrodes will burn away quickly and in some instances, preignition may result. Preignition takes place when plug tips get so hot that they glow sufficiently to ignite the fuel/air mixture before the actual spark occurs. This early ignition will usually cause a pinging during low speeds and heavy loads.

The general rule of thumb for choosing the correct heat range when selecting a spark plug is: if most of your driving is long distance, high speed travel, use a cooler plug; if most of your driving is stop and go, use a hotter plug. Original equipment plugs are compromise plugs, but most people never have occasion to change their plugs from the factory recommended heat range.

REPLACING SPARK PLUGS

A set of spark plugs usually requires replacement every 30,000 miles (48,000 km), depending on your style of driving. In normal operation, plug gap increases about 0.001 in. (0.025mm) for every 1,000-2,500 miles (1,600-4,000 km). As the gap increases, the plug's voltage requirement also increases. It requires greater voltage to jump the wider gap and about two-to-three times as much voltage to fire a plug at higher speeds than at idle.

The spark plugs used in your car require a deep spark plug socket for removal and installation. A specially designed pair of wire removal pliers, Spark Plug Wire Remover T74P-6666-A or equivalent, is also a good tool to have for vehicles other than the 3.0L/3.2L SHO. The special pliers have cupped jaws that grip the plug wire boot and make the job of twisting and pulling the wire from the plug easier.

REMOVAL & INSTALLATION

When you are removing spark plugs, you should work on one at a time. Avoid removing the plug wires all at once because, unless you number them, they may get mixed up; if you must (or prefer to) do so, take a minute before removing the wires to number them with tape. The time you spend doing this will pay off later when it comes time to reconnect the wires to the plugs.

The original spark plug wires are marked for cylinder location. If replacement wires have been installed, be sure to tag them for proper location. It is a good idea to remove the wires one at a time, service the spark plug, reinstall the wire and move onto the next cylinder.

For easy access when servicing the spark plugs, remove the air cleaner assembly and air intake tube.

1. **Disconnect the negative battery cable.**
2. **Twist the spark plug boot and gently pull it from the spark plug. For all vehicles except the 3.0L and the 3.2L SHO, using the special plug wire pliers will aid in ease of removal and prevent damage to the wire and inside connector.**

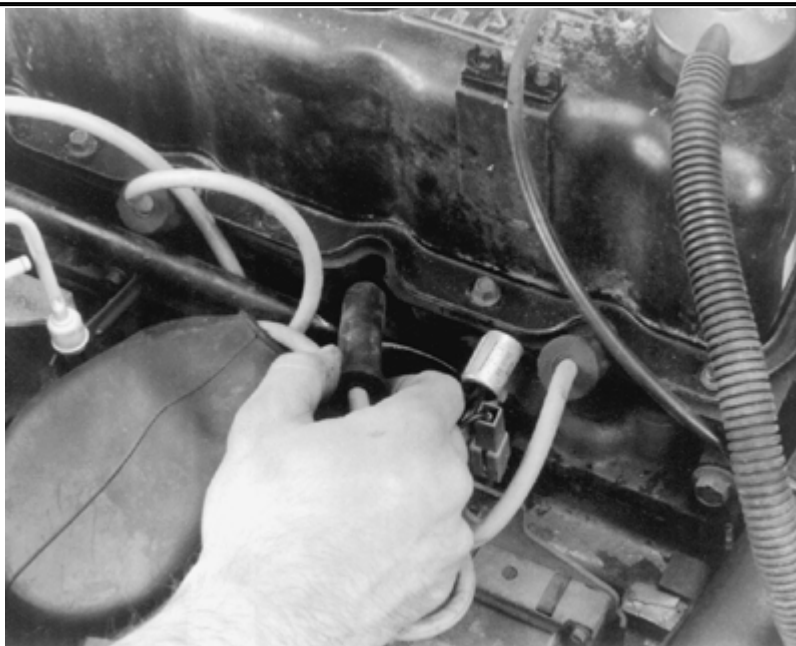

Gently twist and pull the boot to remove the spark plug wire; NEVER pull on the wire itself

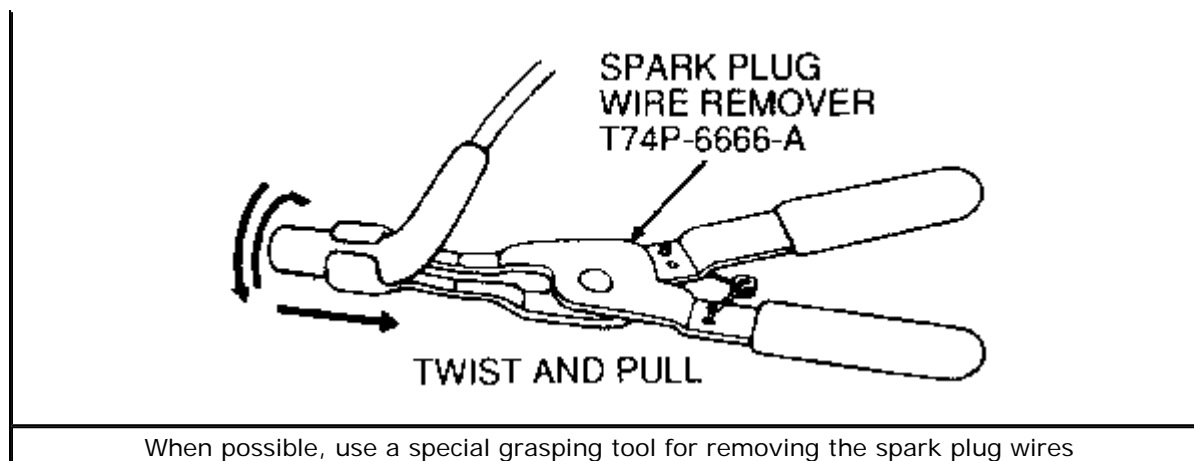

WARNING

NEVER pull on the wire itself, as damage to the inside conductor could occur! If available, use Spark Plug Remover Tool Y74P-6666-A or equivalent to prevent the wire separating from its connector inside the boot.

3. The plug wire boot has a cover which shields the plug cavity (in the cylinder head) against dirt. After removing the wire, blow out the cavity with compressed air or clean it out with a small brush, so no foreign material enters the cylinder when the spark plug is removed.
4. Remove the spark plug with a plug socket. Turn the socket counterclockwise to remove the plug. Be sure to hold the socket straight on the plug to avoid breaking the insulator. A deep socket designed for spark plugs has a rubber cushion built-in to help prevent plug breakage.

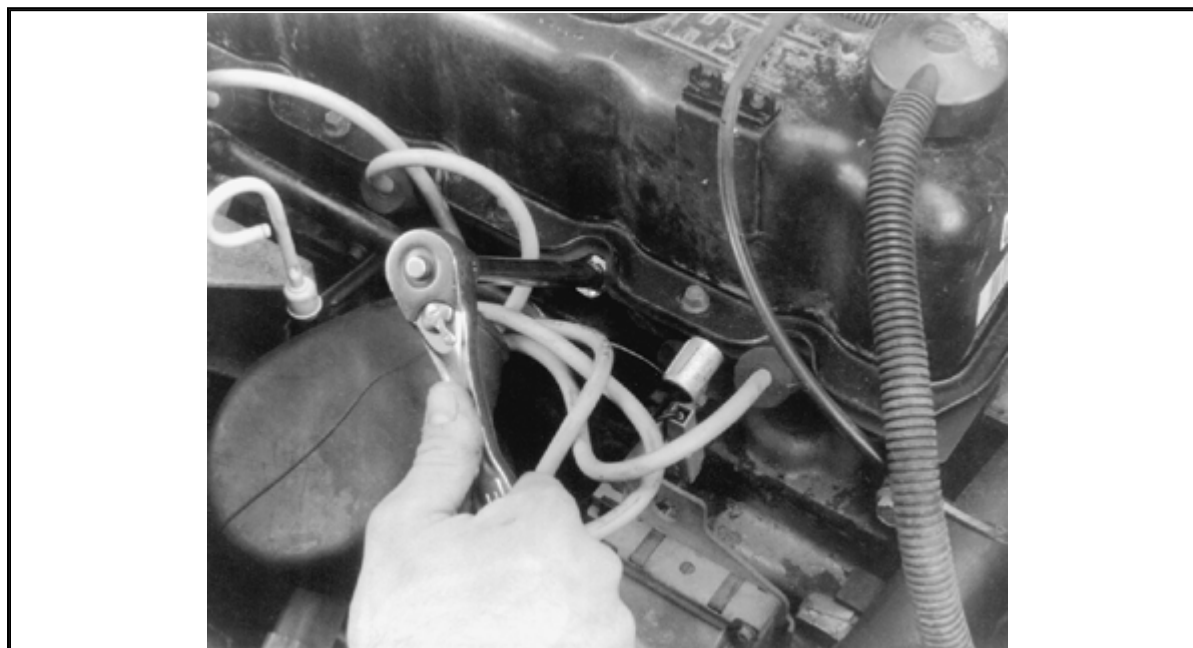

It will be easier to remove the spark plug using a socket with an extension

5. Once the plug is out, compare it with the spark plug illustrations to determine the engine condition. This is crucial since spark plug readings are vital signs of engine condition and pending problems.



Inspect the plug for signs of fouling or deposits

To install:

- 6. If the old plugs are to be reused, clean and regap them. If new spark plugs are to be installed, always check the gap. Use a round wire feeler gauge to check plug gap. The correct size gauge should pass through the electrode gap with a slight drag. If you're in doubt, try the next smaller and larger sizes. The smaller gauge should go through easily and the larger should not go through at all. If adjustment is necessary, use the bending tool on the end of the gauge. When adjusting the gap, always bend the side electrode. The center electrode is non-adjustable.**

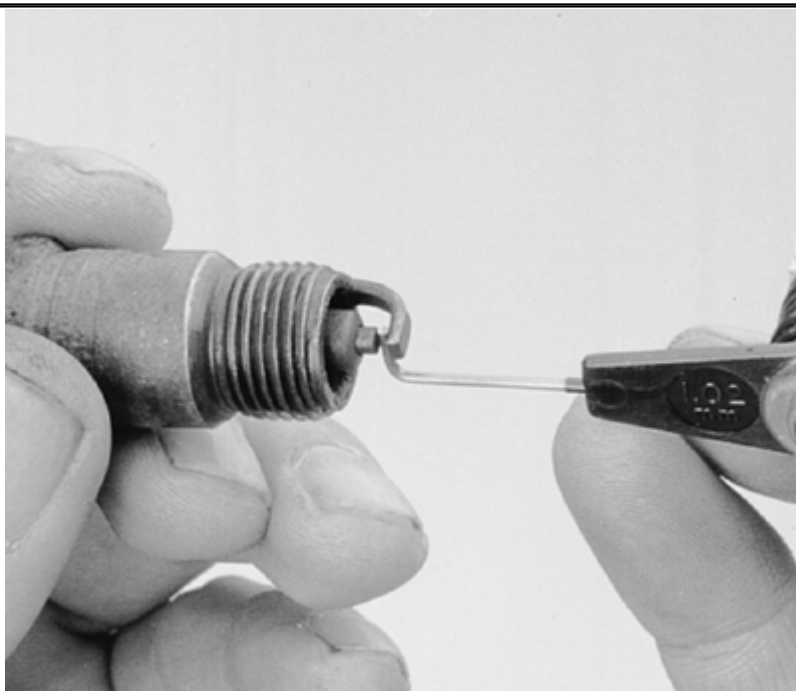

Always use a wire gauge to check the electrode gap on used plugs

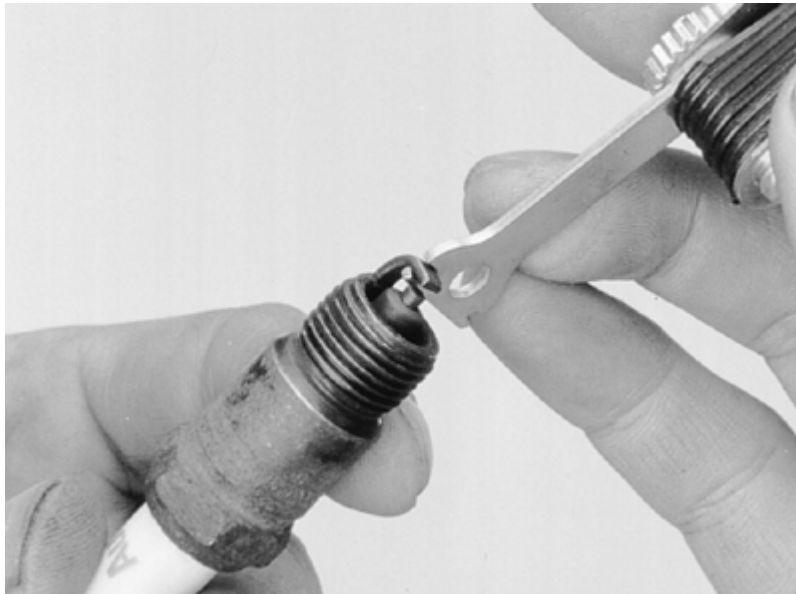

Adjust the gap by bending the side electrode very slightly towards or away from the center electrode

7. **Squirt a drop of penetrating oil on the threads of the spark plug and install it. Don't oil the threads heavily. Turn the plug in clockwise by hand until it is snug.**

CAUTION

Do NOT use the spark plug socket to thread the plugs. Always thread the plug by hand to prevent the possibility of cross-threading and damaging the cylinderhead.

8. **After the the plug is finger-tight, torque it to 17-22 ft. lbs. (23-30 Nm). DO NOT OVERTIGHTEN!**
9. **Thinly coat the inside of the boot and terminal with silicone dielectric compound (Motorcraft D7AZ-19A331-A or equivalent).**
10. **Install the plug wire boot firmly over the spark plug. Push the boot until it clicks into place. The click may be felt or heard, then gently pull back on the boot to assure proper contact.**
11. **Connect the negative battery cable.**

Spark Plug Wires

CHECKING AND REPLACING SPARK PLUG WIRES

Your car is equipped with an electronic ignition system which utilizes 8mm wires to conduct the hotter spark produced. The boots on these wires are designed to cover the spark plug cavities on the cylinder head.

Inspect the wires without removing them from the spark plugs, distributor cap or coil. Look for visible damage such as cuts, pinches, cracks or torn boots. Replace any wires that show damage. If the boot is damaged, it may be replaced by itself. It is not necessary to replace the complete wire just for the boot.

To remove the wire, grasp and twist the boot back and forth while pulling away from the spark plug. Use the specialized pliers mentioned earlier in this section, if

available. For 3.0L and 3.2L SHO vehicles, in order to remove the wires from the ignition coil, squeeze the locking tabs of the ignition wire retainer and use a gentle twisting/pulling motion.

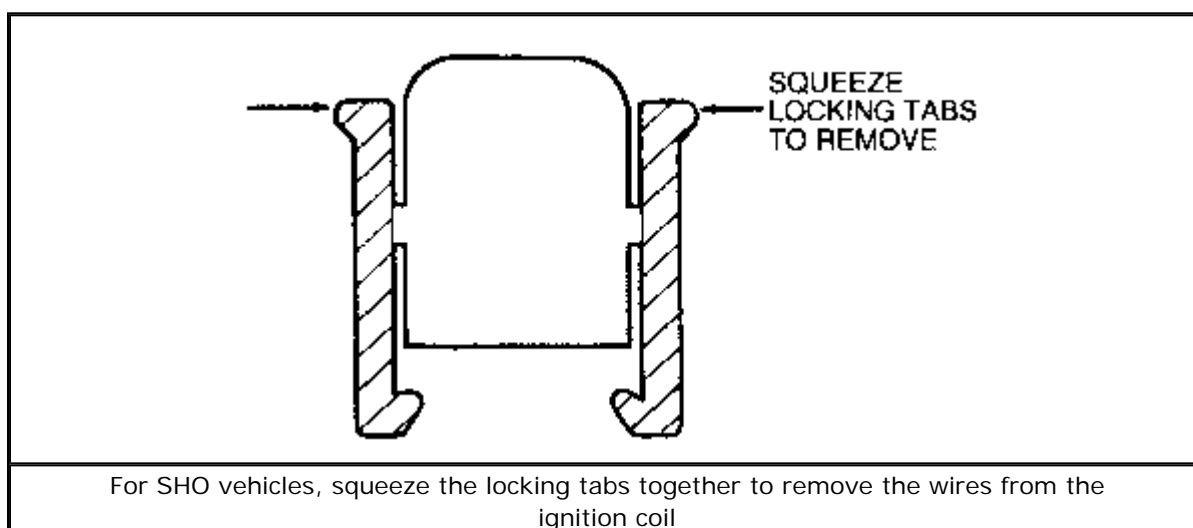
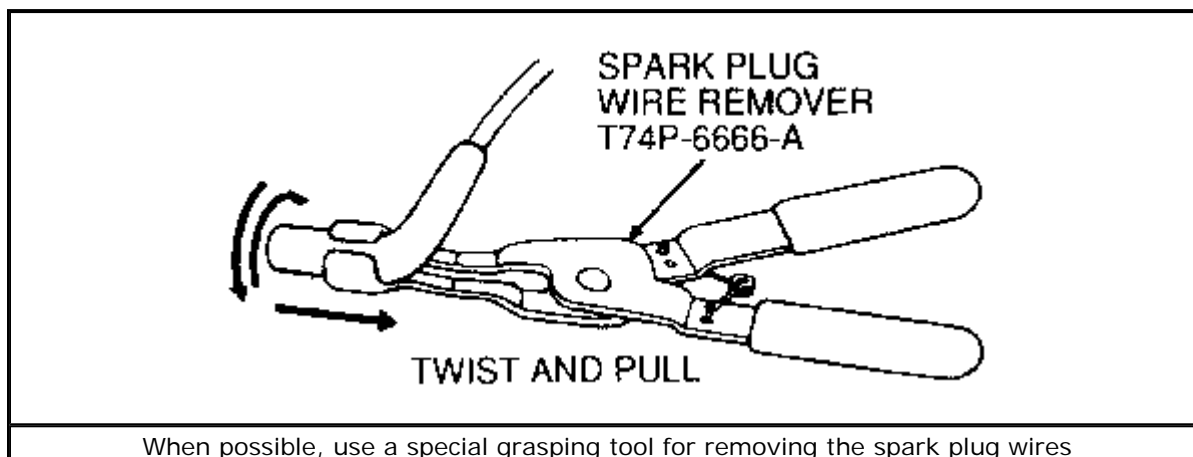

Always coat the terminals of any wire that is removed or replaced with a thin layer of silicone dielectric compound (D7AZ-19A331-A or equivalent).

When installing a wire, be sure it is firmly mounted over or on the plug, distributor cap connector or coil terminal.

Every 30,000-45,000 miles (48,000-72,000 km), the resistance of the wires should be checked using an ohmmeter. Wires with excessive resistance will cause misfiring and may make the engine difficult to start in damp weather.

To check resistance, remove the distributor cap, leaving the wires in place. Connect one lead of an ohmmeter to an electrode within the cap; connect the other lead to the corresponding spark plug terminal (remove it from the spark plug for this test). Any wire with a resistance over 7,000 ohms per foot of wire should be replaced.

FIRING ORDERS

To aid in installation and avoid confusion, remove and tag the spark plug wires one at a time.

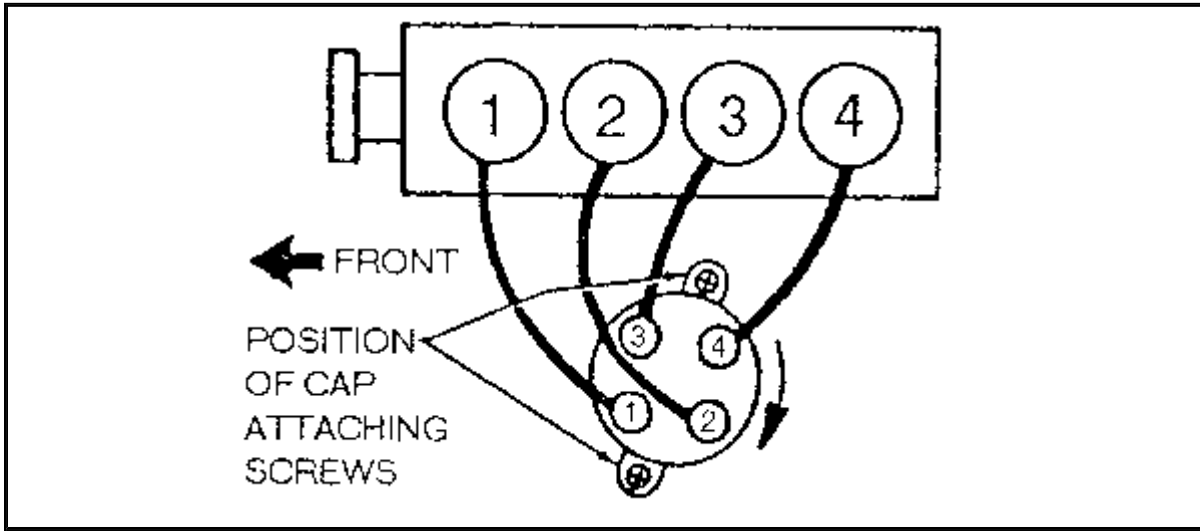

2.5L Engine Firing Order: 1-3-4-2 Distributor Rotation: Clockwise

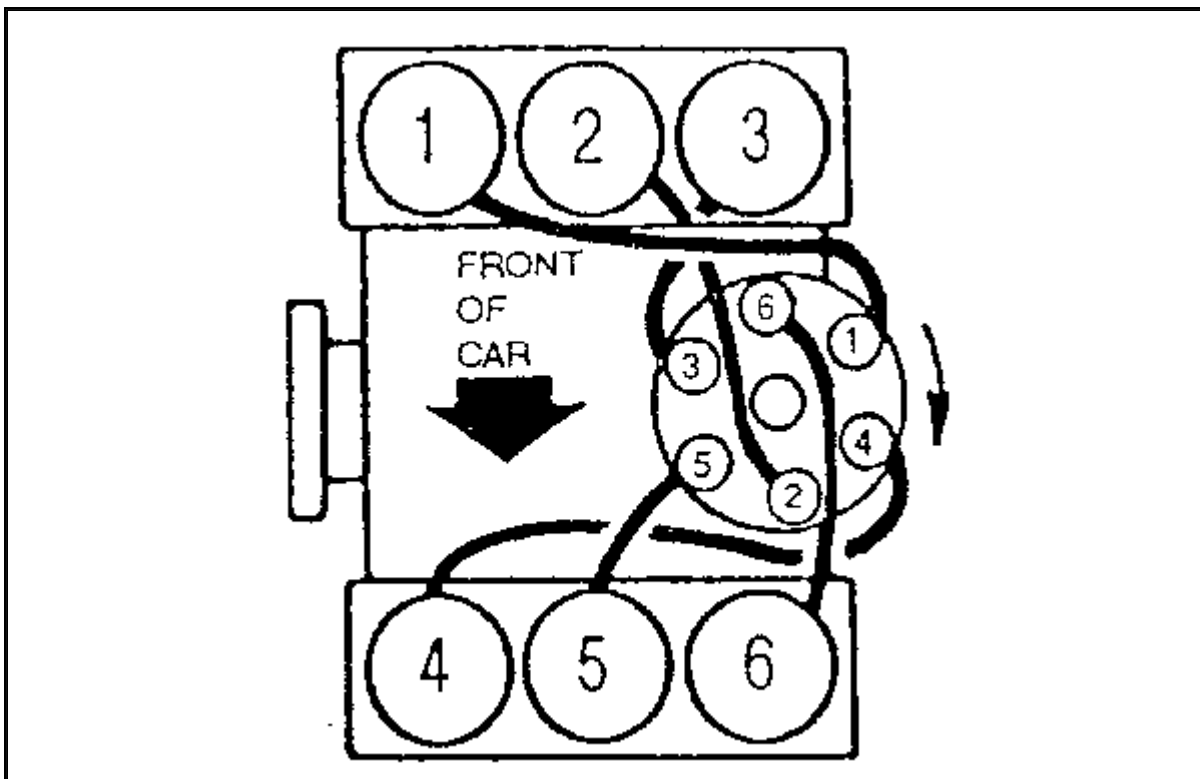

3.0L Engine-Except SHO and Flexible Fuel Firing Order: 1-4-2-5-3-6 Distributor Rotation: Clockwise

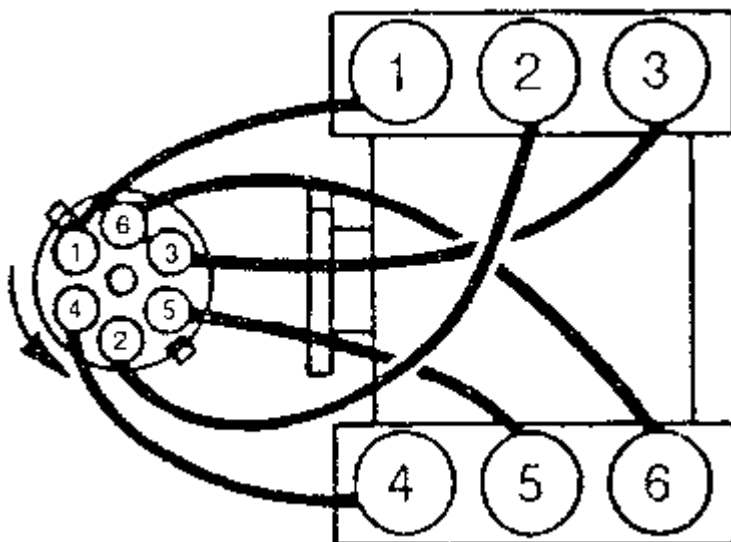

3.8L Engine Firing Order: 1-4-2-5-3-6 Distributor Rotation: Counterclockwise

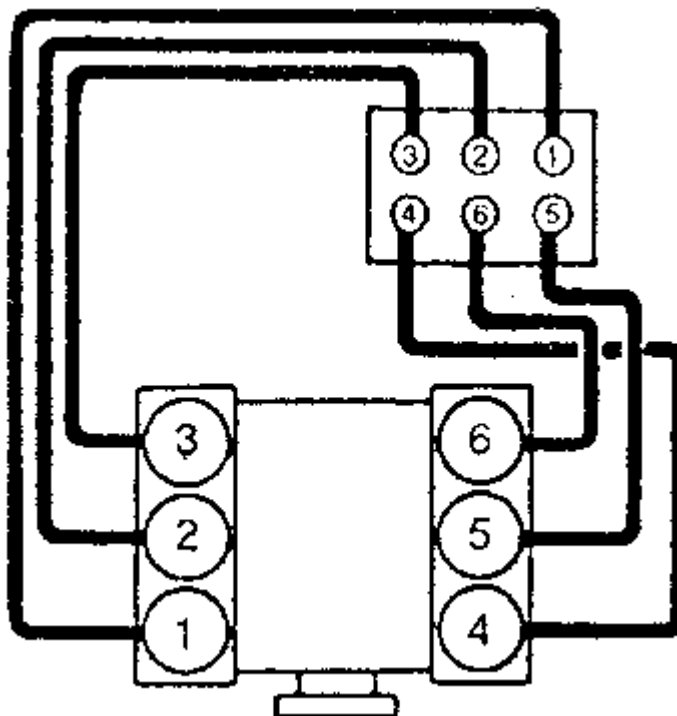

3.0L and 3.2L SHO Engines; 3.0L Flexible Fuel Engine Firing Order: 1-4-2-5-3-6
Distributorless Ignition System

DISTRIBUTOR IGNITION SYSTEM

Introduction

Your car uses one of three different electronic ignition systems. The 2.5L, 3.0L and 3.8L engines utilize the standard Distributor Ignition (DI) system. The 3.0L/3.2L SHO and the 3.0L Flexible Fuel (FF) engines use two different Electronic Ignition (EI) systems, formerly known as Distributorless Ignition (DIS). The purpose of using an electronic ignition system is to eliminate the deterioration of spark quality which occurred in the earlier breaker point ignition system as the breaker points wore, to extend maintenance intervals, and to provide a more intense and reliable spark at every firing impulse, in order to ignite the leaner gas mixtures necessary to control emissions.

Description & Operation

Taurus and Sable models equipped with the 2.5L, 3.0L, and 3.8L engines incorporate an ignition system using a Universal Distributor. The ignition system includes:

- **A universal distributor that has a diecast housing with a Hall effect distributor stator.**
- **An "E" type ignition coil which transforms battery voltage on the primary circuit, into about 28,000 volts on the secondary circuit each time the ignition coil receives a signal from the Ignition Control Module (ICM).**
- **An ignition control module which features EEC-IV or PCM-controlled ignition coil charge times.**

Some of the earlier models are equipped with a TFI-IV module. TFI stands for Thick Film Integrated and incorporates a molded thermoplastic module mounted on the distributor base. In later systems, the TFI-IV module's functions are carried out by the ignition control module.

In this system, the distributor is driven off the camshaft and uses no centrifugal or vacuum advance. The distributor operates by using a Hall effect vane switch assembly, causing the ignition coil to be switched on and off by the EEC-IV and TFI-IV modules on earlier vehicles, or the Powertrain Control Module (PCM) and the Ignition Control Module (ICM) on later vehicles.



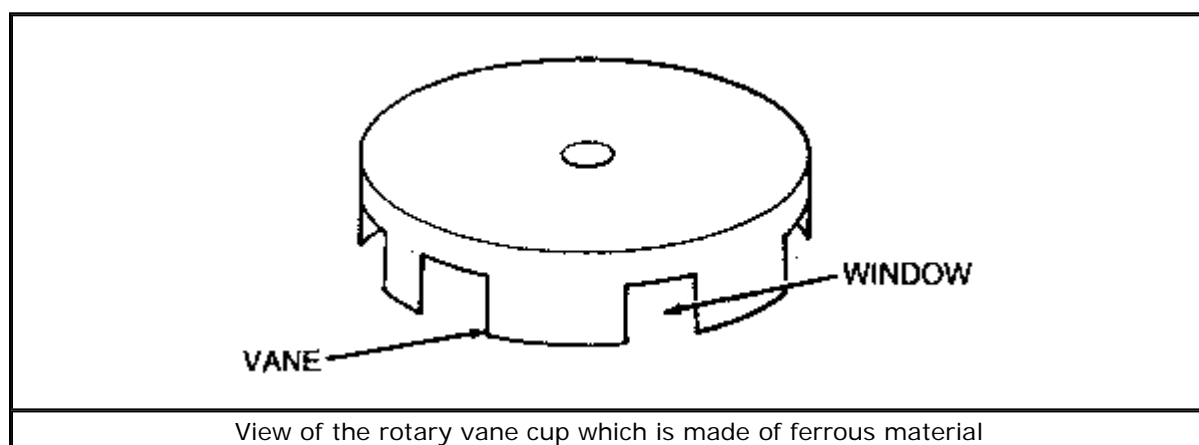
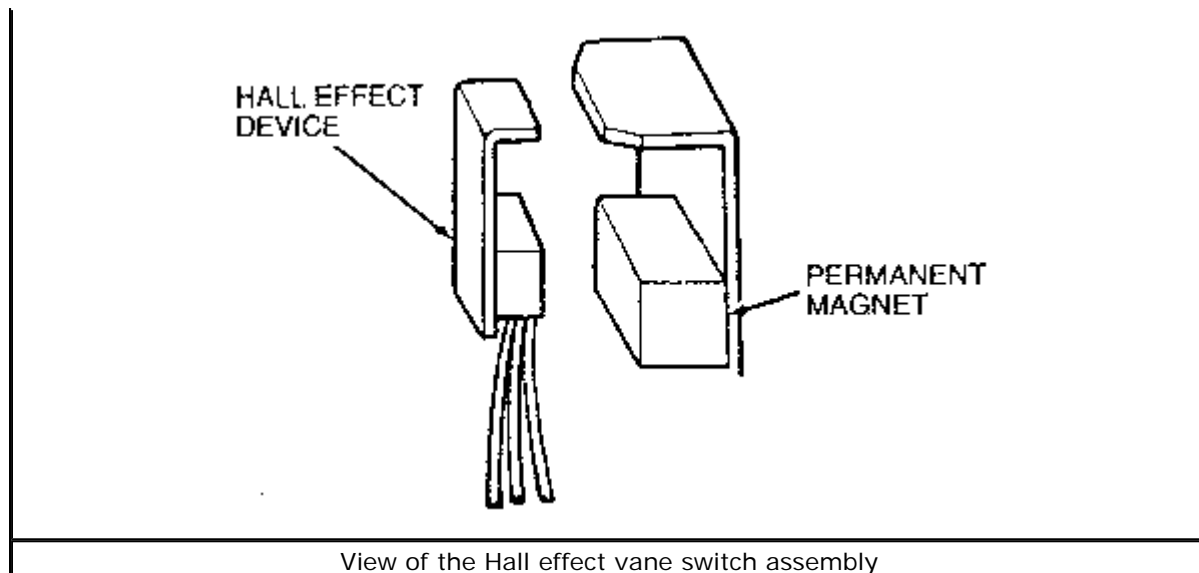

The vane switch is an encapsulated package consisting of a Hall sensor on one side and a permanent magnet on the other side. A rotary vane cup, made of ferrous material, is used to trigger the signal OFF and ON. When the window of the vane cup is between the magnet and the Hall effect device, a magnetic flux field is completed from the magnet through the Hall effect device and back to the magnet. As the vane passes through this opening, the flux lines are shunted through the vane and back to the magnet. During this time, a voltage is produced as the vane passes through the opening. When the vane clears the opening, the window edge causes the signal to go to zero volts. The signal is then used by the EEC-IV or PCM (as applicable) for crankshaft position sensing and the computation of the desired spark advance based on engine demand and calibration. The voltage distribution is accomplished through a conventional rotor, cap and ignition wires.

Component Testing

IGNITION COIL

1. Follow the coil wire from the center terminal on the distributor cap to the end at the ignition coil. Make sure the transaxle is in Park (AT) or Neutral (MT) and that the ignition is turned OFF.
2. Separate the wiring harness connector from the ignition module at the distributor. Inspect for dirt, corrosion and damage. Reconnect the harness if no problems are found.

Push the connector tabs together to separate.

3. Attach a 12 volt DC test light between the coil Tach terminal and an engine ground, then crank the engine. If the light flashes or is continuous:
 1. Turn the ignition switch OFF.
 2. Disengage the ignition coil connector on top of the coil and inspect for dirt, corrosion and/or damage.
 3. Using an ohmmeter, measure the ignition coil primary resistance from the positive (+) to the negative (-) terminal of the ignition coil. See the corresponding figures for terminal locations.
 4. The ohmmeter reading should be 0.3-1.0 ohms. If the reading is less than 0.3 ohms or greater than 1.0 ohms, the ignition coil should be replaced.
 5. Using an ohmmeter, measure the coil secondary resistance; connect it to the negative (-) terminal and the high voltage terminal.
 6. The resistance should be 6,500-11,500 ohms with the ohmmeter set on ohms x 1000. If the reading is less than 6,500 ohms or greater than 11,500 ohms, replace the ignition coil.

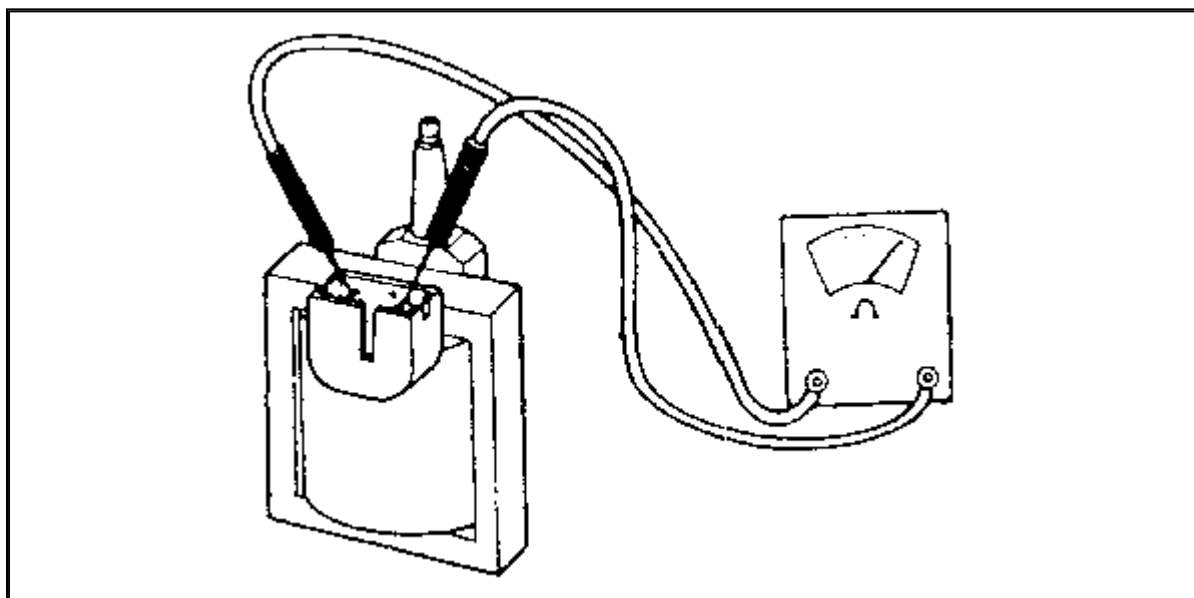

Testing ignition coil primary resistance

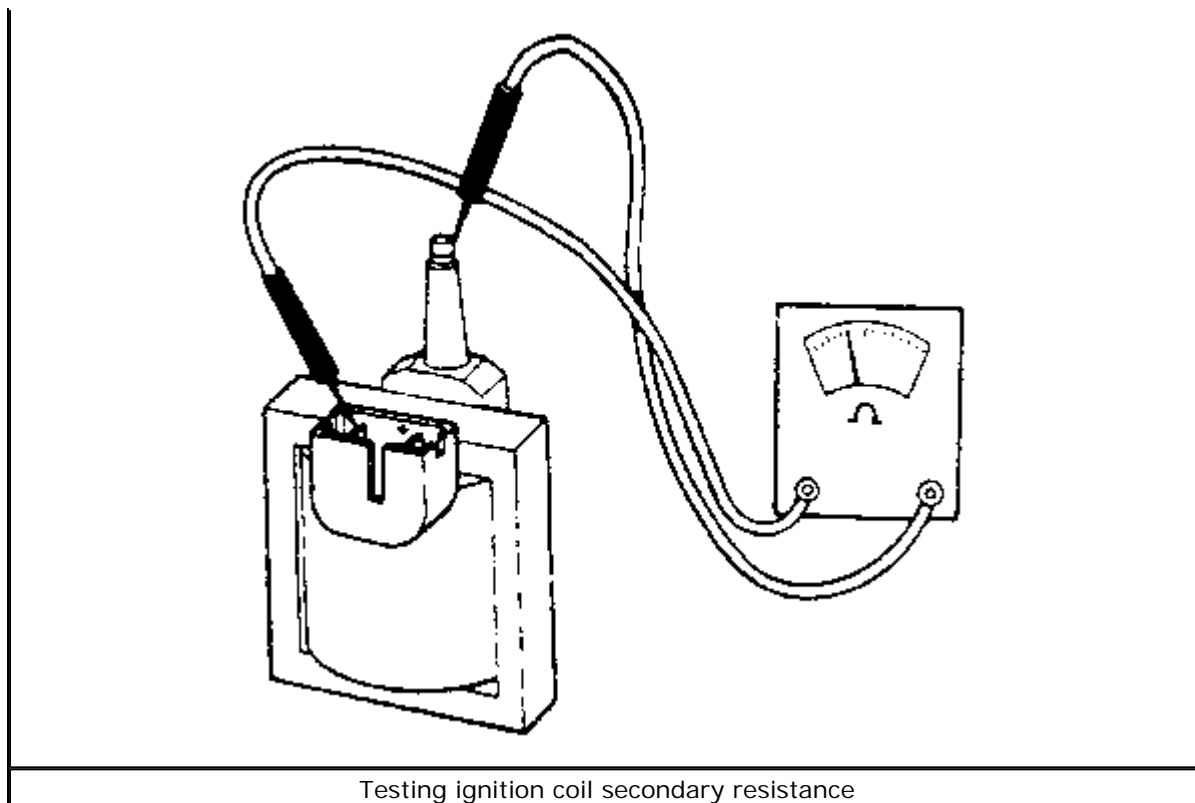

Testing ignition coil secondary resistance

Component Replacement

REMOVAL & INSTALLATION

Distributor Cap and Rotor

1. Disconnect the negative battery cable.
2. If equipped, remove the distributor cap cover, then disengage the electrical connector, if applicable.

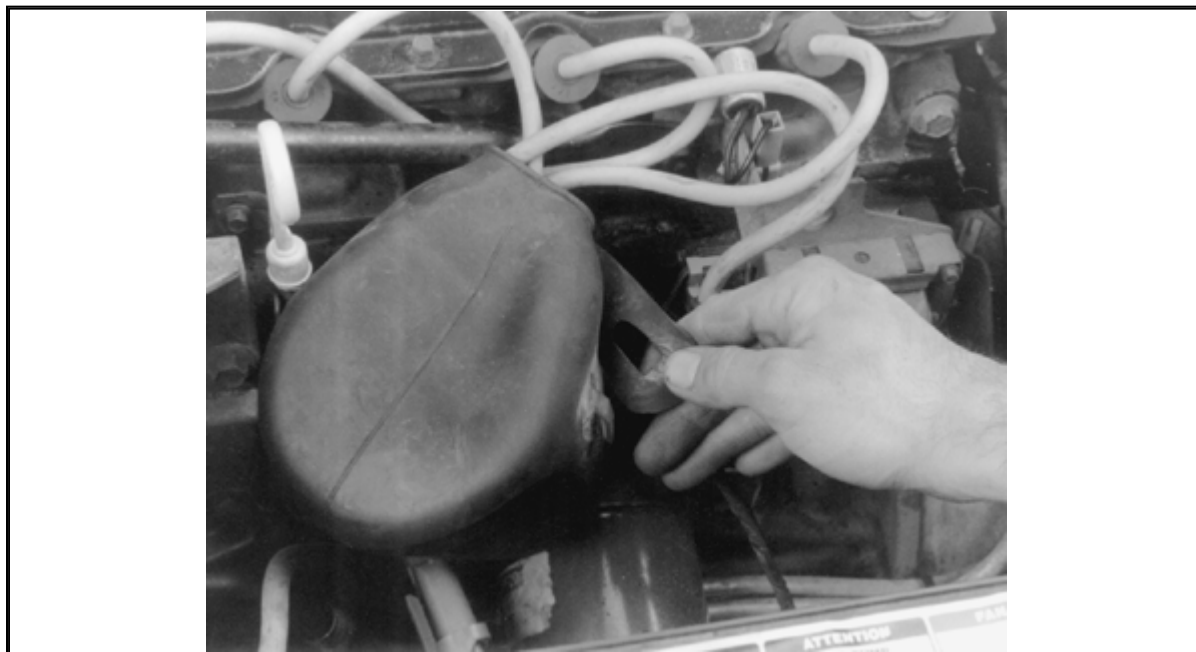

If equipped, remove the distributor cap cover



Disengage the electrical connector

3. If necessary, tag and remove the spark plug wires from the cap.
4. Loosen the distributor hold-down screws.
5. Remove the distributor cap by lifting it straight off the distributor to prevent damage to the rotor blade and spring.

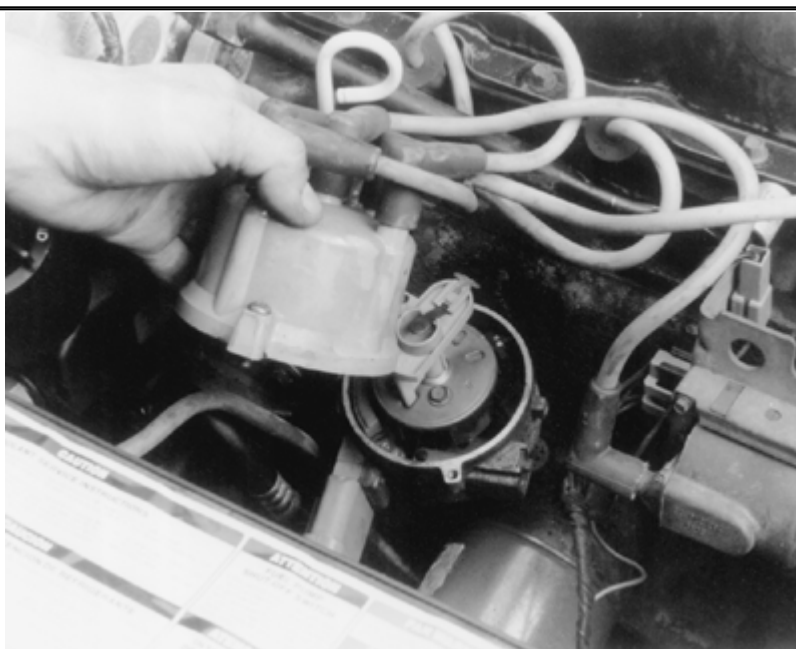

Lift the distributor cap straight up to prevent damage to the rotor blade and spring

6. Matchmark the position of the rotor, then pull it upward to remove it from the distributor shaft and armature.

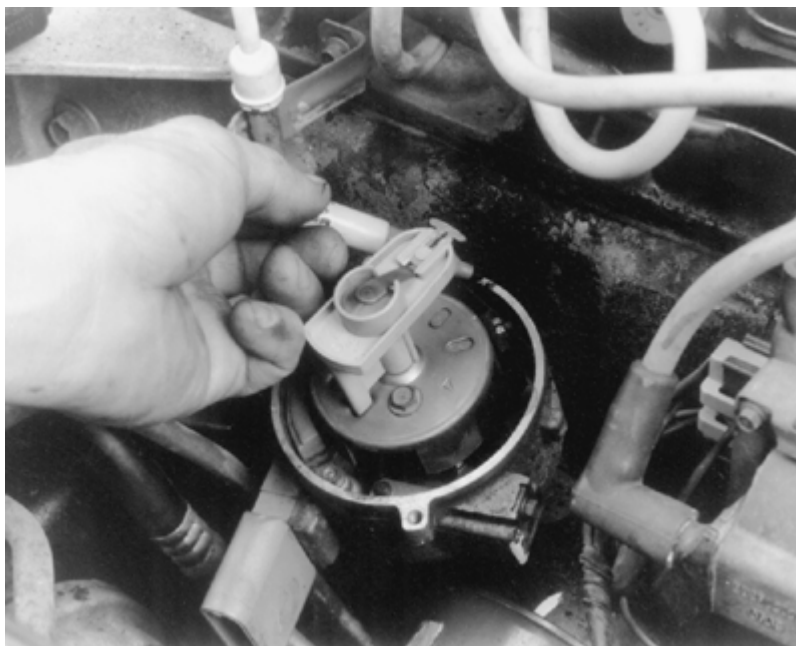

Matchmark the position of the rotor for installation purposes

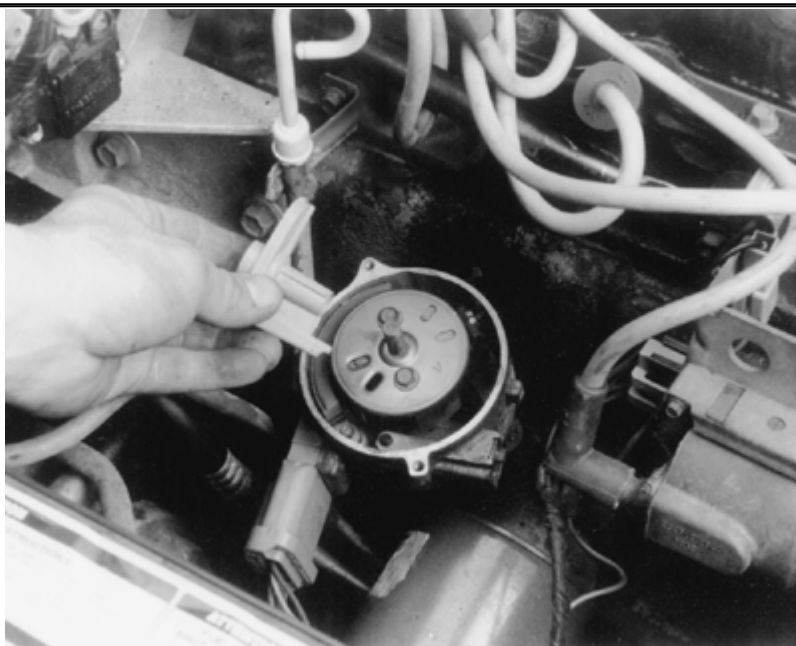

Pull the rotor upward to remove it from the distributor shaft and armature

To install:

7. Install the rotor according to the marks made during removal, making sure to align the locating boss on the rotor with the hole on the armature, then fully seat the rotor on the distributor shaft.

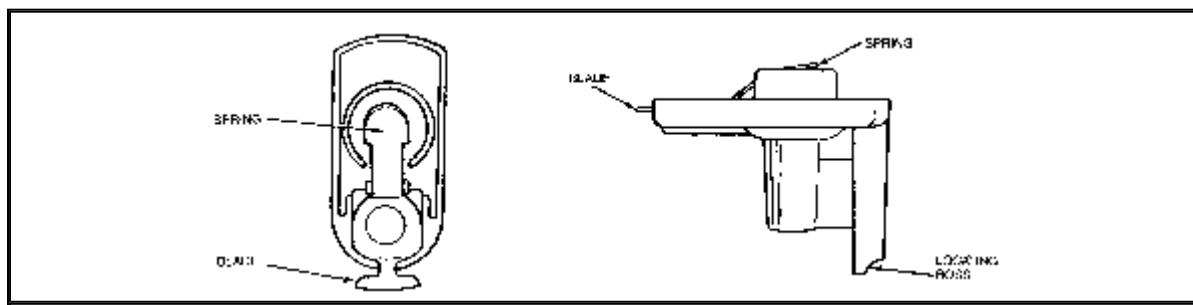

View of the spring, blade and the locating boss on the rotor

[Click to enlarge](#)

8. Position the distributor cap on the housing, noting the square alignment locator, if equipped. Tighten the hold-down screws to 18-23 inch lbs. (2.0-2.6 Nm).

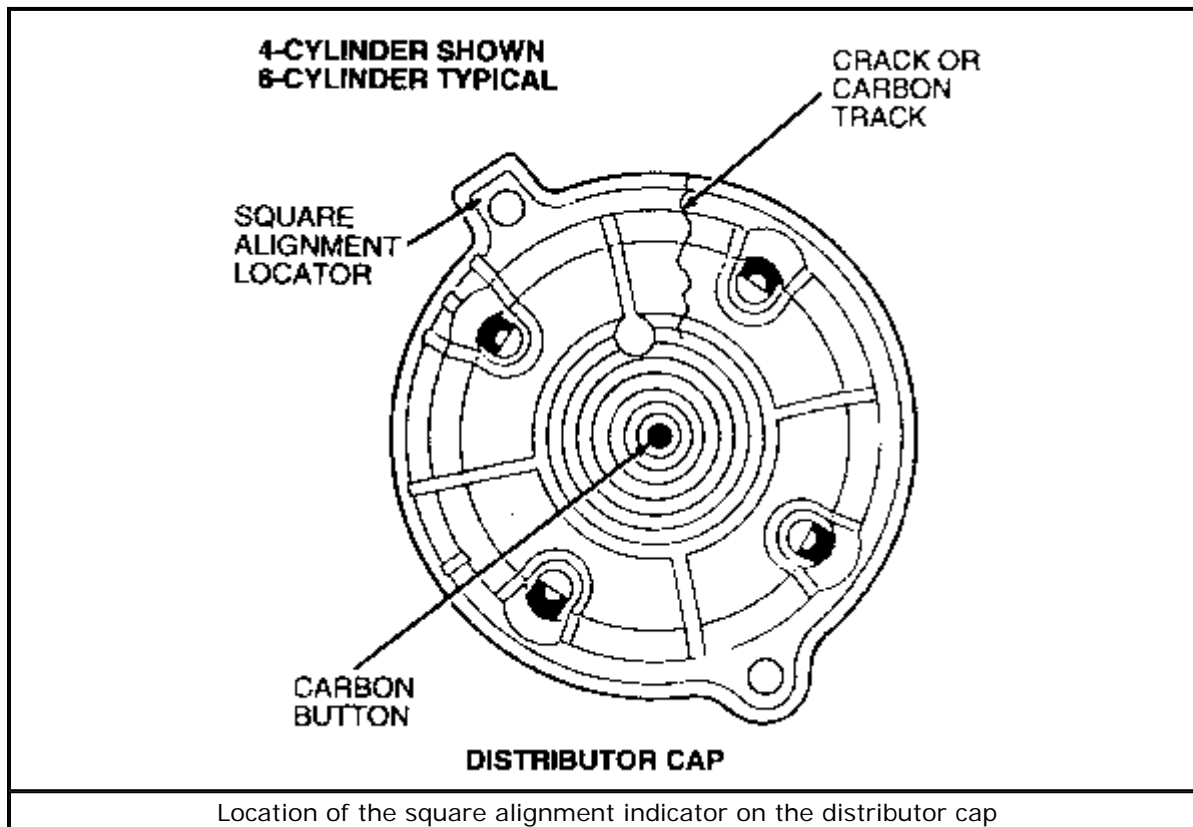

[Click to enlarge](#)

9. If removed, connect the spark plug wires to their correct location on the distributor cap as tagged during removal.
10. If equipped, install the distributor cap cover, then connect the negative battery cable.

Ignition Coil

1. Disconnect the negative battery cable.
2. Disconnect the distributor-to-ignition coil wire from the ignition coil.

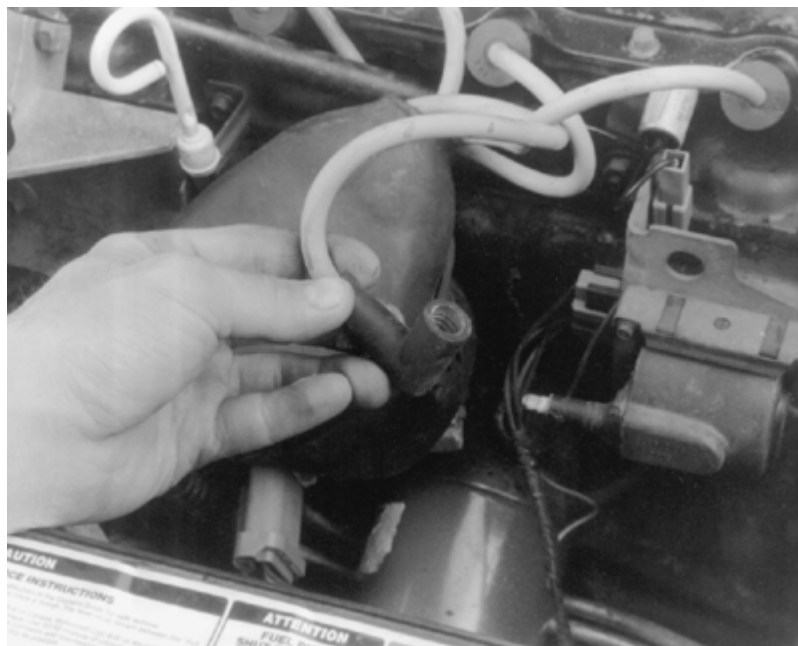

Disconnect the distributor-to-ignition coil wire-early model 2.5L shown

3. **Disengage the TFI-IV harness or the engine control sensor wiring connector from the ignition coil, as applicable.**

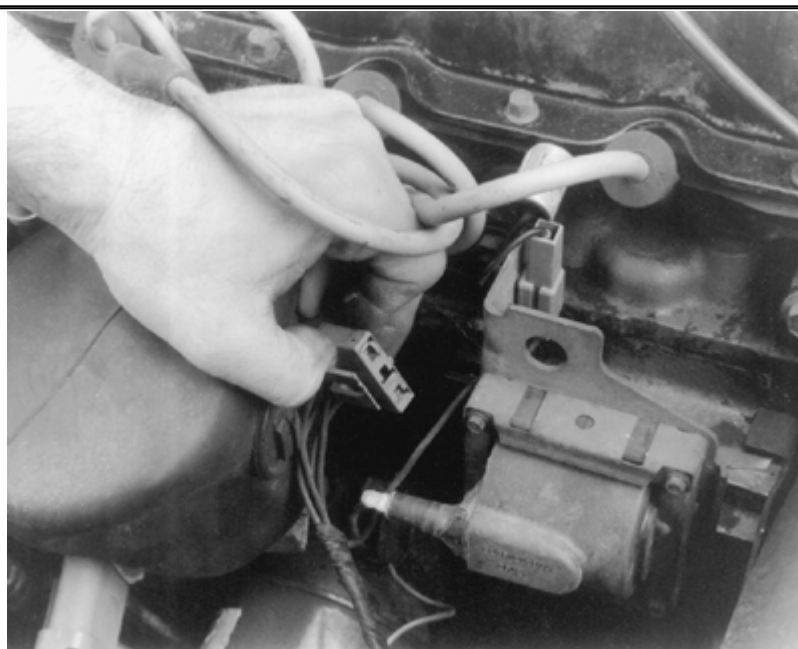

Disengage the engine wiring connector from the coil-early model 2.5L shown

4. **On the 3.8L engine, disengage the engine control wiring connector from the radio ignition interference capacitor.**
5. **Remove the ignition coil retaining screws and the ignition coil and radio interference capacitor (if equipped) from the ignition coil mounting bracket.**

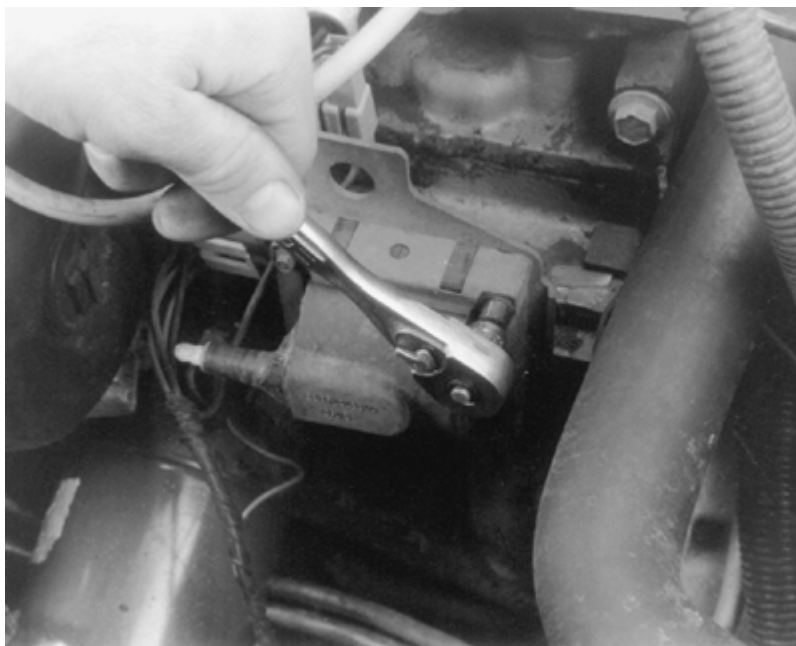

Remove the ignition coil retaining screws

6. Remove the ignition coil cover from the ignition coil by releasing the locking tabs on both sides of the cover, then remove the ignition coil.

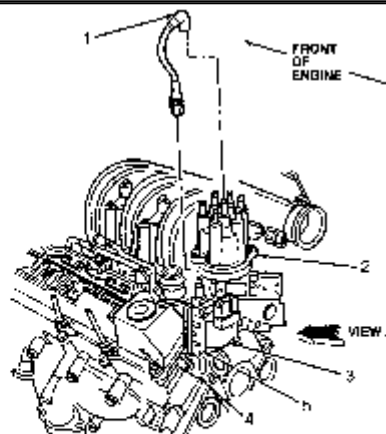
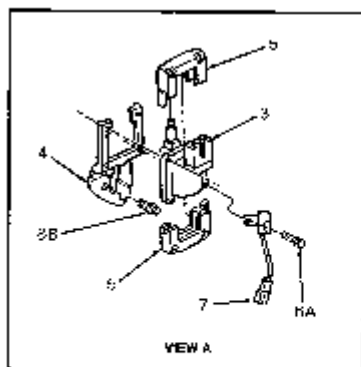

- 1 Ignition coil to distributor high tension wiring
- 2 Distributor cap
- 3 Ignition coil
- 4 Ignition coil mounting bracket
- 6 Ignition coil cover

- 8A Screw (4 req'd)
- 7 Radio ignition interference capacitor
- 8B Bolt (2 req'd)
- A Tighten to 2.3-4.0 Nm (20-35 lb.in.)
- B Tighten to 20-30 Nm (15-22 lb.ft.)

Ignition coil and related components-late model 3.0L shown

[Click to enlarge](#)

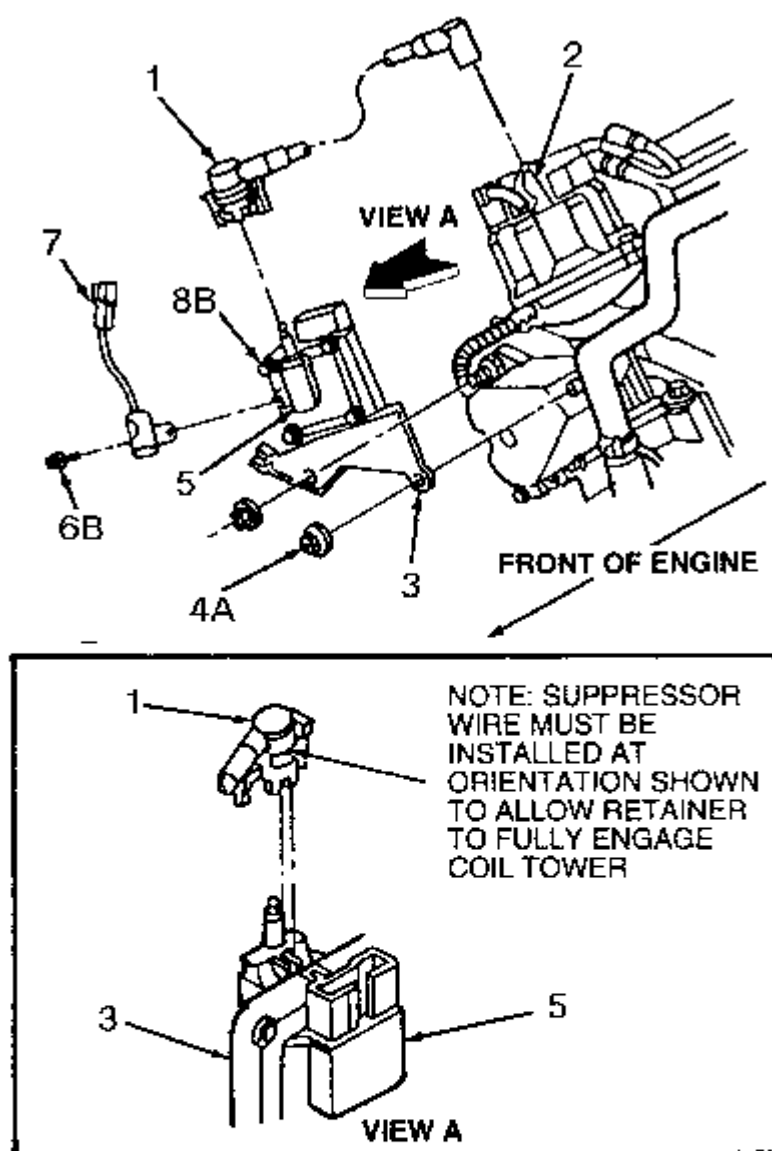

- 1 Ignition coil to distributor high tension wiring
- 2 Distributor cap
- 3 Ignition coil mounting bracket
- 4A Nut (2 req'd)
- 5 Ignition coil
- 6B Screw
- 7 Radio ignition interference capacitor
- 8B Screw (4 req'd)
- A Tighten to 40-50 Nm (30-41 lb.ft.)
- B Tighten to 2.8-4.0 Nm (25-35 lb.in.)

Ignition coil and related components-late model 3.8L shown

[Click to enlarge](#)

To install:

7. Install the ignition coil, then attach ignition coil cover, making sure the cover is firmly in place.
8. If removed, connect the ignition coil and radio interference capacitor, then install the ignition coil retaining screws. Tighten the retaining screws to 25-35 inch lbs. (2.8-4.0 Nm).
9. Connect the coil wire, then engage any electrical connectors that were removed.
10. Connect the negative battery cable.

Ignition Control Module (ICM)

In earlier models, the ICM was referred to as the TFI-IV Ignition Module; the name was later changed to Ignition Control Module (ICM).

2.5L AND 3.0L ENGINES

1. Remove the distributor cap and position it away from the work area, with the wires still attached.
2. Disengage the engine control sensor wiring connector (late model vehicles) or the TFI-IV harness connector from the ignition control module.
3. Remove the distributor from the engine. For details, please refer to the procedure located later in this section.
4. Place the distributor on a work bench, then remove the two module retaining screws.

Do NOT attempt to lift the module from the mounting surface before moving the entire module toward the distributor flange! This will cause the pins to break at the distributor/module connector.

5. Pull the right-hand side of the module down toward the distributor mounting flange and back up to disengage the module terminals from the connector in the distributor housing. The module may then be pulled toward the flange and away from the distributor.
6. Remove the module from the distributor.

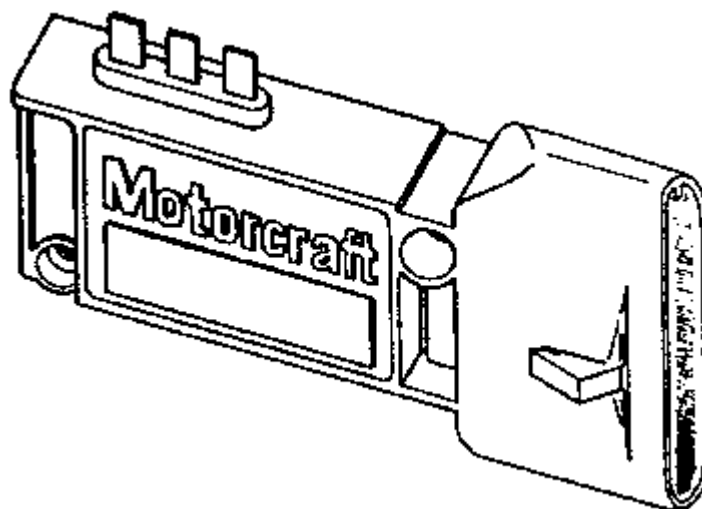

The ignition control module (or TFI ignition module, as applicable), is located on the distributor

To install:

7. Coat the metal base of the module with Silicone Dielectric Compound D7AZ-19A331-A, or equivalent meeting Ford specifications, approximately $\frac{1}{32}$ in. (0.79mm) thick.
8. Place the module on the distributor housing mounting flange.
9. Carefully position the module toward the distributor housing, then align the three distributor connecting pins.
10. Install the two module retaining screws, then starting with the upper right-hand screw, tighten the screws to 15-35 inch lbs. (1.7-4.0 Nm).
11. Install the distributor as explained later in this section.
12. Install the distributor cap, then tighten the mounting screws to 18-23 inch lbs. (2.0-2.6 Nm).
13. Engage the engine control sensor wiring connector or TFI-IV harness connector, as applicable, to the module.
14. Connect the negative battery cable.
15. Using an inductive timing light, check the timing and adjust as necessary. This procedure is covered later in this section.

3.8L ENGINE

1. Disconnect the negative battery cable.
2. Remove the screws attaching the cowl vent screen to the top of the cowl.
3. Separate the engine compartment cowl seal strip from the cowl vent screen and the cowl dash extension panel in the area of the ignition control module.
4. Lift the cowl vent screen off to allow access to the ignition control module/TFI module assembly.

The connector latch is underneath the ICM/TFI shroud. Press upward to unlatch.

5. Disengage the engine control sensor wiring connector from the ICM or TFI, as applicable.

The ignition control module and heatsink are mounted with the heatsink fins pointed downward.

6. Remove the two retaining nuts attaching the ICM/TFI and heatsink to the dash panel, then remove the ICM/TFI and the heatsink.
7. Remove the two module retaining screws, then remove the ICM or TFI from the heatsink.
8. While holding the module connector shroud with one hand, pull the seal off the other end of the module.



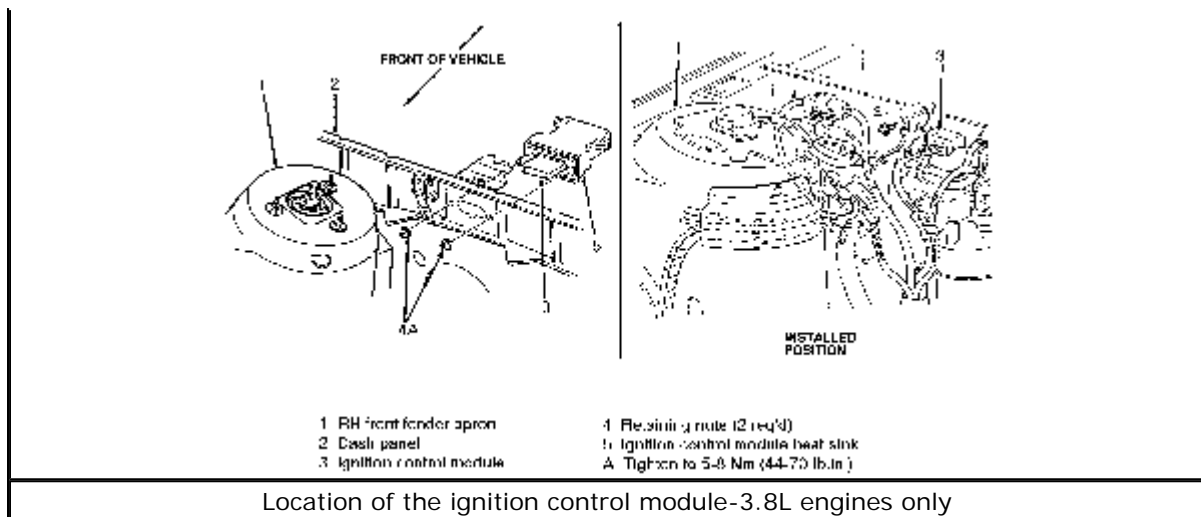

[Click to enlarge](#)

To install:

9. Coat the metal base of the ICM or TFI module uniformly with Silicone Dielectric Compound D7AZ-19A331-A or equivalent, about $1/32$ in. (0.79mm) thick.
10. Place the module onto the heatsink. Install the retaining screws, then tighten them to 15-35 inch lbs. (1.7-4.0 Nm).
11. Push the seal over the module connector shroud and heatsink studs with the metal part toward the heatsink.
12. Insert the module and heatsink into the cowl dash extension panel enough to have the mounting studs protrude into the engine compartment side.
13. Hand-tighten the retaining nuts to 44-70 inch lbs. (5-8 Nm).
14. Engage the engine control sensor wiring connector to the module.
15. Install the cowl vent screen and retaining screws, then install the engine compartment cowl panel and seal strip.
16. Connect the negative battery cable.

Distributor

1. Disconnect the negative battery cable.
2. Disconnect the engine control sensor wiring from the distributor.
3. With a marker, chalk or crayon, mark the position of the No. 1 cylinder distributor cap wire tower on the distributor housing for installation reference.
4. Loosen the distributor cap hold-down screws, then pull the cap straight up and off the distributor to prevent damage to the distributor rotor blade and spring.
5. Position the distributor cap with the ignition wires intact, out of the way.

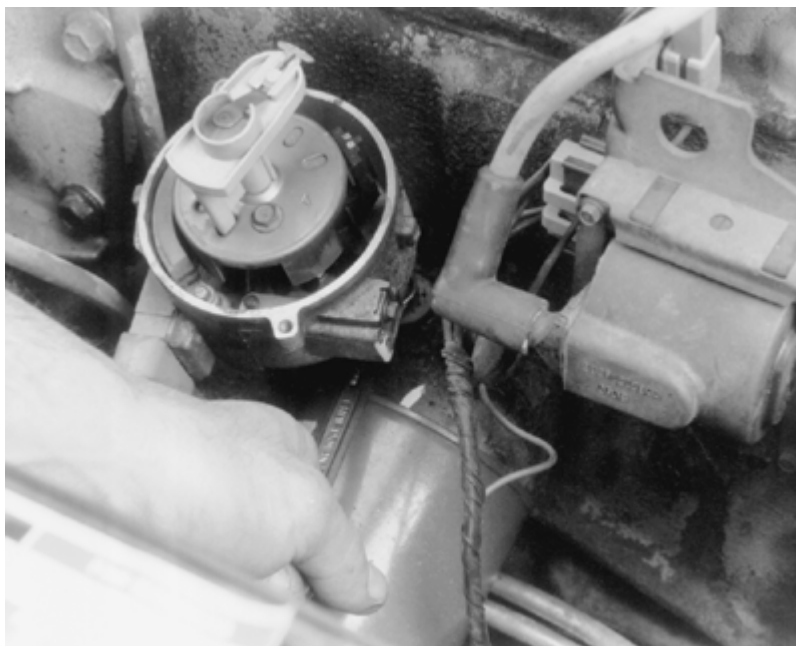

Position the cap with the wires intact out of the way for ease of removal

6. **Matchmark the position of the rotor, then remove it by pulling it upward from the distributor shaft and armature.**
7. **Disconnect the hold-down clamp and distributor retaining bolt, then remove the distributor from the engine by pulling it upward.**

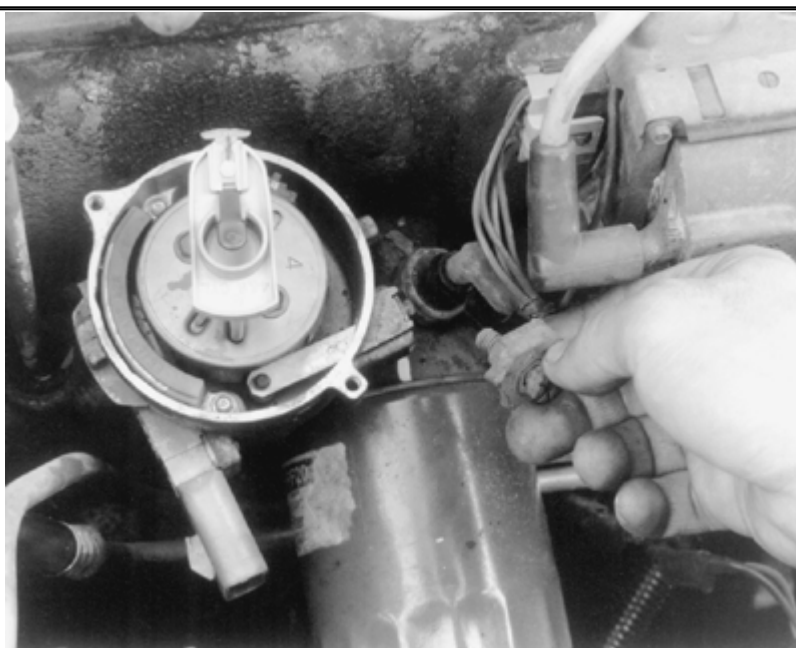

Removing the distributor hold-down bolt. Note: The preferred method requires the removal of the rotor when removing the distributor.

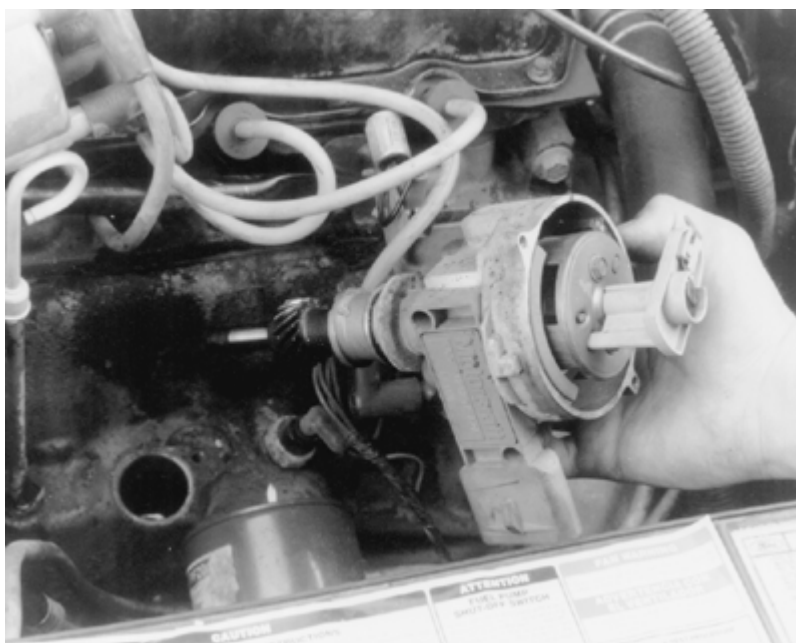

Lift the distributor from the engine; once the distributor is lifted partly out it, may be tilted slightly and removed

- 8. Cover the distributor opening in the cylinder block or engine front cover, as applicable, with a clean rag to prevent any foreign material or debris from entering the engine.**

To install:

CAUTION

Before installing the distributor, you must coat the entire drive gear and the camshaft distributor gear through the distributor hole with Engine Assembly Lubricant D9AZ-19579-D or equivalent.

Inspect the distributor before installing it. Inspect the O-ring. It should fit tightly and NOT have any cuts. The distributor drive gear should be free of nicks, cracks and excessive wear. When rotated, the distributor should move freely, without binding.

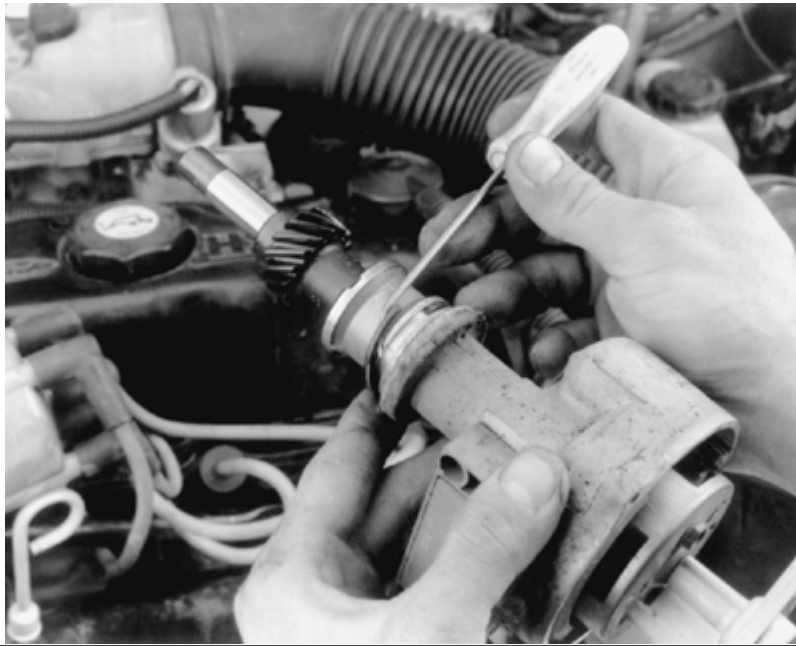

If the O-ring is cracked or nicked, it must be replaced

TIMING NOT DISTURBED

This condition exists if the engine has not been rotated while the distributor was removed.

1. **Install the distributor and the rotor, aligning the distributor housing and the rotor with the marks made during removal.**
2. **Install the distributor hold-down bolt and clamp. Only snug the bolt at this time.**
3. **Connect the wiring harness to the distributor.**
4. **Install the rotor and the distributor cap. Make sure the ignition wires are securely connected to the distributor cap and spark plugs. Tighten the distributor cap screws to 18-23 inch lbs. (2.0-2.6 Nm).**
5. **Connect a suitable timing light to the engine (following the manufacturer's instructions) and connect the negative battery cable, then start the engine and set the initial timing. Timing procedures are located later in this section.**
6. **Turn the engine OFF, then tighten the distributor hold-down bolt to 17-25 ft. lbs. (23-34 Nm) on the 2.5L engine, 14-21 ft. lbs. (19-28 Nm) on the 3.0L engine, or 20-29 ft. lbs. (27-39 Nm) on the 3.8L engine.**
7. **Start the engine and recheck the timing to verify it did not change while tightening the hold-down bolt, then stop the engine and remove the timing light.**



After the distributor is installed, check the timing with a timing light

TIMING DISTURBED

This condition exists if the engine has been rotated with the distributor removed. To correctly install the distributor, the No. 1 piston must be at TDC of the compression stroke.

1. **Disconnect the spark plug wire and the spark plug from the No. 1 cylinder.**
2. **Place your finger over the spark plug hole, then rotate the engine clockwise (by turning the crankshaft pulley) until compression is felt at the spark plug hole.**
3. **With the No. 1 piston on the compression stroke, align the timing pointer with the TDC mark on the crankshaft damper.**
4. **Align the locating boss on the rotor with the hole on the armature. Install the rotor on the distributor shaft, making sure it is fully seated on the distributor shaft. Rotate the shaft so the rotor tip is pointing toward the distributor cap's No. 1 spark plug tower position.**
5. **While installing the distributor, continue turning the rotor slightly, so the leading edge of the vane is centered in the distributor stator assembly.**
6. **Rotate the distributor in the block to align the leading edge of the vane and distributor stator assembly. Make sure the rotor is pointing toward the distributor cap No. 1 spark plug tower position.**

If the vane and distributor stator cannot be aligned by rotating the distributor in the block, remove the distributor just enough to disengage the distributor gear from the camshaft gear. Turn the rotor enough to engage the distributor gear on another tooth of the camshaft gear. Repeat this procedure, if necessary.

7. **Install the distributor hold-down bolt and clamp. Only snug the bolt at this time.**
8. **Connect the wiring harness to the distributor, then install the distributor cap. Tighten the distributor cap hold-down screws to 18-23 inch lbs. (2.0-2.6 Nm).**
9. **Install the No. 1 spark plug and wire.**
10. **Connect a suitable timing light (following the manufacturer's instructions) and**

connect the negative battery cable. Start the engine, then check and adjust the timing, as necessary.

- 11. Turn the engine OFF, then tighten the distributor hold-down bolt. Tighten the bolt to 17-25 ft. lbs. (23-34 Nm) on the 2.5L engine, 14-21 ft. lbs. (19-28 Nm) on the 3.0L engine, or 20-29 ft. lbs. (27-40 Nm) on the 3.8L engine.**
- 12. Start the engine and recheck the timing to verify it did not change while tightening the hold-down bolt, then stop the engine and remove the timing light.**

Chilton® Automotive Information Systems. © 2004 Thomson Delmar Learning.

ELECTRONIC IGNITION SYSTEMS

Description & Operation

3.0L/3.2L SHO

Tauruses with 3.0L and 3.2L SHO engines are equipped with an Electronic Ignition (EI) system previously known as the Distributorless Ignition System (DIS). As the name implies, there is no conventional distributor assembly in the engine. This system consists of:

- A Crankshaft Position sensor (CKP sensor, formerly crankshaft timing sensor) that is a single Hall effect magnetic switch, which is activated by three vanes on the crankshaft timing pulley. The signal generated by this sensor is called Crankshaft Position (CKP). The CKP signal provides base timing and crankshaft speed (rpm) information to the Ignition Control Module (ICM) and the Powertrain Control Module (PCM).

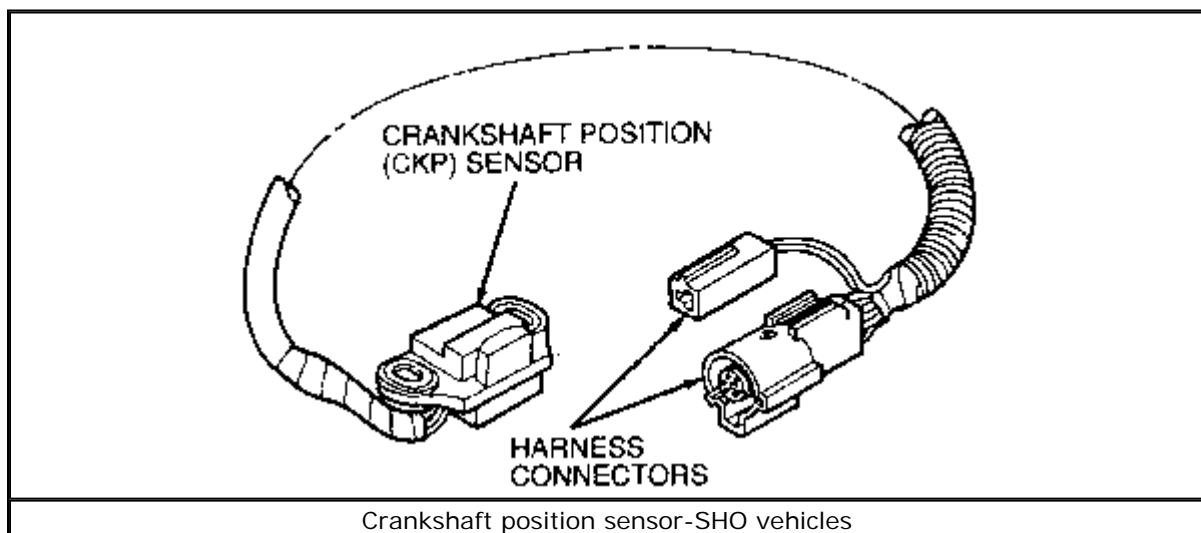

[Click to enlarge](#)

- A Camshaft Position sensor (CMP sensor) that is a single Hall effect magnetic switch also, but is activated by a single vane driven by the camshaft. This sensor provides camshaft rotational location information to the PCM. The Ignition Control Module (ICM) uses a Camshaft Position (CMP) signal for ignition coil fire sequencing. The PCM also uses the CMP signal for fuel injector synchronization.

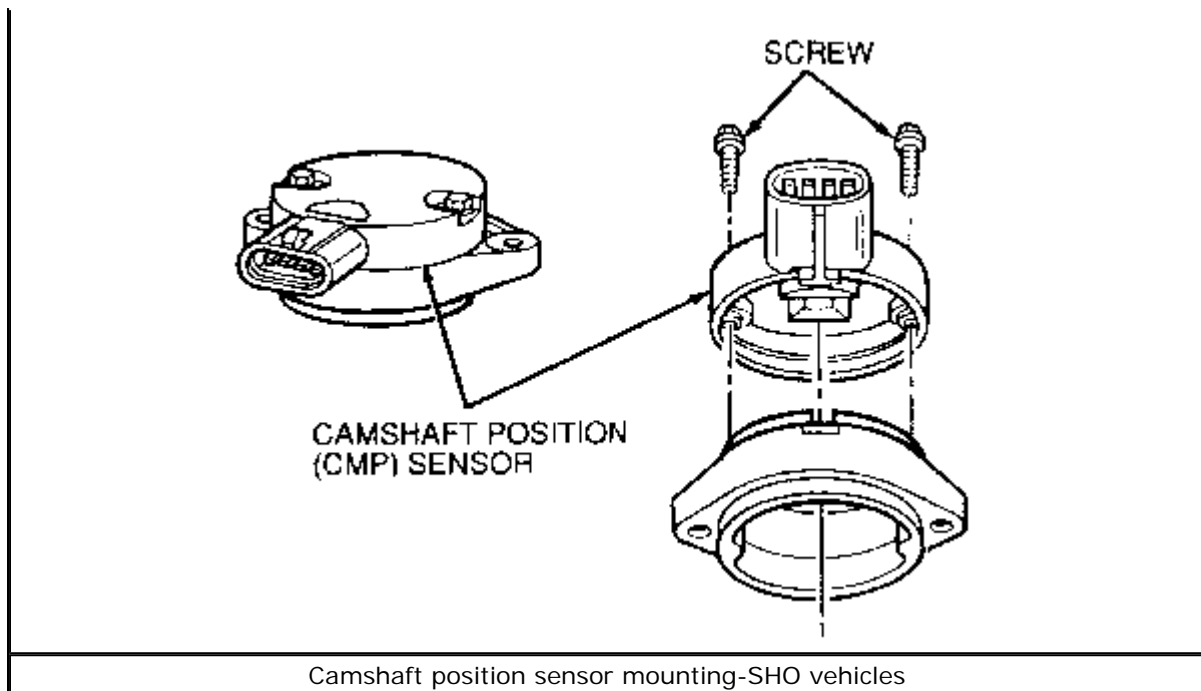

[Click to enlarge](#)

- An ignition coil that houses the spark plug wires like the conventional distributor cap. The ignition "coil" actually contains three separate ignition coils. Each coil is controlled by the Ignition Control Module (ICM) through three coil leads. Each ignition coil activates two spark plugs simultaneously, one on the compression stroke (this uses the majority of the ignition coil's energy) and one on the exhaust stroke (this uses very little of the ignition coil's stored energy).

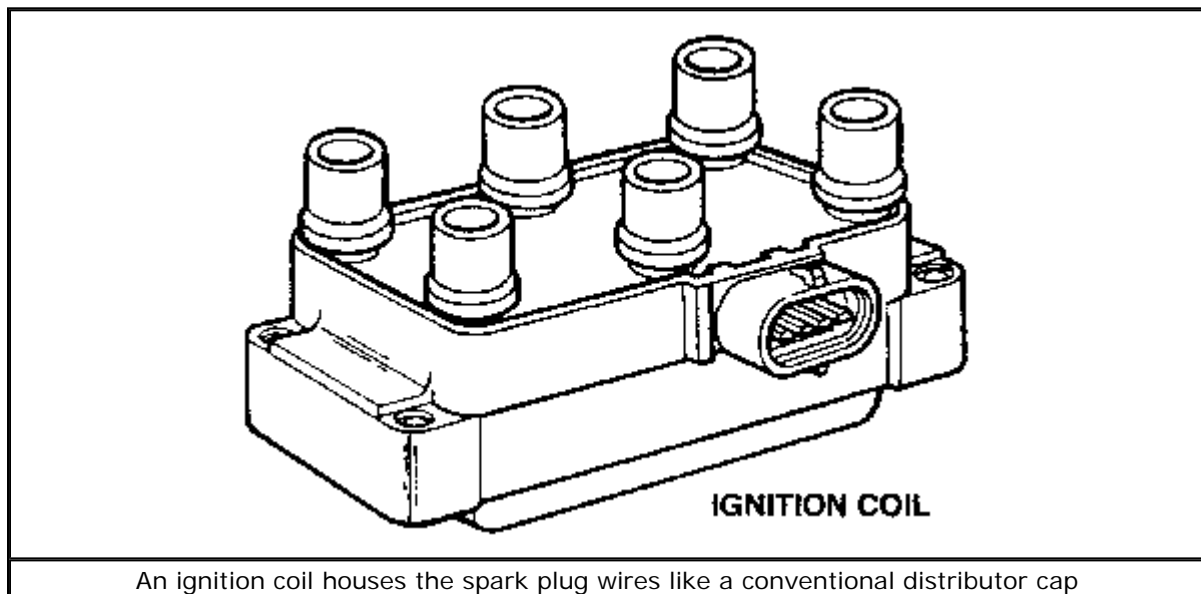

- An Ignition Control Module (ICM) which receives the CKP signal from the CKP sensor. During normal operation, the CKP signal is sent to the PCM from the CKP sensor and provides base ignition timing and RPM information. The ICM receives the CMP signal from CMP sensor, providing the ICM with the information required to synchronize the ignition coils in the proper sequence. It also receives the Spark Output (SPOUT) from the PCM. The SPOUT signal contains the optimum spark timing and dwell information.

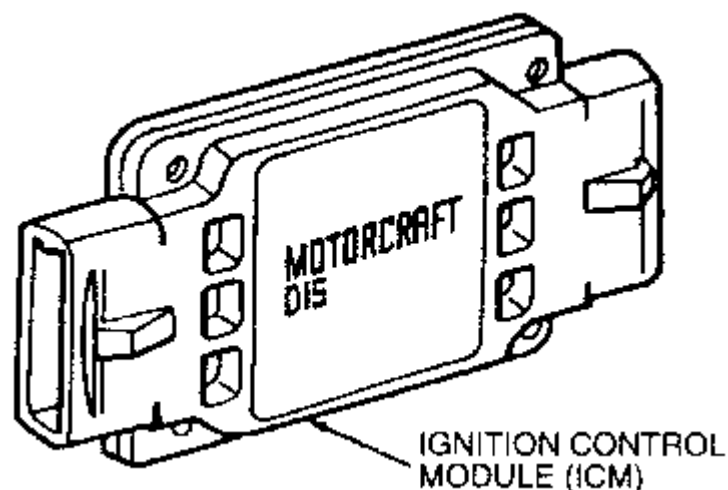

The ignition control module is mounted to the engine air inlet connector

3.0L FLEXIBLE FUEL (FF) VEHICLES

The 3.0L Flexible Fuel Taurus is equipped with an ignition system that is very similar to that of the 3.0/3.2L SHO vehicles. The main difference is the crankshaft position sensor. The system includes:

- A Crankshaft Position sensor (CKP sensor) which is a variable reluctance sensor triggered by a "36-minus-1" tooth trigger wheel located on the crankshaft pulley and damper. The signal generated from the CKP sensor is called the Crankshaft Position signal (CKP signal). This signal provides base timing and crankshaft speed (rpm) information to the Ignition Control Module (ICM). The ICM uses this information with the spark advance information from the PCM to determine ignition coil ON and OFF time.

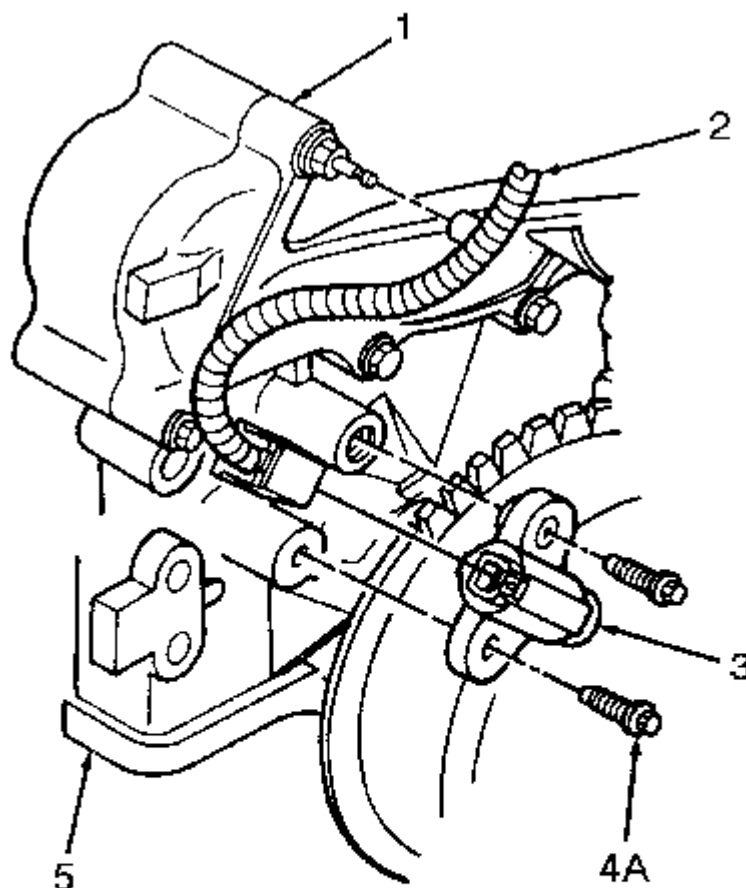

- 1 Water pump
- 2 Fuel charging wiring
- 3 Crankshaft position sensor
- 4 Bolt (2 req'd)
- 5 Engine front cover
- A Tighten to 5-7 Nm (44-61 lb.in.)

Location of the crankshaft position sensor-3.0L FF engine

[Click to enlarge](#)

- An ignition "coil" which is mounted to the rear of the left-hand cylinder head. It actually contains three separate ignition coils. Each ignition coil is controlled by the ignition control module through three coil leads. Each ignition coil activates two spark plugs simultaneously, one on the compression stroke (this plug uses the majority of the ignition coil's energy) and one on the exhaust stroke (this plug uses very little of the ignition coil's stored energy).

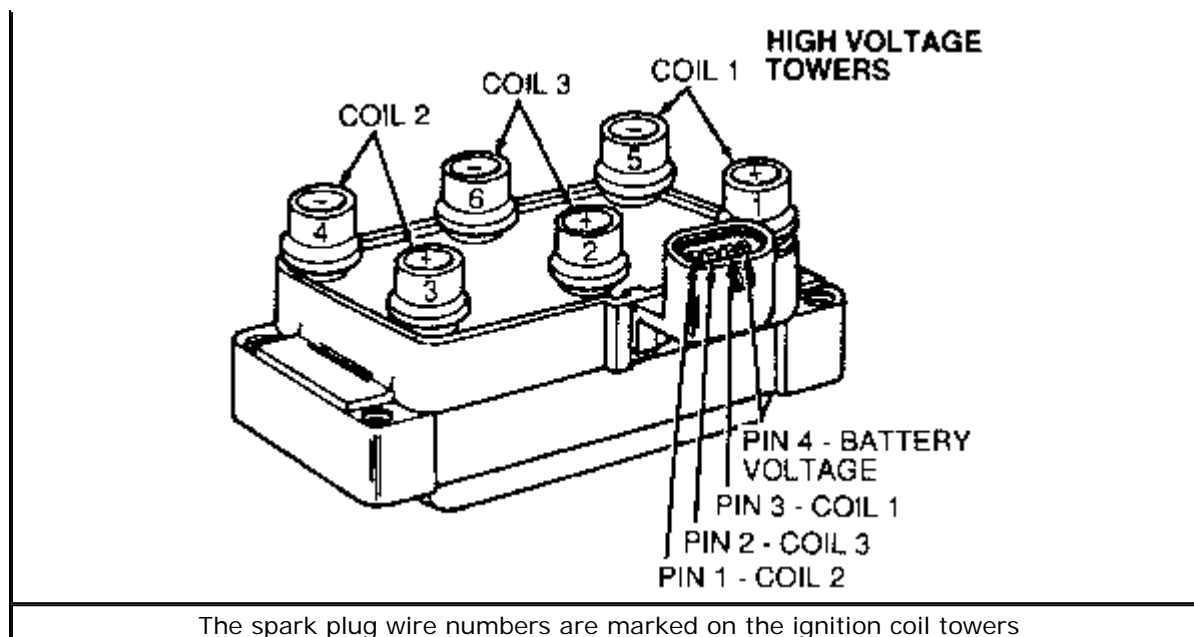

[Click to enlarge](#)

- An Ignition Coil Module (ICM) which is located on the dash panel in the engine compartment. It receives engine position and speed information from the CKP sensor, and desired spark advance information from the PCM. The ignition module uses this information to determine which ignition coil to fire, calculating the ON and OFF times of the ignition coils required to achieve the correct dwell and spark advance. It outputs a Profile Ignition Pickup (PIP) signal and an Ignition Diagnostic Monitor (IDM) signal for use by the PCM. It also sends information on system failures through the IDM signal to the PCM, stores information for use during diagnostic test mode, and provides the signal for the tachometer.

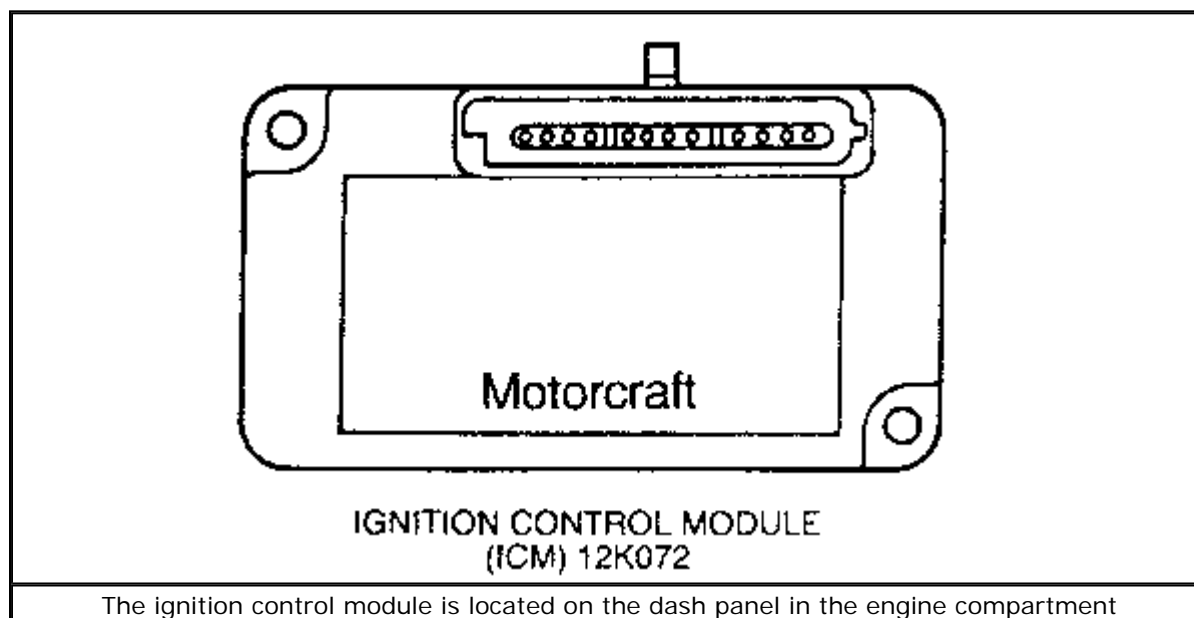

Component Replacement

3.0L/3.2L SHO VEHICLES

Crankshaft Position (CKP) Sensor

1. Disconnect the negative battery cable.
2. Loosen the drive belt tensioner for the A/C compressor and power steering drive belts.
3. Remove the drive belts from the crankshaft vibration damper and pulley.
4. Disconnect the ignition control module, then remove the engine air inlet connector.
5. Remove the upper outer timing belt cover.
6. Disengage the crankshaft position sensor wiring harness at the connector, then route the crankshaft position sensor harness through the outer timing belt cover.
7. Raise and safely support the vehicle, then remove the right front wheel and tire assembly.
8. Remove the crankshaft vibration damper and pulley using Steering Wheel Puller T67L-3600-A, or equivalent.
9. Remove the center and lower outer timing belt cover.
10. Rotate the crankshaft by hand to position the metal vane of the crankshaft sprocket outside of the crankshaft position sensor air gap.
11. Remove the two CKP sensor retaining screws, then remove the crankshaft position sensor from the engine.

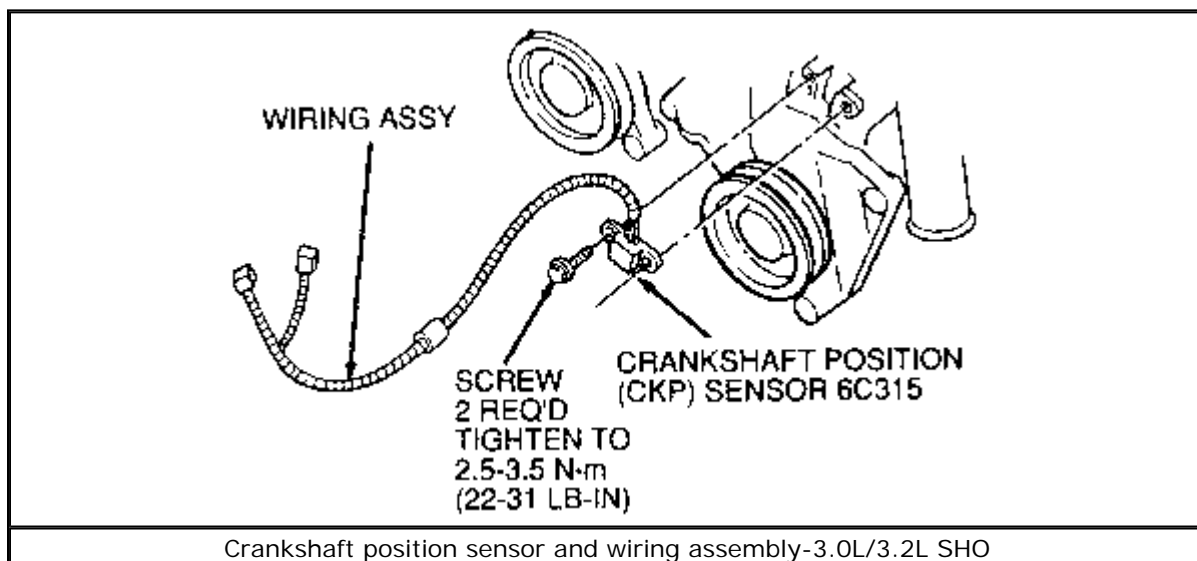

[Click to enlarge](#)

To install:

12. Route the crankshaft position sensor wiring harness through the outer timing belt cover. Position the CKP sensor on the mounting pad and install the retaining screws loosely. Do NOT tighten the screws at this time.
13. Set the clearance between the CKP sensor assembly and one vane on the crankshaft sprocket with a 0.03 in. (0.8mm) feeler gauge, then tighten the retaining screws to 22-31 inch lbs. (2.5-3.5 Nm).

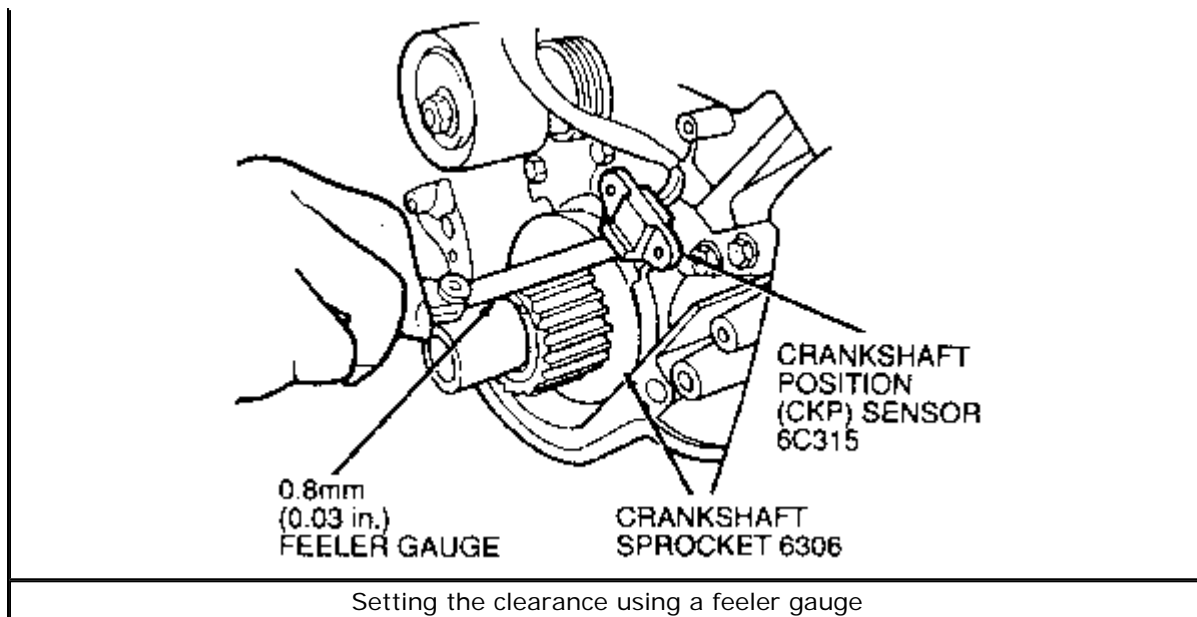

[Click to enlarge](#)

Do NOT overtighten the CKP retaining screws! Damage to the crankshaft position sensor will result.

14. Install the lower outer timing belt cover. Make sure you don't damage the CKP sensor wiring harness. Install the crankshaft vibration damper and pulley using the Crank Gear and Damper Replacer T83T-6316-B, or equivalent. Tighten the pulley bolt to 112-127 ft. lbs. (152-172 Nm).
15. Install the center outer timing belt cover.
16. Install the wheel and tire assembly. Tighten the lug nuts to 85-105 ft. lbs. (115-142 Nm), then lower the vehicle.
17. Route and connect the crankshaft position sensor wiring harness.
18. Install the upper outer timing belt cover.
19. Install the engine air inlet connector, then engage the ignition control module.
20. Install the A/C compressor and power steering pump drive belts.
21. Connect the negative battery cable.

Camshaft Position (CMP) Sensor

1. Disconnect the negative battery cable.
2. Remove the front engine support damper.
3. Remove the power steering pump drive belt.
4. Remove the power steering pump pulley.
5. Disengage the Camshaft Position (CMP) sensor wiring connector.
6. Remove the CMP sensor retaining bolts, then remove the camshaft position sensor.

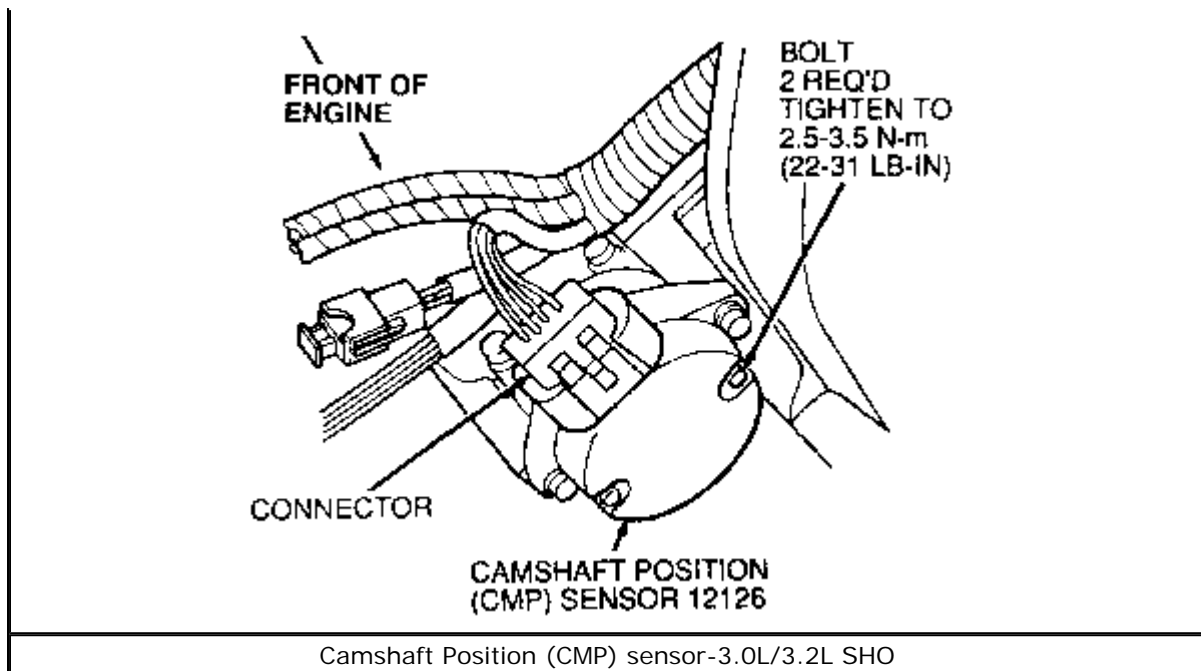

[Click to enlarge](#)

To install:

7. Install the camshaft position sensor and secure using the retaining bolts. Tighten the bolts to 22-31 inch lbs. (2.5-3.5 Nm).
8. Engage the camshaft position sensor wiring connector.
9. Install the power steering pump pulley, then install the power steering belt.
10. Install the front engine support damper.
11. Connect the negative battery cable.

Ignition Coil

1. Disconnect the negative battery cable.
2. Remove the ignition coil cover, then disengage the engine control sensor wiring connector from the ignition coil and, if equipped, the radio ignition interference capacitor.
3. Remove the ignition coil wires by squeezing the locking tabs together to release the ignition coil boot retainers.
4. Remove the ignition coil retaining screws, then remove the ignition coil and, if applicable, the radio interference capacitor.

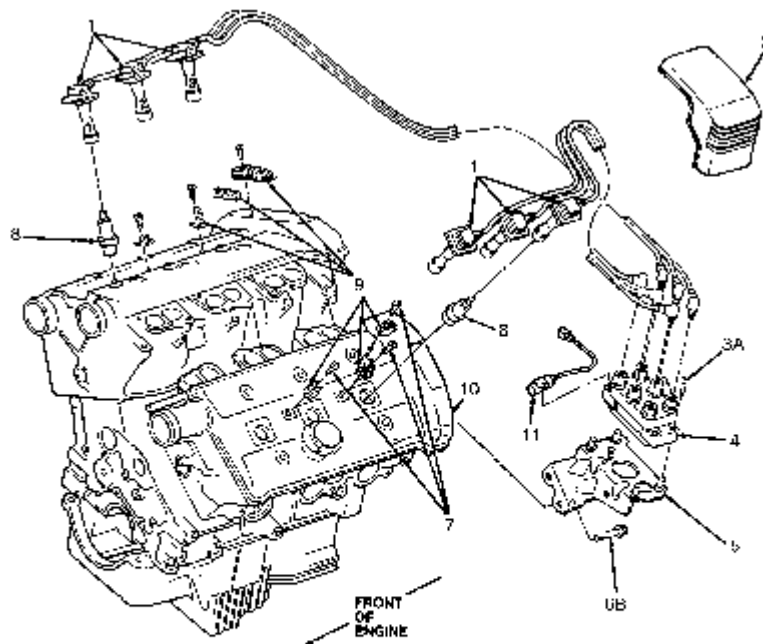

- | | |
|-----------------------------|--|
| 1 Ignition wire (6 req'd) | 8 Spark plug (6 req'd) |
| 2 Ignition coil cover | 9 Ignition wire separator |
| 3 Screw (4 req'd) | 10 Valve cover |
| 4 Ignition coil | 11 Radio ignition interference capacitor |
| 5 Ignition coil bracket | A Tighten to 4.5-7.0 Nm (40-62 lb.in.) |
| 6 Bolt (2 req'd) | B Tighten to 28-42 Nm (21-31 lb.ft.) |
| 7 Screw (8 req'd each side) | |

Ignition coil and related system components-3.0L/3.2L SHO

[Click to enlarge](#)

To install:

5. Install the ignition coil, radio ignition interference capacitor (if equipped) and the retaining screws. Tighten the screws to 40-62 inch lbs. (4.5-7.0 Nm).
6. Connect the ignition wires to the proper ignition coil terminals. Engage the engine control sensor wiring connector to the ignition coil and, if applicable, the radio ignition interference capacitor.
7. Install the ignition coil cover, then connect the negative battery cable.

Ignition Control Module

1. Disconnect the negative battery cable.
2. Disengage both engine control sensor wiring connectors at the Ignition Control Module (ICM), by pressing down on the locking tabs stamped "PUSH", then remove the wiring connector.
3. Unfasten the retaining bolts, then remove the ICM.

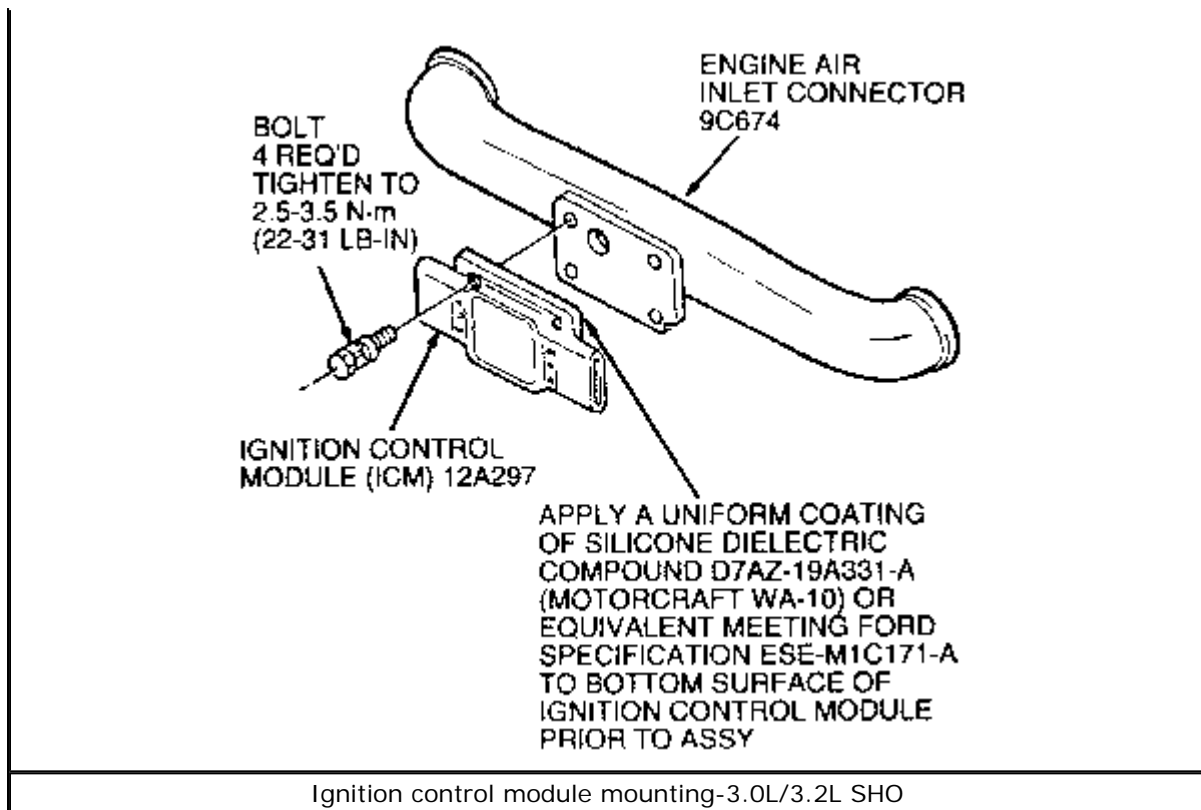

[Click to enlarge](#)

To install:

4. Apply an even coat of about $\frac{1}{32}$ in. (0.8mm) of Silicone Dielectric Compound D7AZ-19A331-A, or equivalent, to the mounting surface of the ignition control module.
5. Install the ICM and secure using the retaining bolts. Tighten the bolts to 22-31 inch lbs. (2.5-3.5 Nm).
6. Engage both engine control sensor wiring connectors to the ignition control module.
7. Connect the negative battery cable.

3.0L FLEXIBLE FUEL (FF) VEHICLES

Crankshaft Position Sensor

1. Disconnect the negative battery cable.
2. Raise and safely support the vehicle.
3. Disconnect the fuel charging wiring from the crankshaft position sensor.
4. Remove the crankshaft position sensor retaining bolts, then remove the crankshaft position sensor.

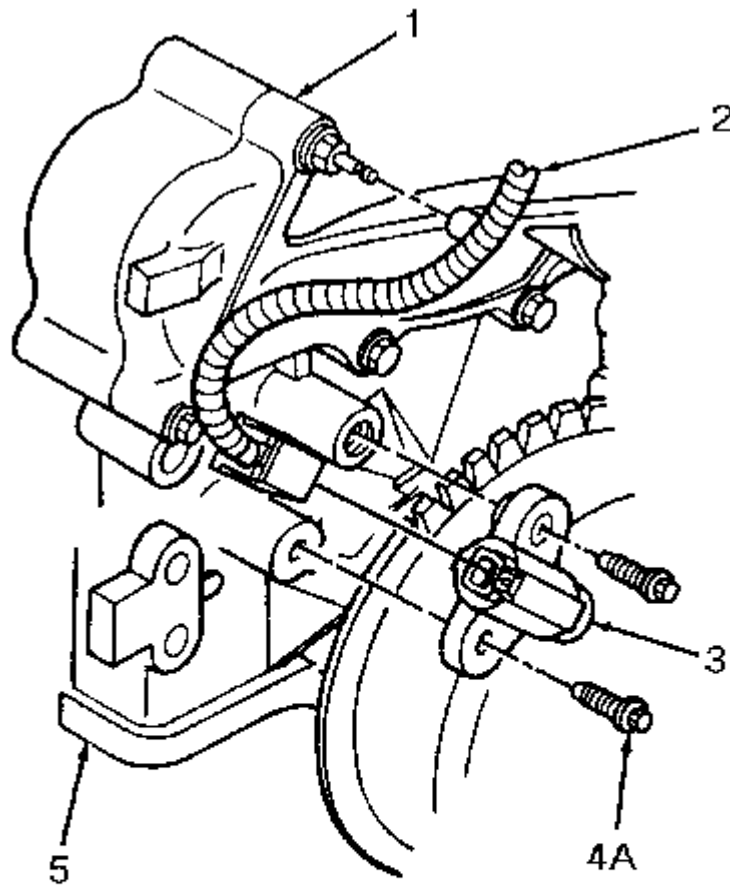

- 1 Water pump
- 2 Fuel charging wiring
- 3 Crankshaft position sensor
- 4 Bolt (2 req'd)
- 5 Engine front cover
- A Tighten to 5-7 Nm (44-61 lb.in.)

Crankshaft position sensor-3.0L Flexible Fuel (FF)

[Click to enlarge](#)

To install:

5. Position the crankshaft position sensor and secure using the retaining bolts. Tighten the retaining bolts to 44-61 inch lbs. (5-7 Nm).

Do NOT overtighten the retaining bolts or damage to the crankshaft position sensor may result!

6. Properly route the fuel charging wiring, then connect it to the crankshaft position sensor.
7. Lower the vehicle, then connect the negative battery cable.

Ignition Coil

1. **Disconnect the negative battery cable.**
2. **Disengage the fuel charging wiring connectors from the ignition coil and the radio ignition interference capacitor.**
3. **Disconnect the ignition wires by squeezing the locking tabs together and twisting while pulling upward.**
4. **Remove the four ignition coil retaining screws, then remove the ignition coil and radio interference capacitor from the ignition coil bracket. Save the capacitor for installation with the ignition coil.**

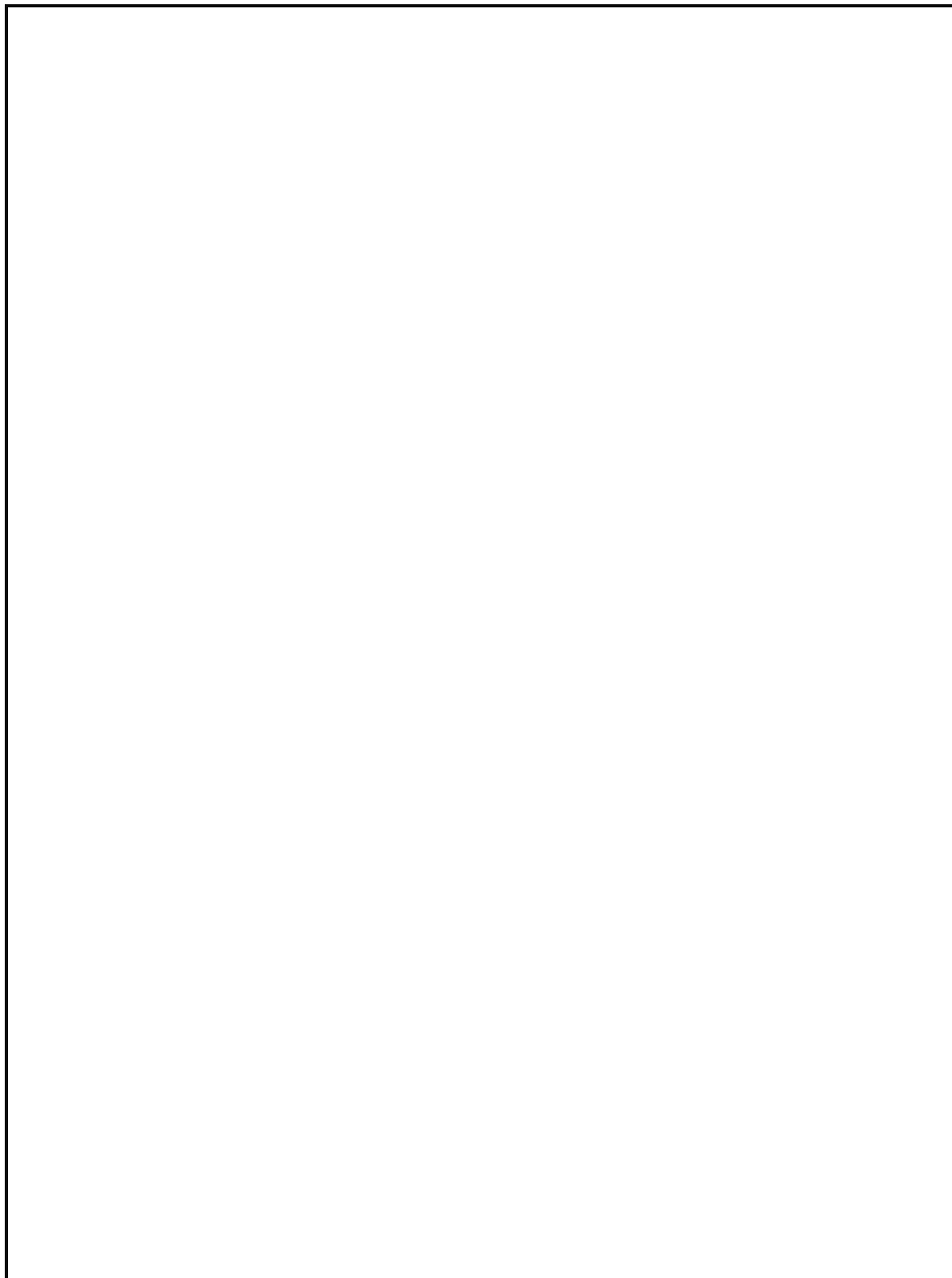

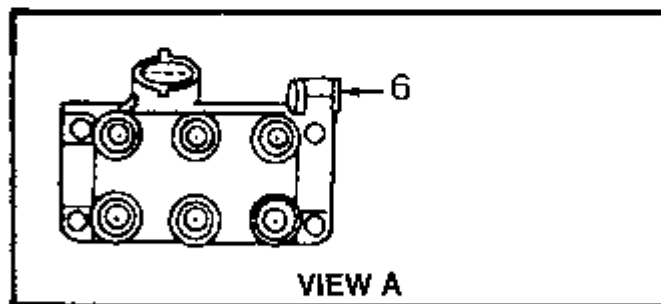
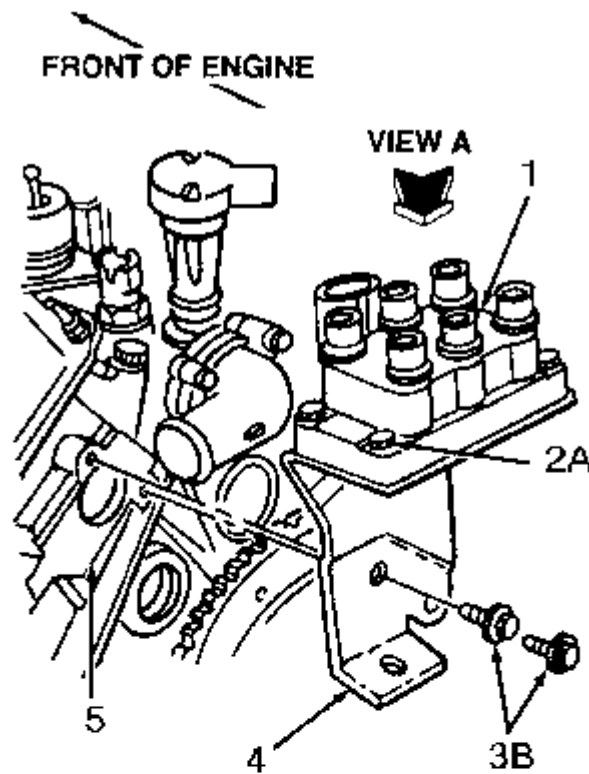

- 1 Ignition coil
- 2 Screw (4 req'd)
- 3 Bolt (2 req'd)
- 4 Ignition coil mounting bracket
- 5 Cylinder head (LH)
- 6 Radio ignition interference capacitor
- A Tighten to 4.5-7.0 Nm (44-61 lb.in.)
- B Tighten to 40-55 Nm (30-41 lb.ft.)

Ignition coil-3.0L FF vehicles

[Click to enlarge](#)

To install:

5. Position the ignition coil and radio ignition interference capacitor to the ignition coil bracket and secure with the retaining screws. Tighten the retaining screws to 44-61 inch lbs. (5-7 Nm).

6. Apply Silicone Dielectric Compound D7AZ-19A331-A, or equivalent, to all ignition wire boots.
7. Install each ignition wire connector to the proper terminal on the ignition coil, making sure all of the boots are fully seated.
8. Connect the fuel charging wiring to the ignition coil and radio ignition interference capacitor, then connect the negative battery cable.

Ignition Control Module

1. Disconnect the negative battery cable.
2. Disengage the engine control sensor wiring connector from the ignition control module by carefully lifting upwards on the locking tabs while grasping the connector body and pulling away from the ignition control module.
3. Remove the two ignition control module retaining screws, then remove the ignition control module.

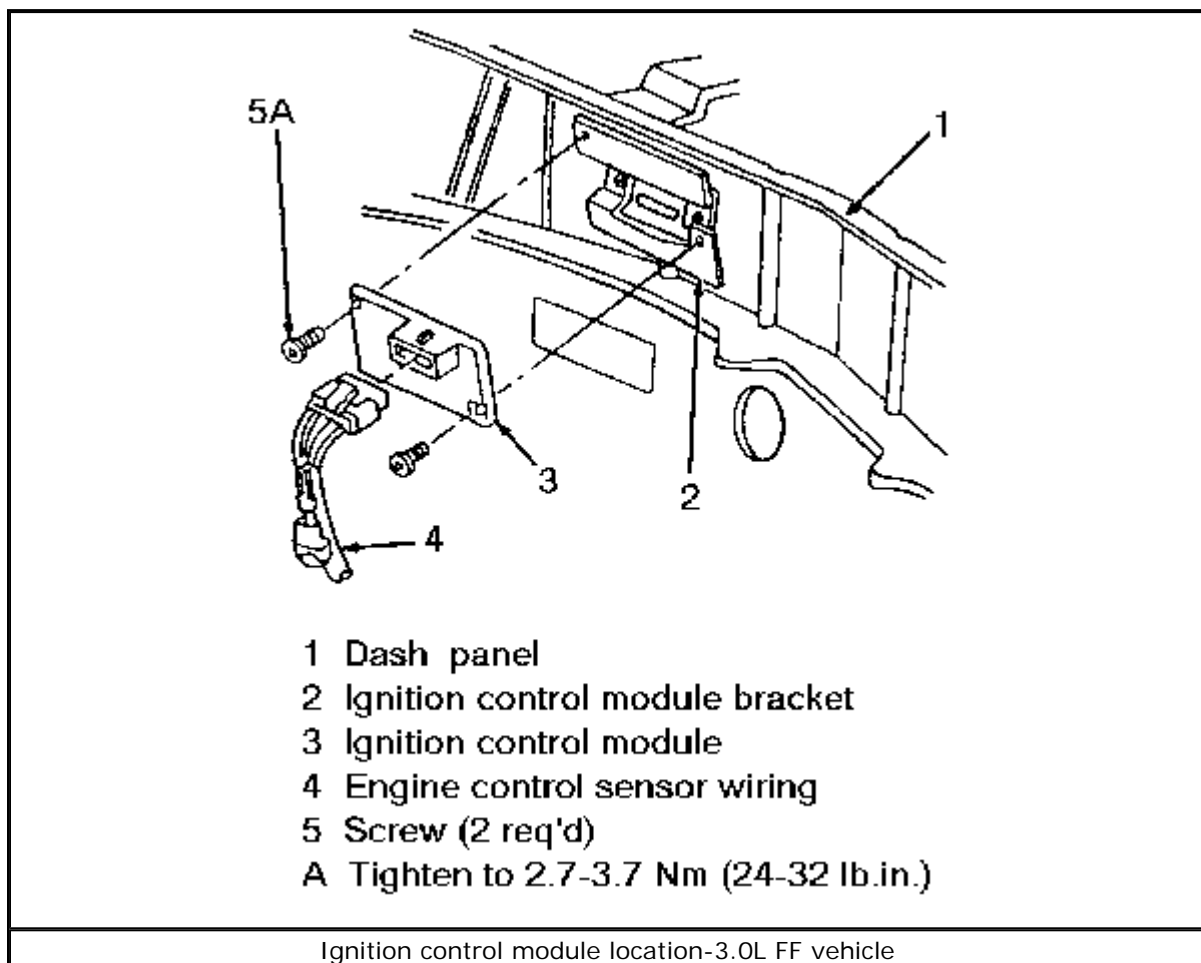

[Click to enlarge](#)

4. Position the ignition control module to the ignition control bracket and secure using the retaining screws. Tighten the screws to 24-32 inch lbs. (2.7-3.6 Nm).
5. Engage the ignition control module connector by pushing until the connector fingers are positioned over the locking wedge feature on the ICM.

Locking the connector is important to ensure sealing of the connector and ignition control module interface.

6. Connect the negative battery cable.

Chilton® Automotive Information Systems. © 2004 Thomson Delmar Learning.

IGNITION TIMING

Introduction

Ignition timing is the measurement, in degrees of crankshaft rotation, of the point at which the spark plugs fire in each of the cylinders. It is measured in degrees before or after Top Dead Center (TDC) of the compression stroke.

Because it takes a fraction of a second for the spark plug to ignite the mixture in the cylinder, the spark plug must fire a little before the piston reaches TDC. Otherwise, the mixture will not be completely ignited as the piston passes TDC and the full power of the explosion will not be used by the engine.

The timing measurement is given in degrees of crankshaft rotation BEFORE the piston reaches TDC (BTDC). If the setting for the ignition timing is 10° BTDC, the spark plug must fire 10° before each piston reaches TDC. This only holds true, however, when the engine is at idle speed.

As the engine speed increases, the pistons go faster. The spark plugs have to ignite the fuel even sooner if it is to be completely ignited when the piston reaches TDC. To do this, distributors have various means of advancing the spark timing as the engine speed increases. On some earlier model vehicles, this is accomplished by centrifugal weights within the distributor along with a vacuum diaphragm mounted on the side of the distributor. Models covered by this manual use signals from various sensors, making all timing changes electronically, and no vacuum or mechanical advance is used. The 3.0L and 3.2L SHO engines and the 3.0L Flexible Fuel engines use a distributorless electronic ignition system. Operation of this system allows for full electronic control of the timing.

If the ignition is set too far advanced (BTDC), the ignition and expansion of the fuel in the cylinder will occur too soon and tend to force the piston down while it is still traveling up. This causes engine ping. If the ignition spark is set too far retarded, After TDC (ATDC), the piston will have already passed TDC and started on its way down when the fuel is ignited. This will cause the piston to be forced down for only a portion of its travel, and will result in poor engine performance as well as a lack of power.

The timing marks on the 2.5L engine are visible through a hole in the top of the transaxle case. The 3.0L and 3.8L engines have the timing marks on the crankshaft pulley and a timing marker near the pulley. A stroboscopic (dynamic) timing light is used, which is hooked into the circuit of the No. 1 cylinder spark plug. Every time the spark plug fires, the timing light flashes. By aiming the timing light at the timing marks while the engine is running, the exact position of the piston within the cylinder can be easily read since the stroboscopic flash makes the mark on the pulley appear to be standing still. Proper timing is indicated when the notch is aligned with the correct number on the scale.

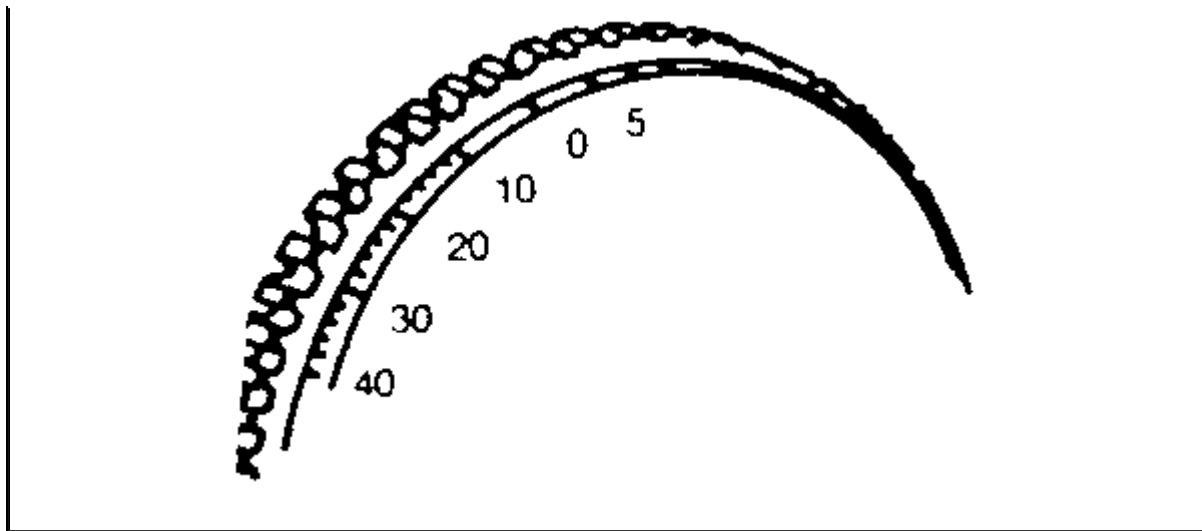

Timing mark on flywheel-2.5L engine with manual transaxle

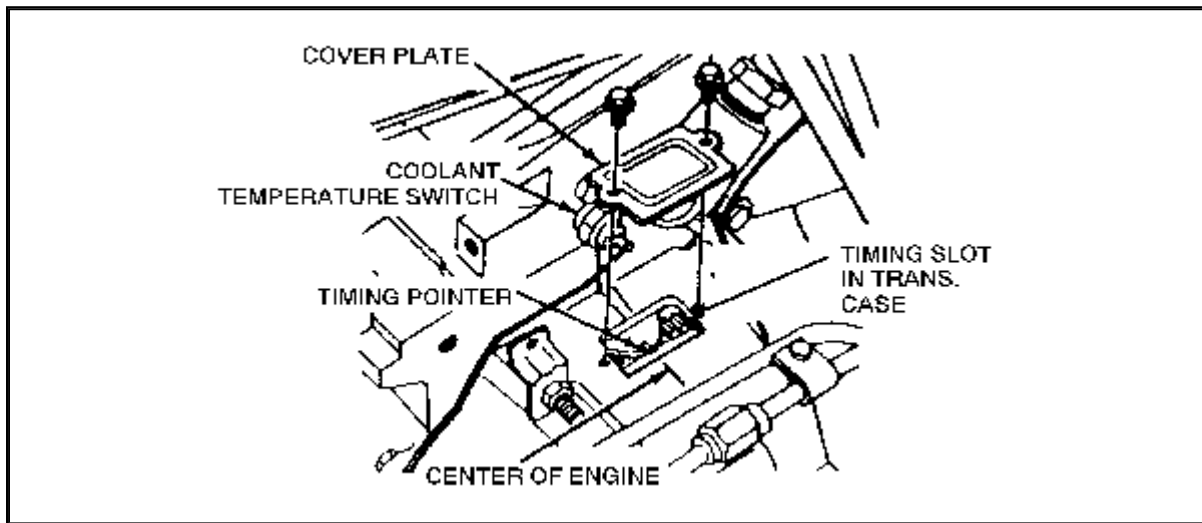

Timing pointer location-2.5L engine with manual transaxle

[Click to enlarge](#)

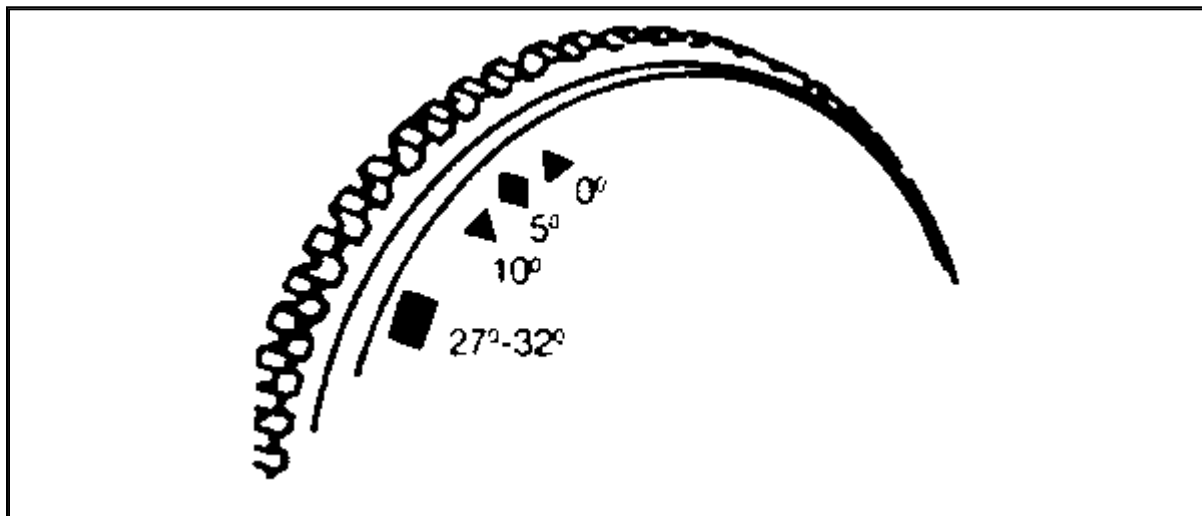

Timing mark on flywheel-2.5L engine with automatic transaxle

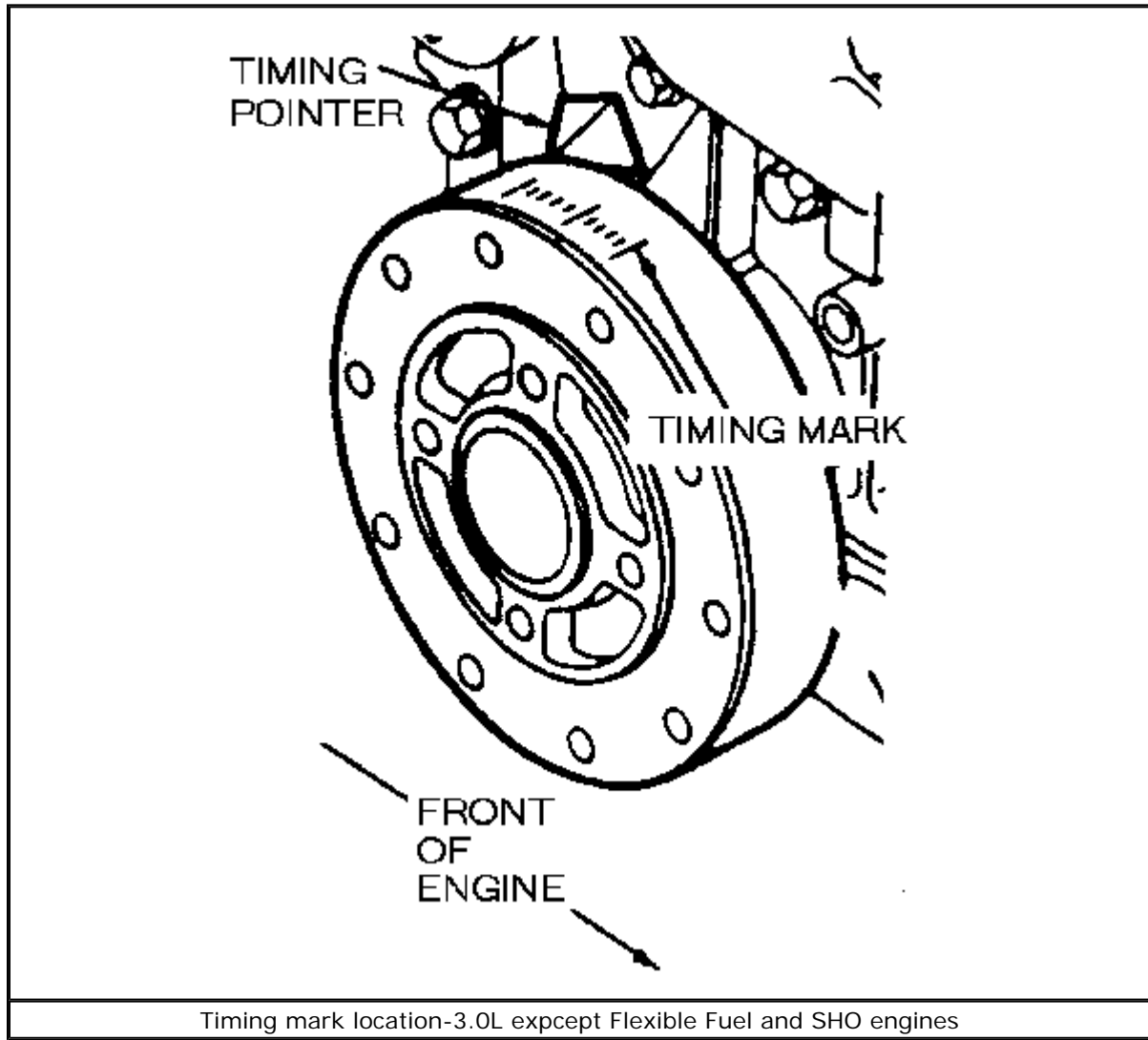
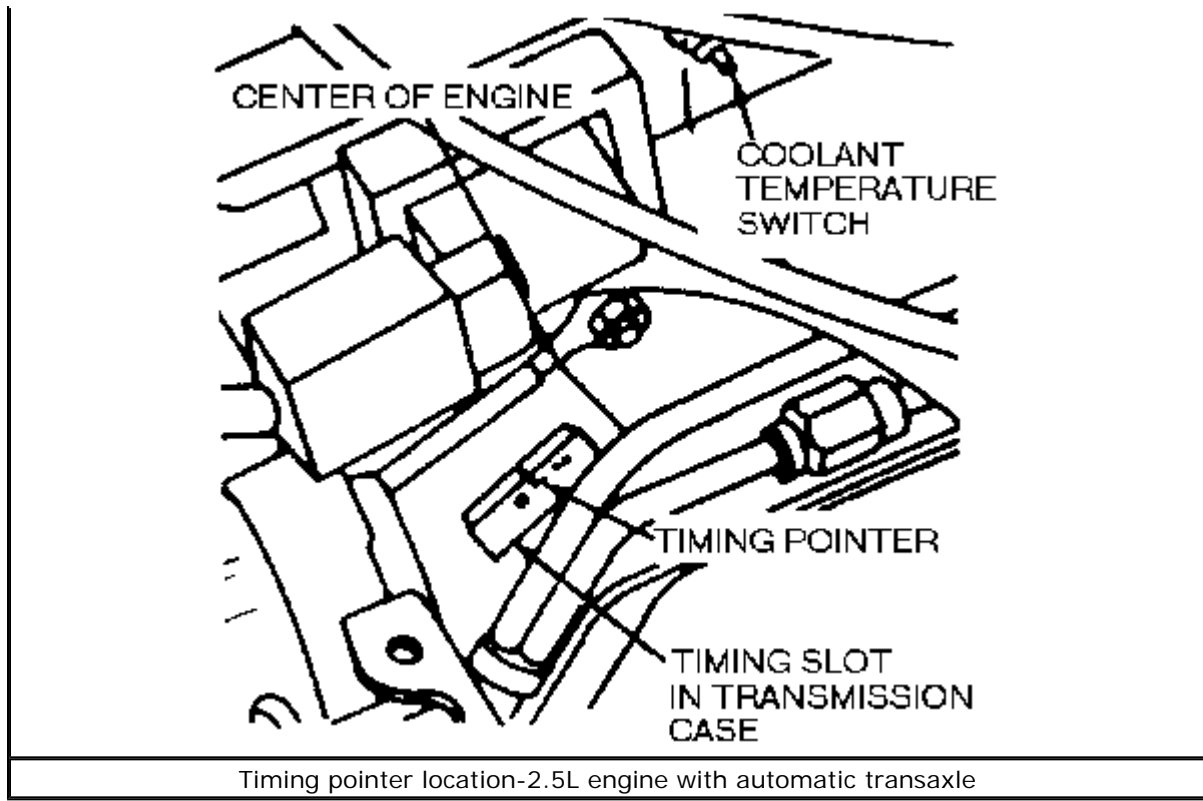

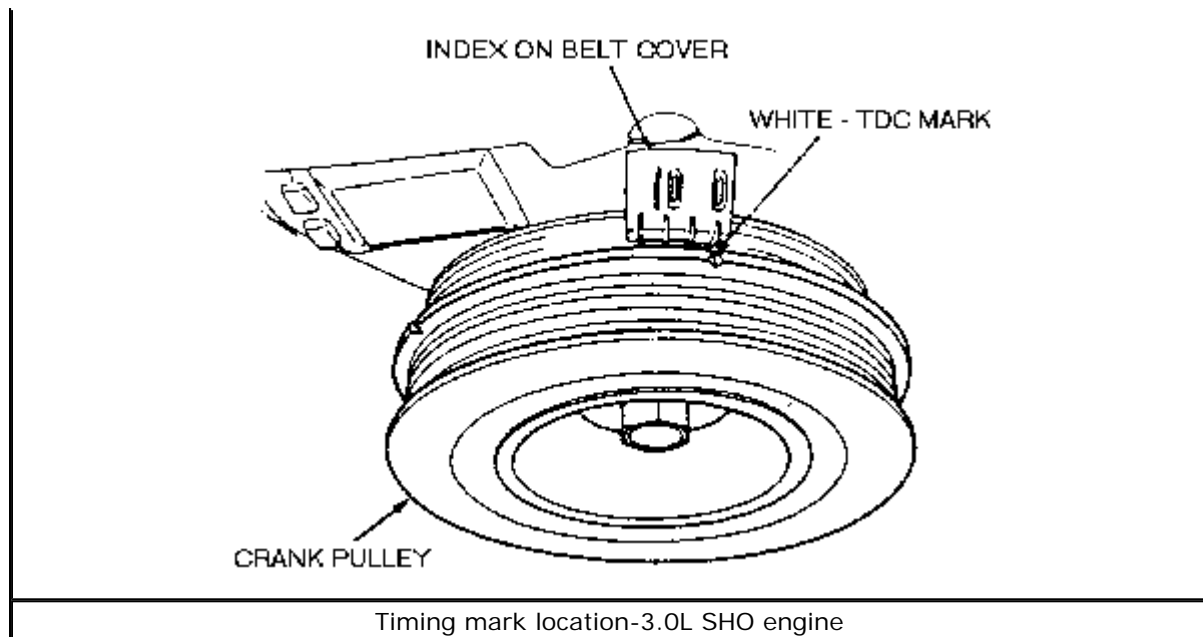

[Click to enlarge](#)

There are three basic types of timing lights available. The first is a simple neon bulb with two wire connections (one for the spark plug and one for the plug wire, to connect the light in series). This type of light is quite dim, and must be held closely to the marks to be seen, but it is quite inexpensive. The second type of light is powered by the car's battery. Two alligator clips connect to the battery terminals, while a third wire connects to the spark plug with an adapter. This type of light is more expensive, but the xenon bulb provides a nice bright flash which can even be seen in sunlight. The third type replaces the battery source with 110 volt house current, but still attaches to the No. 1 spark plug wire in order to determine when the plug is fired. Some timing lights have other functions built into them, such as dwell meters, tachometers, or remote starting switches. These are convenient, in that they reduce the tangle of wires under the hood, but may duplicate the functions of tools you already have.

Never pierce a spark plug wire in order to attach a timing light or perform tests. The pierced insulation will eventually lead to an electrical arc and related ignition troubles.

Since your car has electronic ignition, you should use a timing light with an inductive pickup. This pickup simply clamps onto the No. 1 spark plug wire, eliminating the adapter. It is not susceptible to cross-firing or false triggering, which may occur with a conventional light, due to the greater voltages produced by electronic ignition.

Timing

INSPECTION & ADJUSTMENT

Except 3.0L Flexible Fuel (FF), 3.0L and 3.2L SHO Engines

The timing marks on the 2.5L engine are located on the flywheel and are visible through a hole in the transaxle case for manual transaxles. To view the timing marks, a cover plate on top of the transaxle must be removed. For 2.5L engines equipped with automatic transaxles, the timing marks are visible through a hole

in the transaxle case.

The 3.0L and 3.8L engines have the timing marks on the crankshaft pulley and a timing pointer near the pulley. To check and adjust the ignition timing:

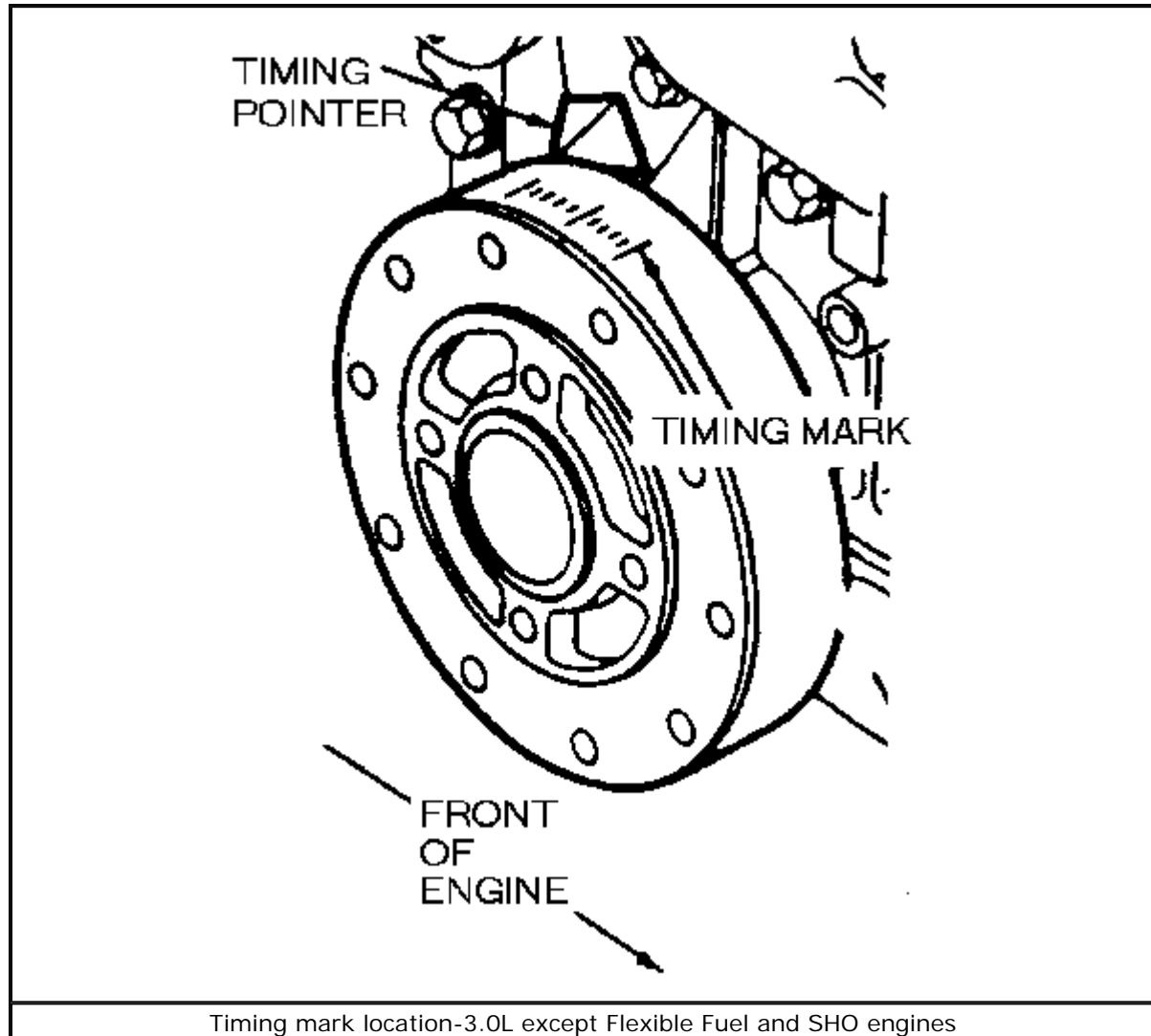

1. Place the transaxle in the P (AT) or N (MT) position. The air conditioner and heater must be in the OFF position.
2. Open the hood, locate the timing marks and clean them with a stiff brush or solvent. On vehicles equipped with a manual transaxle, it will be necessary to remove the transaxle cover plate which allows access to the timing marks.
3. Using a white chalk or paint, highlight the specified timing mark and pointer.
4. Near the distributor, detach the inline Spark Output (SPOUT) connector or remove the shorting bar from the double wire SPOUT connector. The spout connector is the center wire between the Electronic Control Assembly (ECA) connector and the Thick Film Integrated (TFI) or Ignition Control (ICM) module.
5. Connect an inductive-type timing light, Rotunda tool No. 059-00006 or equivalent, to the No. 1 spark plug wire. DO NOT puncture the ignition wire with any type of probing device.

The high ignition coil voltage generated in the EEC-IV ignition system may falsely trigger the timing lights with capacitive or direct connect pick-ups. It is necessary that an inductive type timing light be used in

this procedure.

6. Connect a suitable tachometer, Rotunda tool No. 099-00003 or equivalent, to the engine. The ignition coil connector allows a test lead with an alligator clip to be connected to the Distributor Electronic Control (DEC) terminal without removing the connector.

The ignition coil electrical connector allows a test lead with an alligator clip to be connected to its dark green/yellow dotted wire terminal without removing the connector. Be careful not to ground the alligator clip, for permanent damage to the ignition coil will result.

7. Start the engine, using the ignition key, and allow it to run until it reaches normal operating temperature.

Only use the ignition key to start the vehicle. Do NOT use a remote starter, as disconnecting the start wire at the starter relay will cause the TFI or ICM to revert back to the start mode timing, after the vehicle is started. Reconnecting the start wire after the vehicle is running will not correct the timing.

8. Check the engine idle rpm; if it is not within specifications, adjust as necessary. Idle speed is not adjustable on 1991-95 vehicles. After the rpm has been adjusted or checked, aim the timing light at the timing marks. If they are not aligned, loosen the distributor clamp bolts slightly and rotate the distributor body until the marks are aligned under the timing light illumination.
9. Tighten the distributor clamp bolts and recheck the ignition timing. Readjust the idle speed, if necessary or possible.
10. Turn the engine OFF, remove all test equipment, reconnect the inline SPOUT connector to the distributor and, if necessary, reinstall the cover plate on manual transaxle vehicles.

3.0L Flexible Fuel (FF), 3.0L and 3.2L SHO Engines

The base ignition timing is set at 10° Before Top Dead Center (BTDC) and is not adjustable.

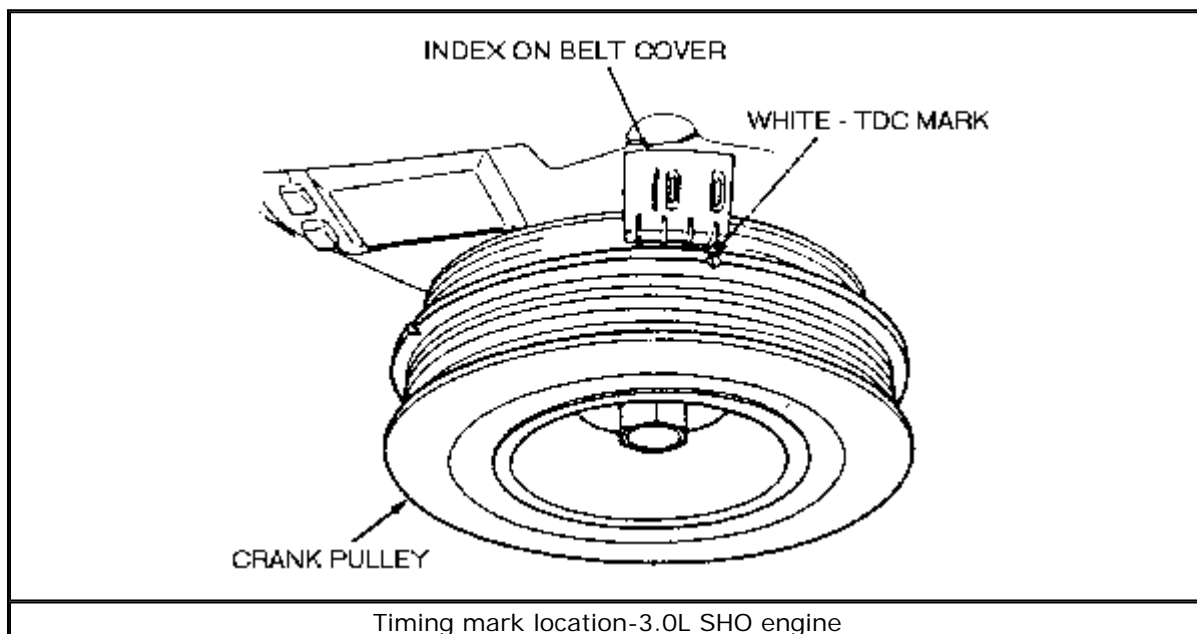

[Click to enlarge](#)

TACHOMETER HOOKUP

On distributor-equipped models with an "E" type ignition coil, the tachometer connection is made at the back of the wire harness connector. A cut-out is provided and the tachometer lead wire alligator clip can be connected to the dark green/yellow dotted wire of the electrical harness plug.

Chilton® Automotive Information Systems. © 2004 Thomson Delmar Learning.

VALVE LASH

Introduction

Valve lash adjustment determines how far the valves enter the cylinder and how long they stay open and/or closed.

While all valve adjustments must be made as accurately as possible, it is better to have the valve adjustment slightly loose than slightly tight, as a burned valve may result from overly tight adjustments.

Checking

The valve stem-to-rocker arm clearance for all engines except the 3.0L and the 3.2L SHO should be within specification with the valve lifter completely collapsed. To determine the rocker arm-to-valve lifter clearance, make the following checks:

2.5L ENGINE

1. Set the No. 1 piston on TDC of the compression stroke. The timing marks on the camshaft and crankshaft gears will be together. Check the clearance in the No. 1 intake, No. 1 exhaust, No. 2 intake and No. 3 exhaust valves.
2. Rotate the crankshaft 1 complete turn (360°), or 180° for the camshaft gear. Check the clearance on the No. 2 exhaust, No. 3 intake, No. 4 intake and No. 4 exhaust valves.
3. The clearance between the rocker arm and the valve stem tip should be 0.071-0.170 in. (1.80-4.34mm) with the lifter on the base circle of the cam.

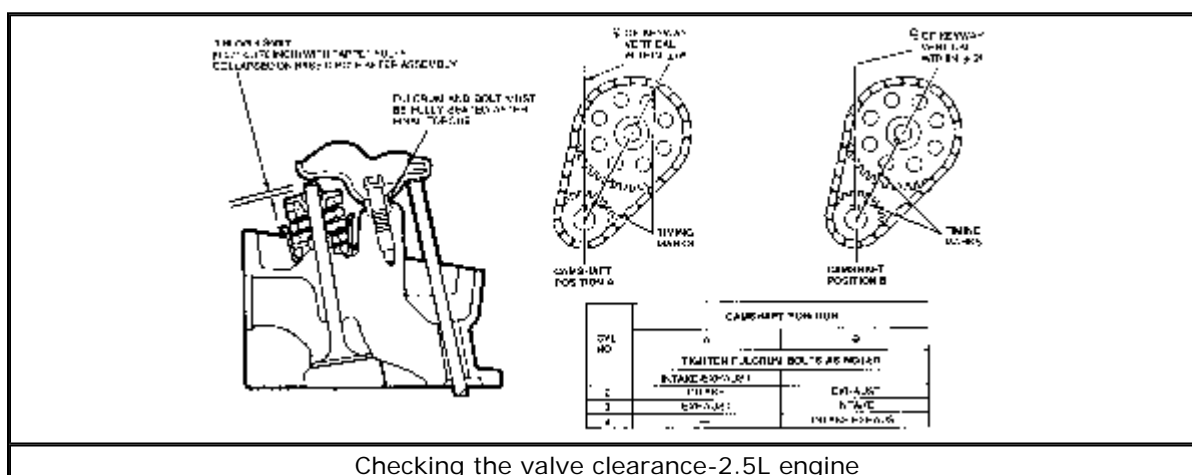

[Click to enlarge](#)

3.0L AND 3.8L ENGINE-EXCEPT SHO

4. Rotate the engine until the No. 1 cylinder is at TDC of its compression stroke and check the clearance between the following valves:

1. No. 1 intake and No. 1 exhaust valves
2. No. 3 intake and No. 2 exhaust valves
3. No. 6 intake and No. 4 exhaust valves

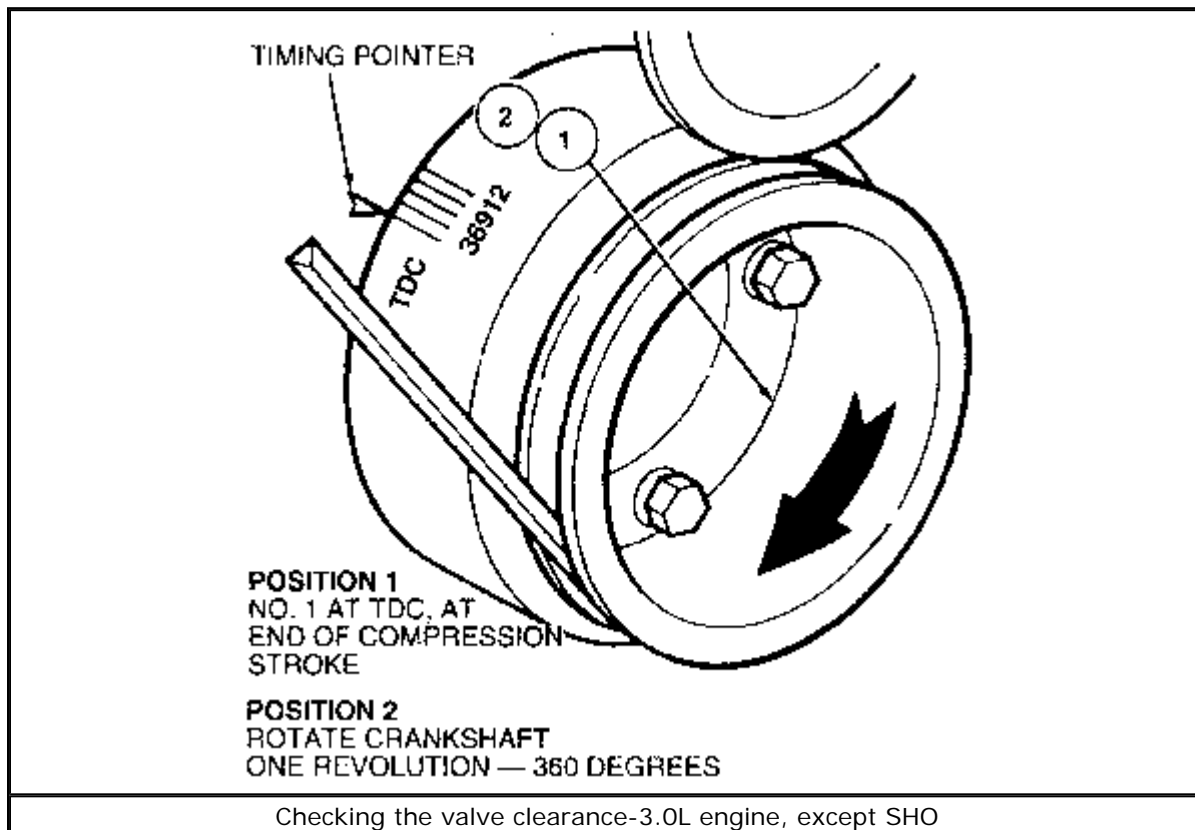

[Click to enlarge](#)

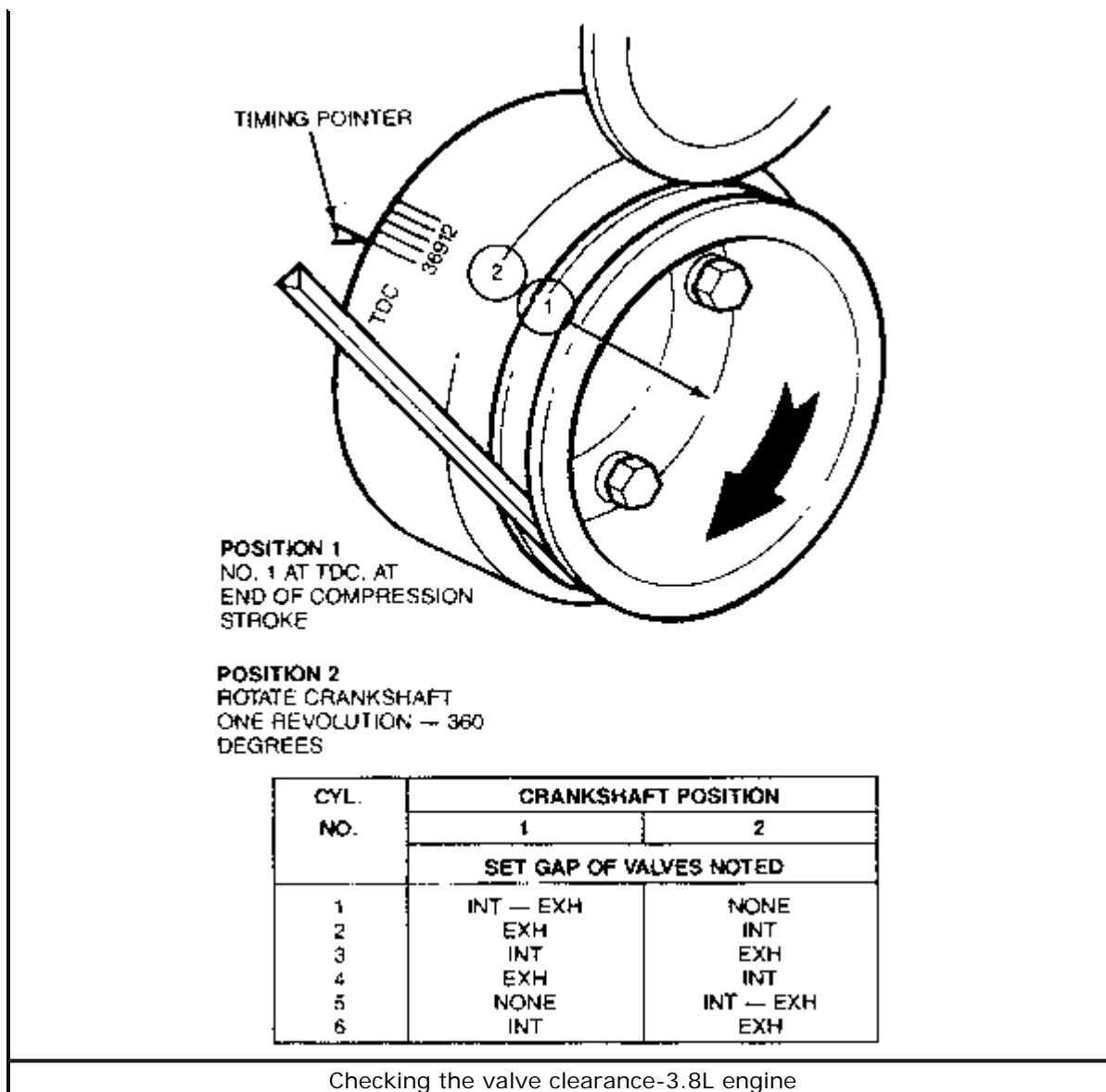

[Click to enlarge](#)

5. Rotate the crankshaft 360° and check the clearance between the rocker arm and the following valves:
 1. No. 2 intake and No. 3 exhaust valves
 2. No. 4 intake and No. 5 exhaust valves
 3. No. 5 intake and No. 6 exhaust valves
6. The clearance should be 0.085-0.185 in. (2.15-4.69mm) for the 3.0L engine and 0.089-0.189 in. (2.25-4.79mm) for the 3.8L engine.

3.0L AND 3.2L SHO ENGINES

1. Disconnect the negative battery cable.
2. Remove the valve cover. For the 3.2L SHO engine, first remove the EGR valve-to-exhaust manifold tube to gain access to the right-hand valve cover. For details regarding these procedures, please refer to *Section 3* of this manual.
3. Remove the intake manifold assembly. For details regarding this procedure, please refer to *Section 3* of this manual.

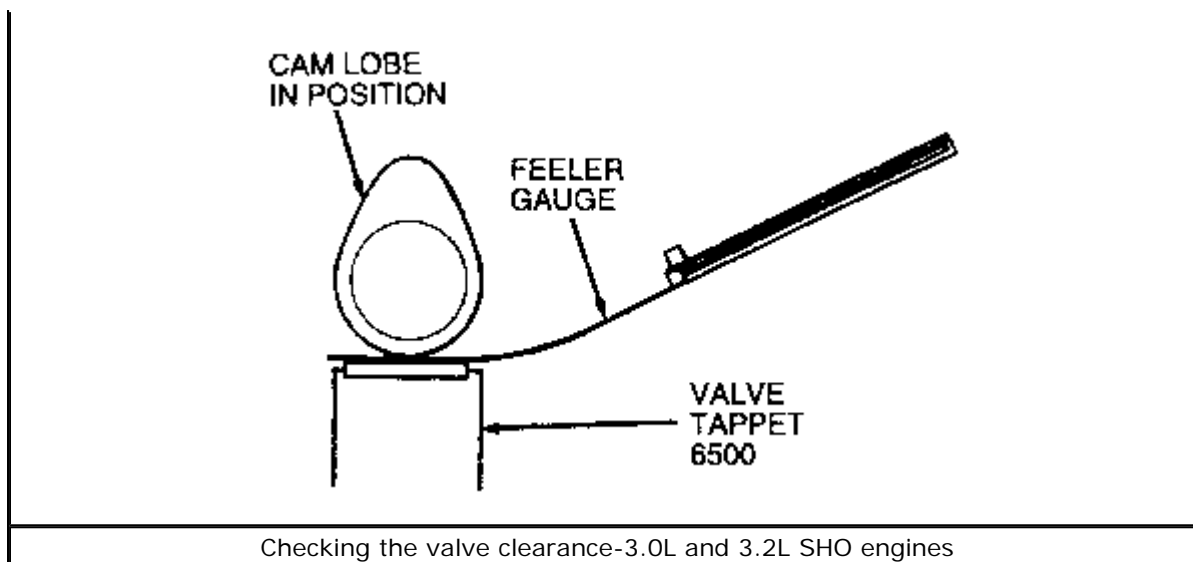

4. Insert a feeler gauge under the cam lobe at a 90° angle to the camshaft. Clearance for the intake valves should be 0.006-0.010 in. (0.15-0.25mm). Clearance for the exhaust valves should be 0.010-0.014 in. (0.25-0.35mm).

The cam lobes must be directed 90° or more away from the valve lifters/tappets.

Adjustment

For all engines covered by this manual, except the 3.0L and 3.2L SHO, the intake and exhaust valves are driven by the camshaft working through hydraulic lash adjusters. The lash adjusters eliminate the need for periodic valve lash adjustments.

3.0L AND 3.2L SHO ENGINES

1. Disconnect the negative battery cable.
2. Remove the valve covers. For the 3.2L SHO engine, remove the EGR valve-to-exhaust manifold tube to gain access to the right-hand valve cover. For details regarding these procedures, please refer to *Section 3* of this manual.
3. Remove the intake manifold assembly. For details regarding this procedure, please refer to *Section 3* of this manual.
4. Install Lifter/Tappet Compressor T89P-6500-A or equivalent under the camshaft, next to the lobe, and rotate it downward to depress the valve lifter/tappet.

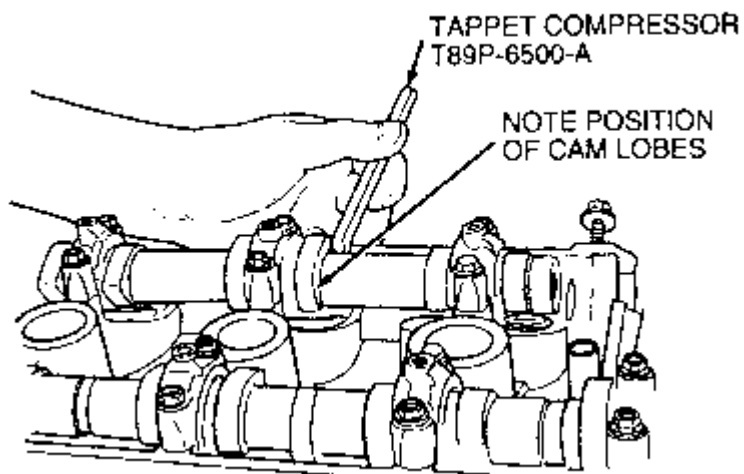

Install the compressor tool under the cam, next to the lobe, and rotate it down to depress the valve lifter/tappet

[Click to enlarge](#)

5. Install the valve lifter/tappet holding tool T89P-6500-B or equivalent, and remove the compressor tool.

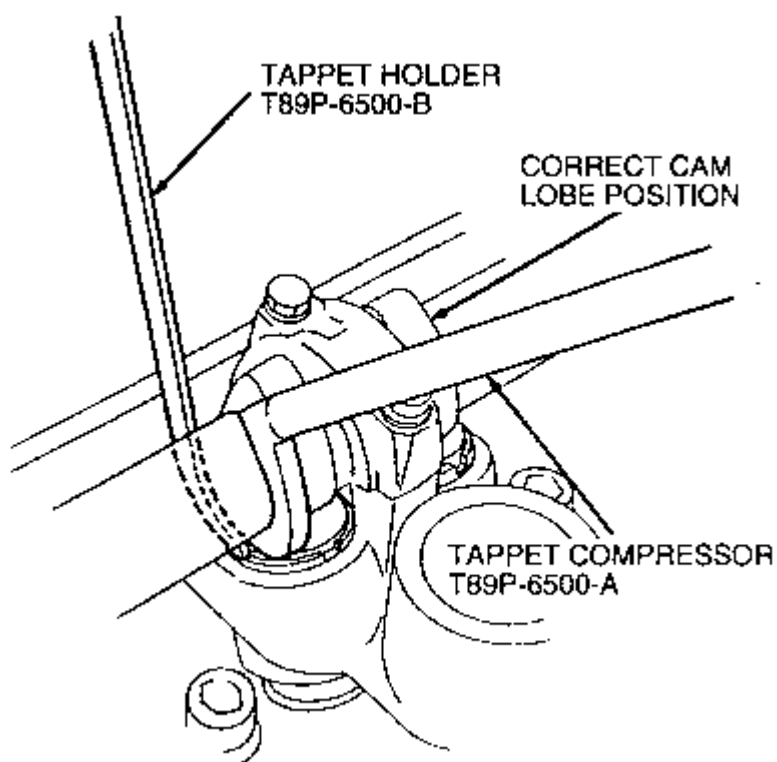

Install the holding tool, then remove the compressor tool

[Click to enlarge](#)

6. Using O-ring tool T71P-19703-C or equivalent, lift the valve adjusting spacer and remove the spacer with a magnet.

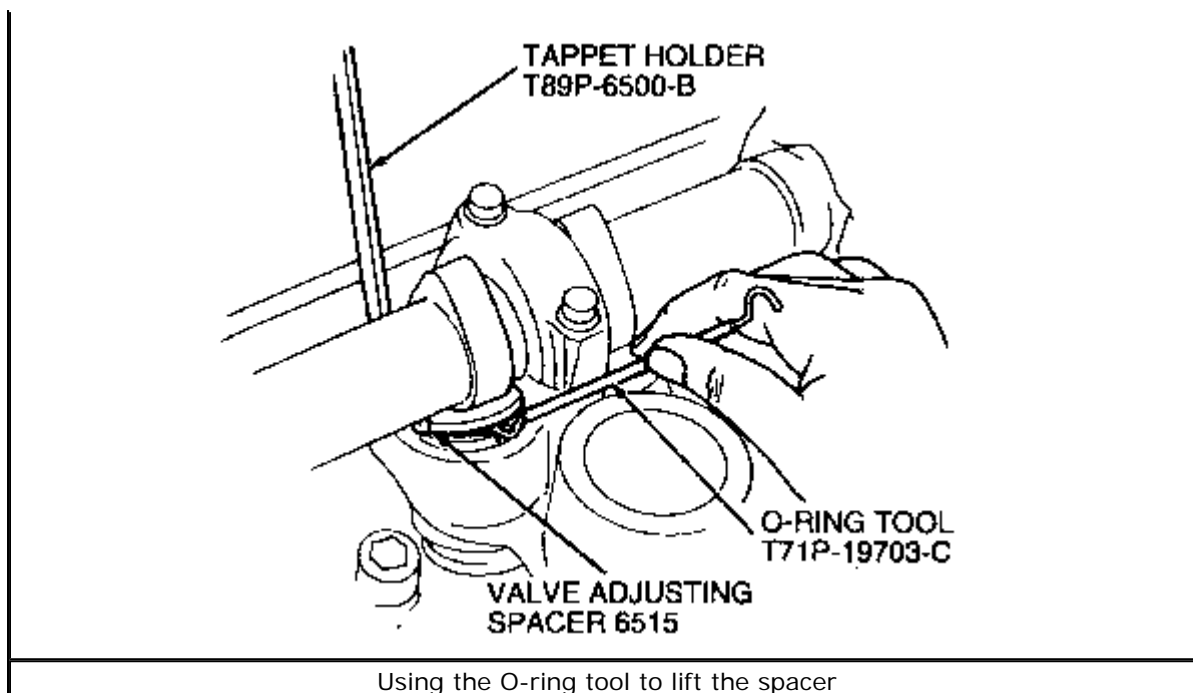

[Click to enlarge](#)

7. Determine the size of the spacer by the numbers on the bottom face of the spacer, or by measuring it with a micrometer.
8. Install the replacement valve adjusting spacer that will permit the specified clearance. Be sure to install the spacer with the numbers down and make sure the spacer is properly seated.
9. Release the lifter/tappet holder by installing the compressor tool.
10. Repeat the procedure for each valve by rotating the crankshaft as necessary.
11. After all of the valve clearances are checked and/or adjusted, inspect all of the spacers to ensure that they are fully seated in their valve lifters/tappets.
12. Inspect the valve cover gaskets and replace, if necessary. For details regarding this procedure, please refer to *Section 3* of this manual.
13. Install the intake manifold and the valve covers, as described in *Section 3* of this manual
14. Connect the negative battery cable.

IDLE SPEED AND MIXTURE ADJUSTMENTS

Idle Speed Adjustment

The idle speed on 1991-95 vehicles is preset at the factory, and is not adjustable.

2.5L ENGINE

1986-90 Vehicles

The curb idle and fast idle speeds are controlled by the EEC-IV computer and the Idle Speed Control (ISC) device. If the control system is operating correctly, the speeds are fixed and should not be changed.

1. Apply the parking brake and block the drive wheels, then place the vehicle in P (AT) or N (MT).
2. Start the engine and let it run until it reaches normal operating temperature, then turn the engine OFF.
3. Disconnect the negative battery cable for at least 5 minutes, then reconnect it.
4. Start the engine and let it run at idle speed for 2 minutes. The idle rpm should now return to the specified idle speed. The idle specifications can be found on the calibration sticker located under the hood.
5. Lightly step on and off the accelerator. The engine rpm should return to the specified idle speed. If the engine does not idle properly, proceed to Step 6.
6. Shut the engine OFF, then remove the air cleaner. Locate the self-test connector and self-test input connector in the engine compartment.
7. Connect a jumper wire between the self-test input connector and the signal return pin, the top right terminal on the self-test connector.

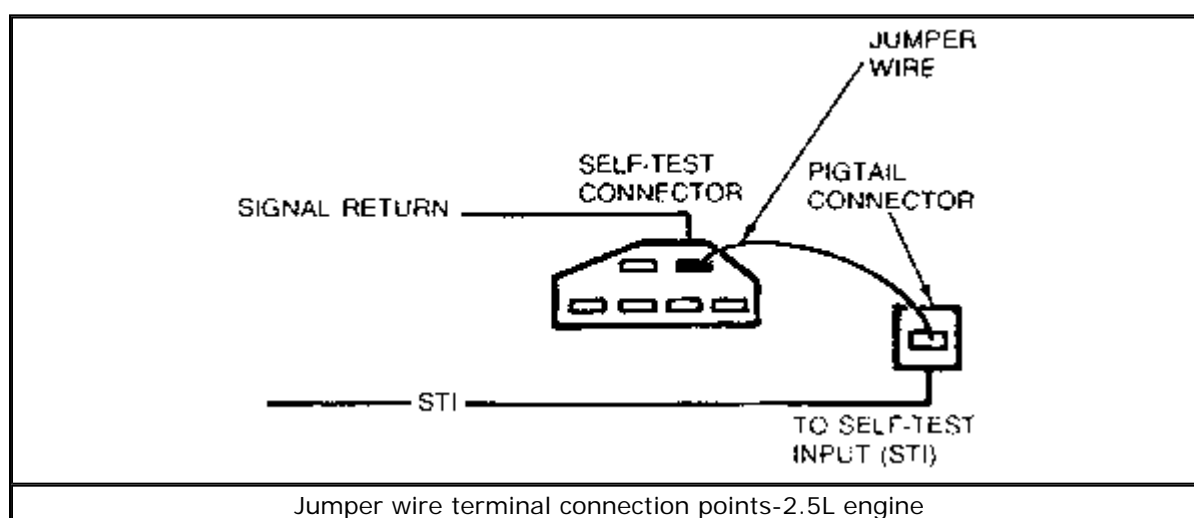

[Click to enlarge](#)

8. Place the ignition key in the RUN position, but do not start the engine. The Idle Speed Control (ISC) plunger will retract, so wait approximately 10-15 seconds until the plunger is fully retracted.
9. Turn the ignition key to the OFF position. Remove the jumper wire, then unplug the ISC motor from the wiring harness.
10. Start the engine and check the idle speed. On vehicles equipped with automatic transaxles, the idle should be 50 rpm less than that specified on the calibrations sticker. On vehicles equipped with manual transaxles, the idle should be 100 rpm less than that on the calibration sticker. If not, proceed to Step 11.
11. Remove the throttle body from the vehicle. For details regarding this procedure, please refer to *Section 5* of this manual.
12. Using a small punch, or equivalent, punch through and remove the aluminum plug which covers the throttle stop adjusting screw.

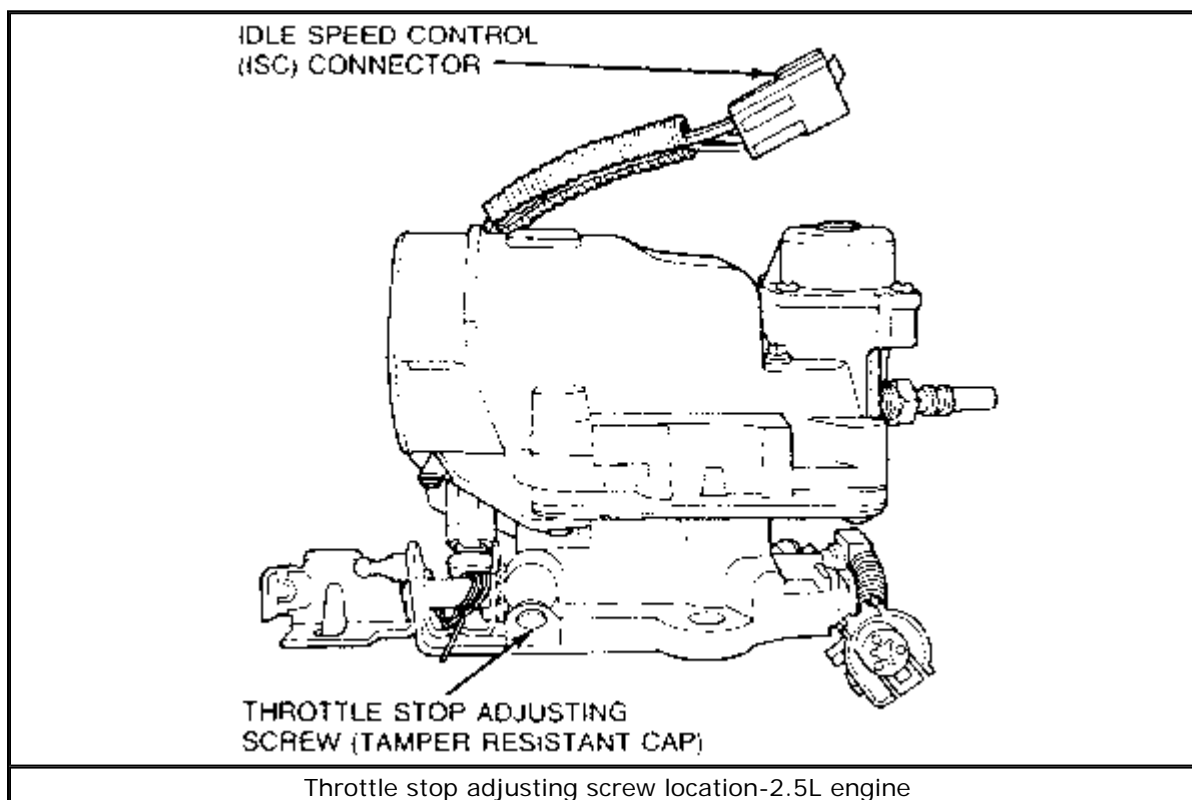

[Click to enlarge](#)

13. Remove and replace the throttle stop screw, then install the throttle body assembly onto the vehicle.
14. Start the engine and allow the idle to stabilize. Set the idle rpm to that specified in Step 10.
15. Turn the engine OFF. Reconnect the ISC motor wire harness, remove all test equipment, then reinstall the air cleaner assembly.

3.0L ENGINE-EXCEPT SHO

1986-90 Vehicles

The curb idle speed rpm is controlled by the EEC-IV computer (ECM) and the Idle Speed Control (ISC) air bypass valve assembly. The throttle stop screw is factory set and does not directly control the idle speed.

Adjustment of this setting should be performed only as part of a full EEC-IV diagnosis of irregular idle conditions or idle speeds. Failure to accurately set the throttle plate stop position as described in the following procedure could result in false idle speed control.

1. Apply the parking brake, turn the A/C control selector OFF and block the wheels.
2. Connect a tachometer and an inductive timing light to the engine. Start the engine and allow it to reach normal operating temperatures.
3. Unplug the Spark Output (SPOUT) line at the distributor, then check and/or adjust the ignition timing to the specification listed on the underhood emission calibration decal.
4. Shut the engine OFF and remove the PCV hose from the PCV valve. Install a 0.20 in. (5mm) diameter orifice, tool T86P-9600-A or equivalent.
5. Disengage the electrical connector from the idle speed control/air bypass valve solenoid.

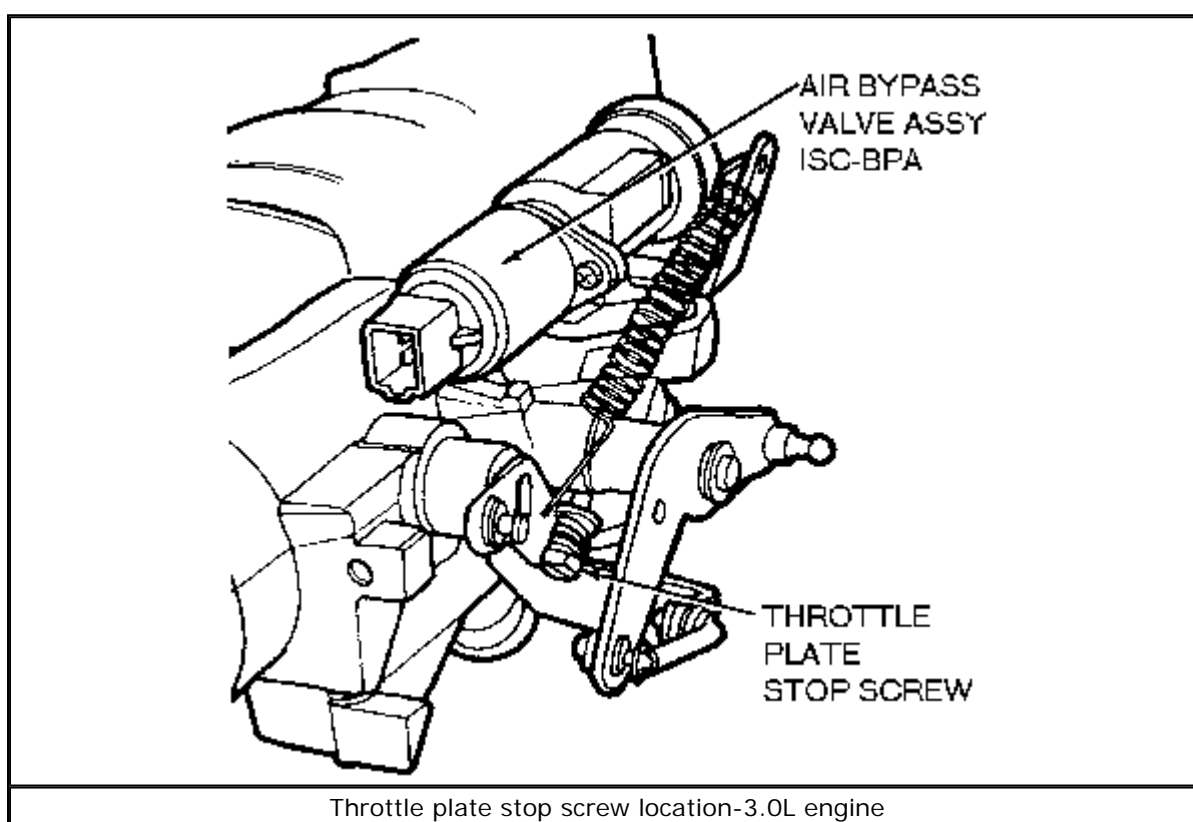

Throttle plate stop screw location-3.0L engine

[Click to enlarge](#)

6. Start the engine and run it at 2,000 rpm for 30 seconds.
7. If equipped with an automatic transaxle, place the selector in D. If equipped with a manual transaxle, place the selector in Neutral.
8. Check and/or adjust (if necessary) the idle speed to 740-780 rpm by turning the throttle plate stop screw.
9. After adjusting the idle speed, stop the engine, then disconnect the battery for at least 5 minutes.
10. Start the engine and confirm that the idle speed is now adjusted to specifications; if not, readjust as necessary.
11. Turn the engine OFF and remove all test equipment. Reconnect the PCV entry line,

the SPOUT line and the idle speed control/air bypass solenoid.

12. Make sure the throttle plate is not stuck in the bore and that the linkage is not preventing the throttle from closing.

3.0L SHO ENGINE

1989-90 Vehicles

1. Apply the parking brake, turn the A/C control selector OFF, then block the wheels.
2. Connect a tachometer and an inductive timing light to the engine. Start the engine and allow it to reach normal operating temperatures.
3. Unplug the Spark Output (SPOUT) line at the distributor, then check and/or adjust the ignition timing to the specification listed on the underhood emission calibration decal.
4. Stop the engine and disconnect the PCV hose at the intake manifold. Plug the PCV hose. Remove the Canister Purge Solenoid (CANP) hose from the intake manifold, then connect tool No. T89P-9600-AH or equivalent, between the PCV and CANP ports.

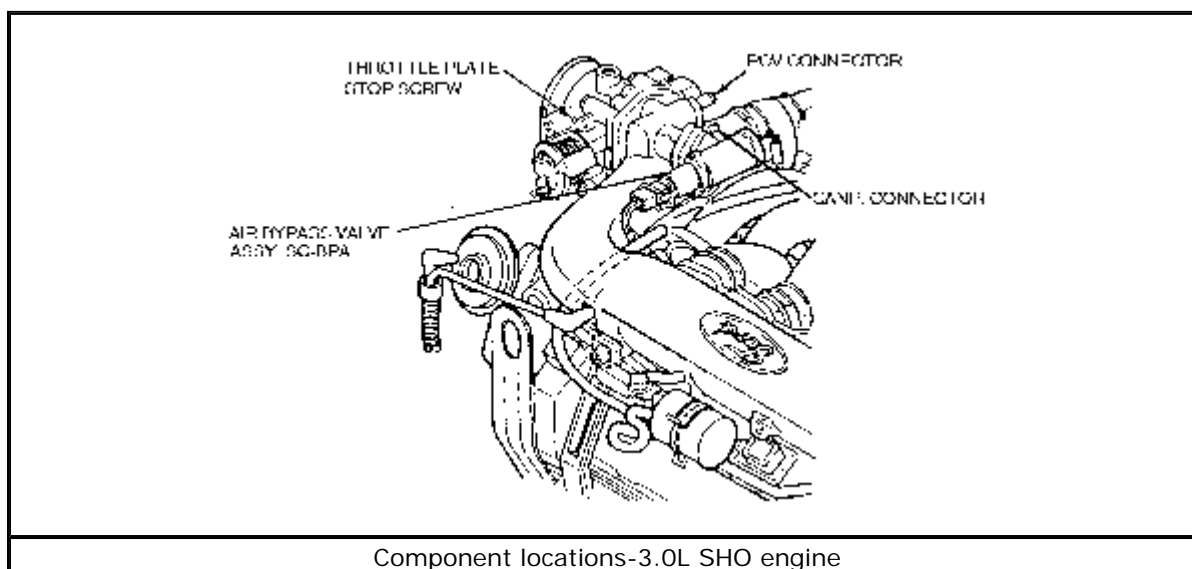

[Click to enlarge](#)

5. Disconnect the idle speed control/air bypass solenoid.
6. Start the engine and let it idle. Place the transaxle selector lever in N.
7. Check and/or adjust the idle speed to 770-830 rpm by turning the throttle plate stop screw.
8. Turn the engine OFF, then repeat Steps 6 and 7.
9. Stop the engine and remove all test equipment. Remove tool T89P-9600-AH or equivalent, then unplug the PCV hose. Connect the PCV and CANP hoses. Reconnect the idle speed control/air bypass solenoid.
10. Make sure the throttle is not stuck in the bore and the linkage is not preventing the throttle from closing.

3.8L ENGINE

1988 Vehicles

1. Apply the parking brake, block the drive wheels and place the vehicle in P (AT) or N (MT).
2. Start the engine and let it run until it reaches normal operating temperature, then turn the engine OFF.
3. Connect an inductive tachometer, then start the engine and run it at 2,500 rpm for 30 seconds.
4. Allow the engine idle to stabilize, then place the automatic transaxle in P or the manual transaxle in neutral.
5. Adjust the engine idle rpm to the specification shown on the vehicle emission calibration label by turning the throttle stop screw.
6. After the idle speed is within specification, repeat Steps 3-6 to ensure that the adjustment is correct.
7. Turn the engine OFF, then disconnect the test equipment and unblock the wheels.

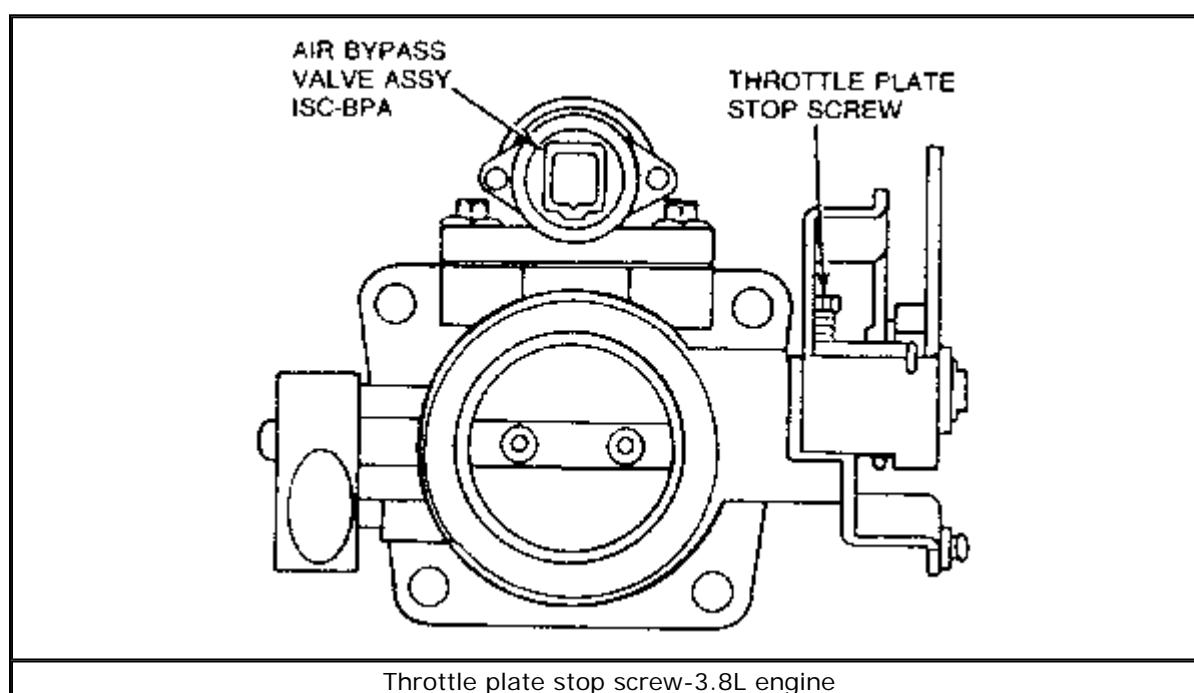

[Click to enlarge](#)

1989-90 Vehicles

1. Apply the parking brake, block the drive wheels, and place the vehicle in P.
2. Start the engine and let it run until it reaches normal operating temperature, then turn the engine OFF.
3. Back the throttle plate stop screw clear off the throttle lever pad.
4. Place a 0.010 in. (0.25mm) feeler gauge between the throttle plate stop screw and the throttle lever pad. Turn the screw in until contact is made, then turn it and additional $1\frac{1}{2}$ turns. Remove the feeler gauge.
5. Start the engine and let the idle stabilize for 2 minutes. Lightly depress and release the accelerator, then let the engine idle.

Idle Mixture Adjustment

Idle mixture is controlled by the electronic control unit. No adjustment is possible.

Chilton® Automotive Information Systems. © 2004 Thomson Delmar Learning.

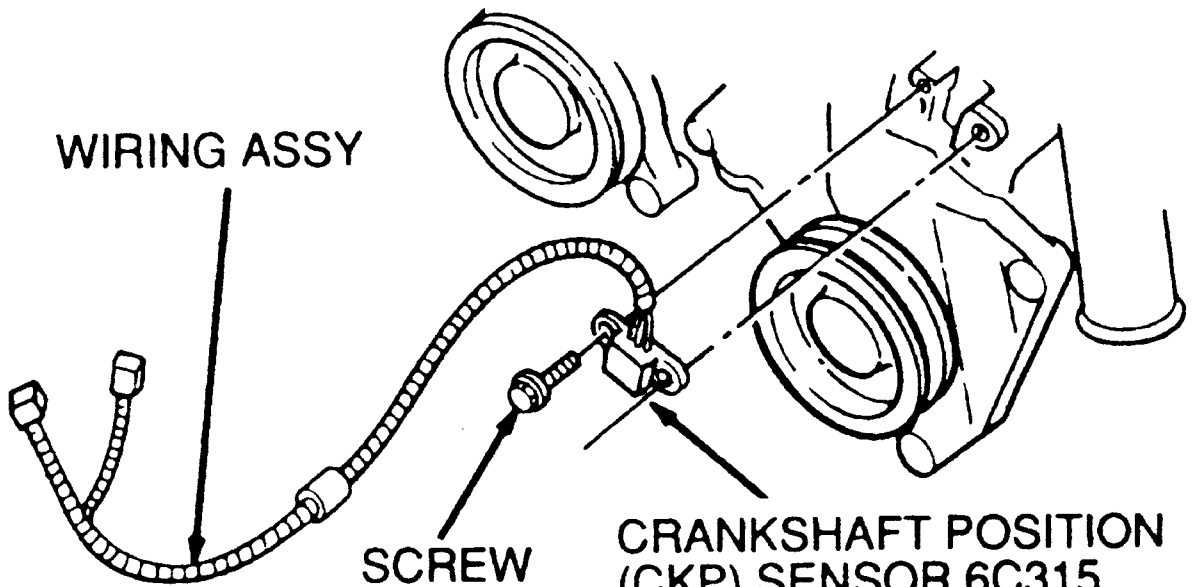

WIRING ASSY

SCREW
2 REQ'D
TIGHTEN TO
2.5-3.5 N·m
(22-31 LB-IN)

CRANKSHAFT POSITION
(CKP) SENSOR 6C315

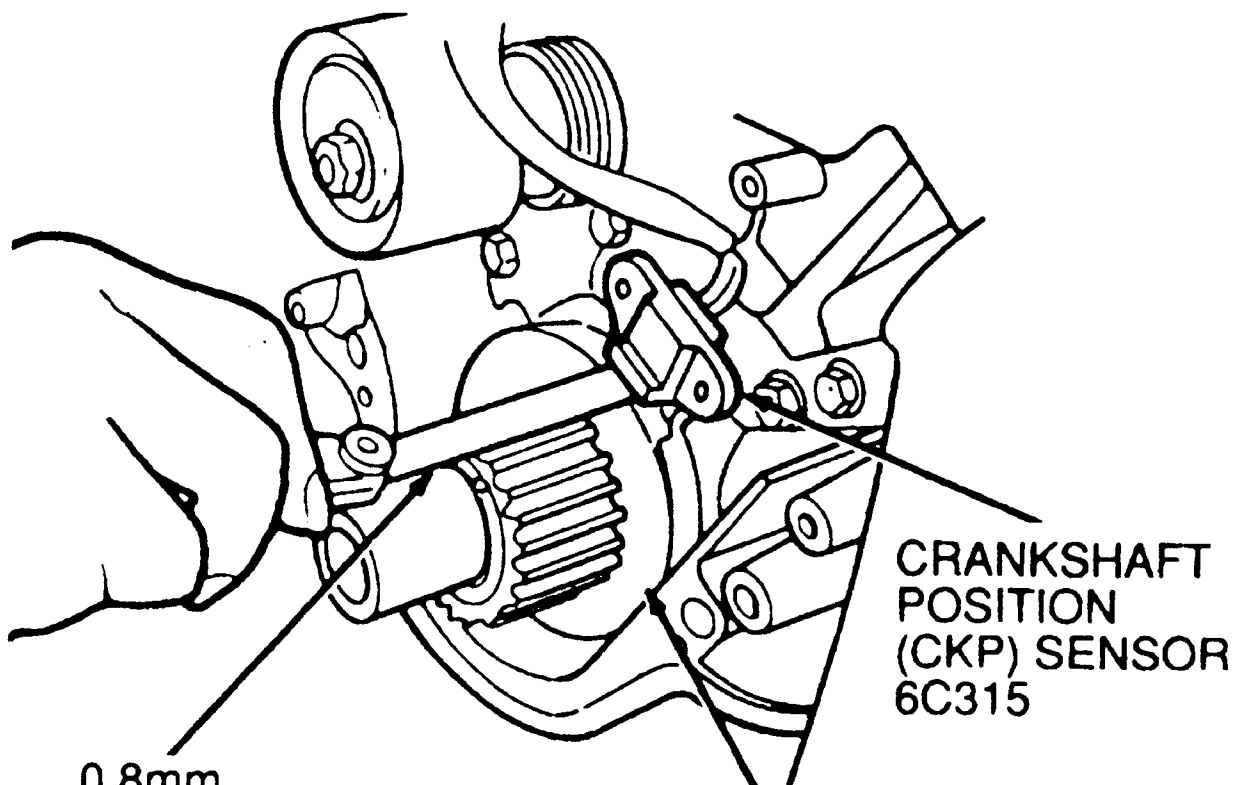

0.8mm
(0.03 in.)
FEELER GAUGE

CRANKSHAFT
SPROCKET 6306

CRANKSHAFT
POSITION
(CKP) SENSOR
6C315

FRONT OF
ENGINE

BOLT
2 REQ'D
TIGHTEN TO
2.5-3.5 N·m
(22-31 LB-IN)

CONNECTOR

CAMSHAFT POSITION
(CMP) SENSOR 12126

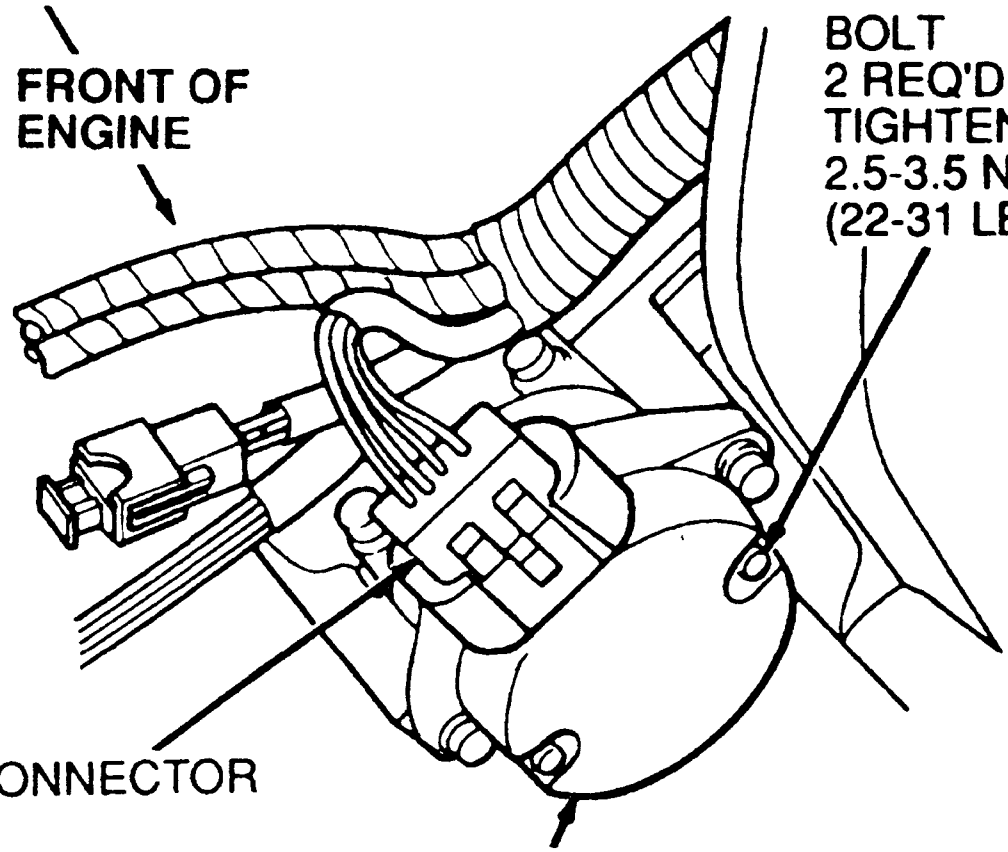

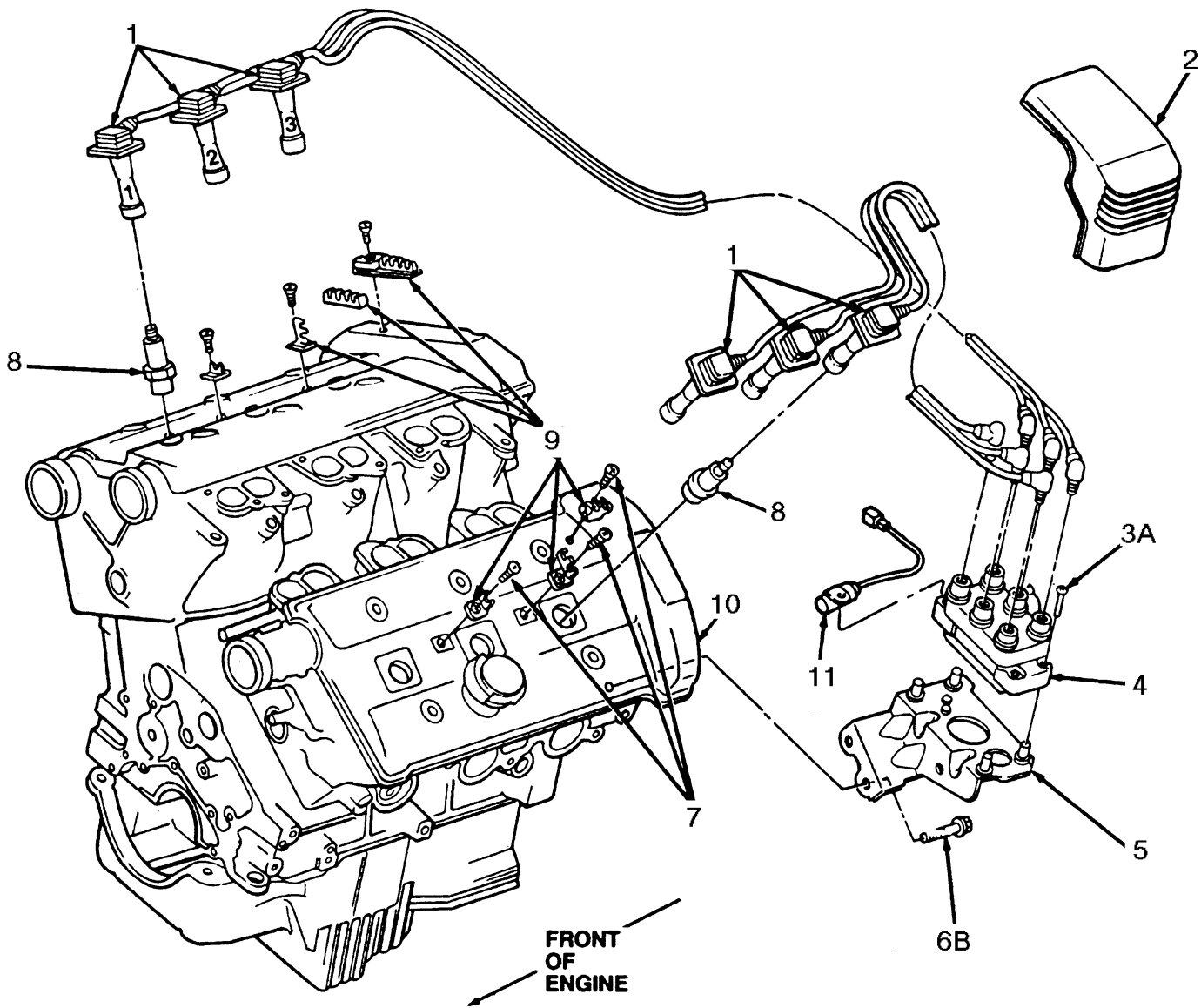

- 1 Ignition wire (6 req'd)
- 2 Ignition coil cover
- 3 Screw (4 req'd)
- 4 Ignition coil
- 5 Ignition coil bracket
- 6 Bolt (2 req'd)
- 7 Screw (3 req'd each side)

- 8 Spark plug (6 req'd)
- 9 Ignition wire separator
- 10 Valve cover
- 11 Radio ignition interference capacitor
- A Tighten to 4.5-7.0 Nm (40-62 lb.in.)
- B Tighten to 28-42 Nm (21-31 lb.ft.)

**BOLT
4 REQ'D
TIGHTEN TO
2.5-3.5 N·m
(22-31 LB-IN)**

**ENGINE AIR
INLET CONNECTOR
9C674**

**IGNITION CONTROL
MODULE (ICM) 12A297**

**APPLY A UNIFORM COATING
OF SILICONE DIELECTRIC
COMPOUND D7AZ-19A331-A
(MOTORCRAFT WA-10) OR
EQUIVALENT MEETING FORD
SPECIFICATION ESE-M1C171-A
TO BOTTOM SURFACE OF
IGNITION CONTROL MODULE
PRIOR TO ASSY**

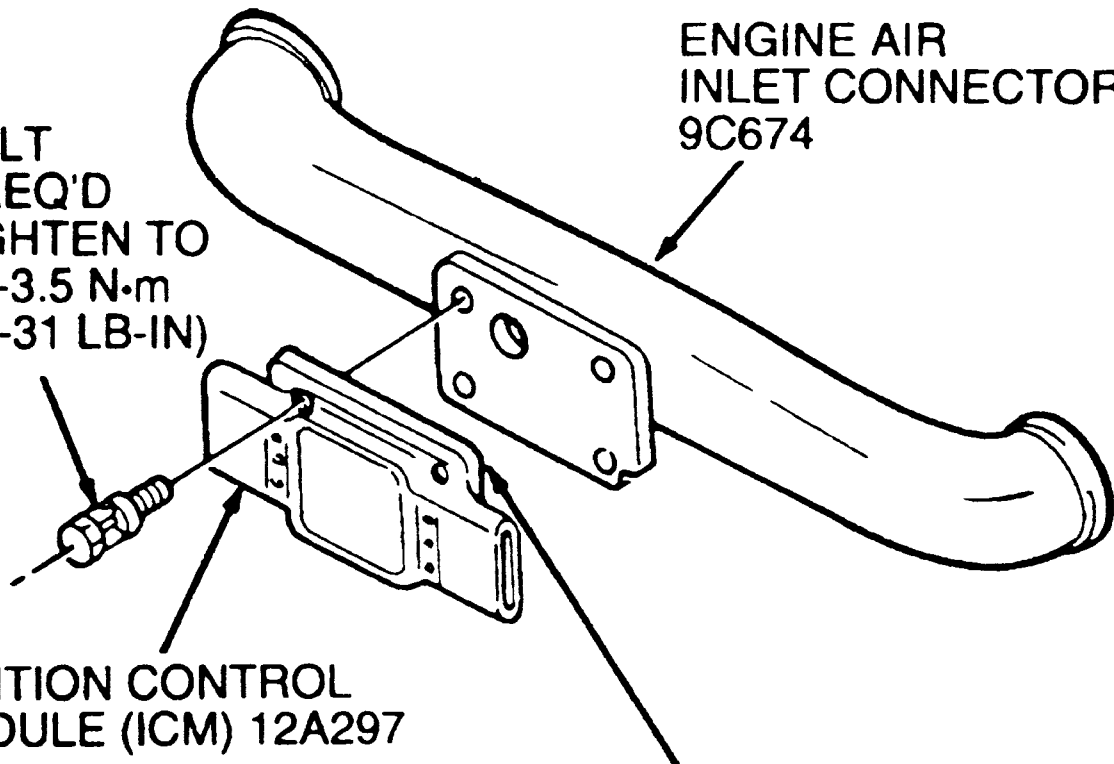

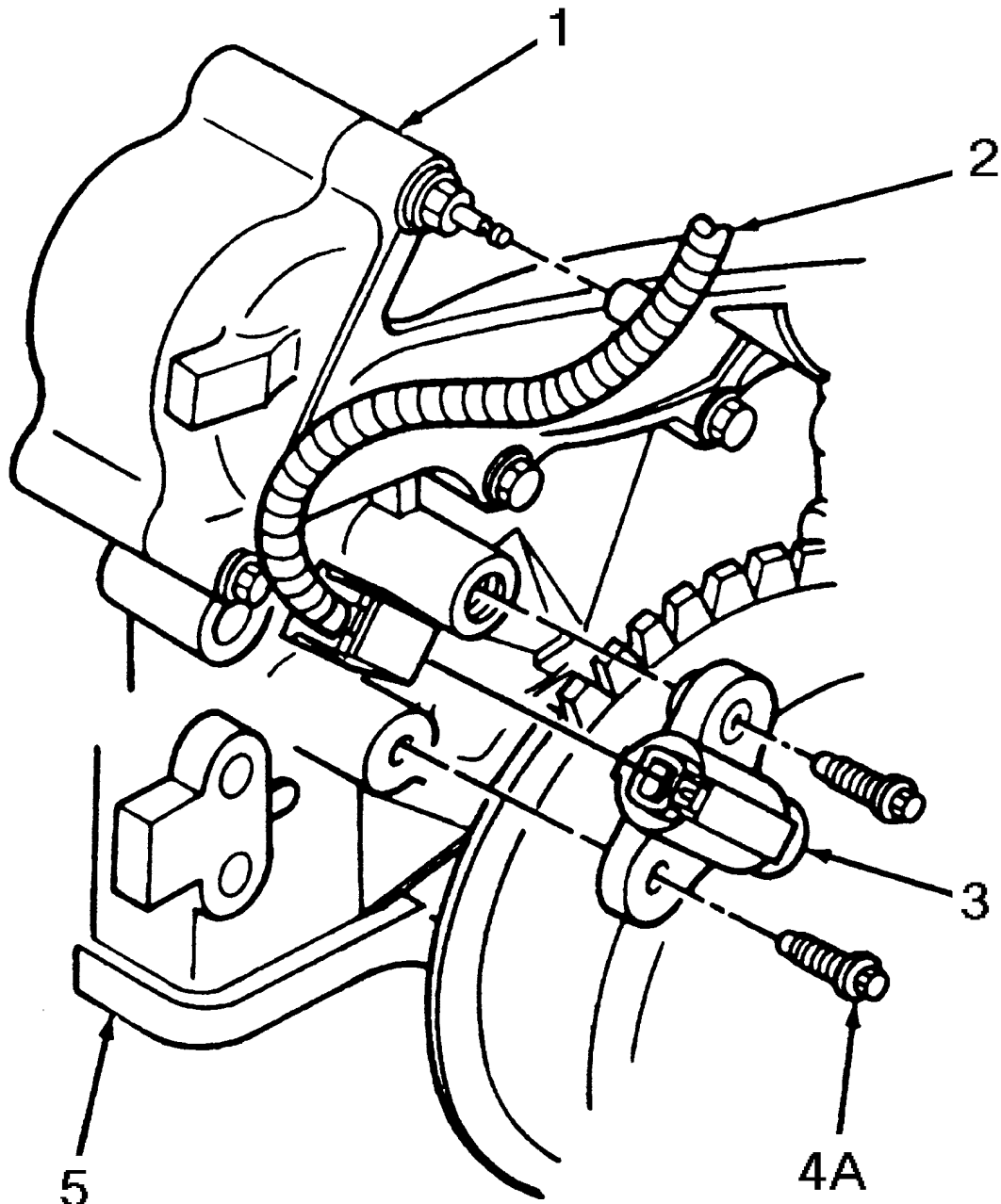

- 1 Water pump
- 2 Fuel charging wiring
- 3 Crankshaft position sensor
- 4 Bolt (2 req'd)
- 5 Engine front cover
- A Tighten to 5-7 Nm (44-61 lb.in.)

FRONT OF ENGINE

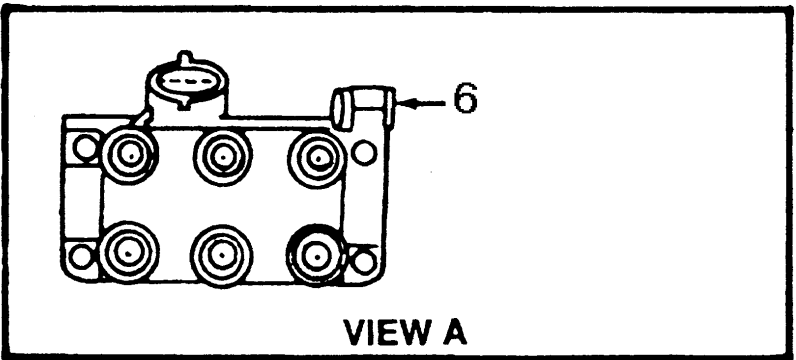
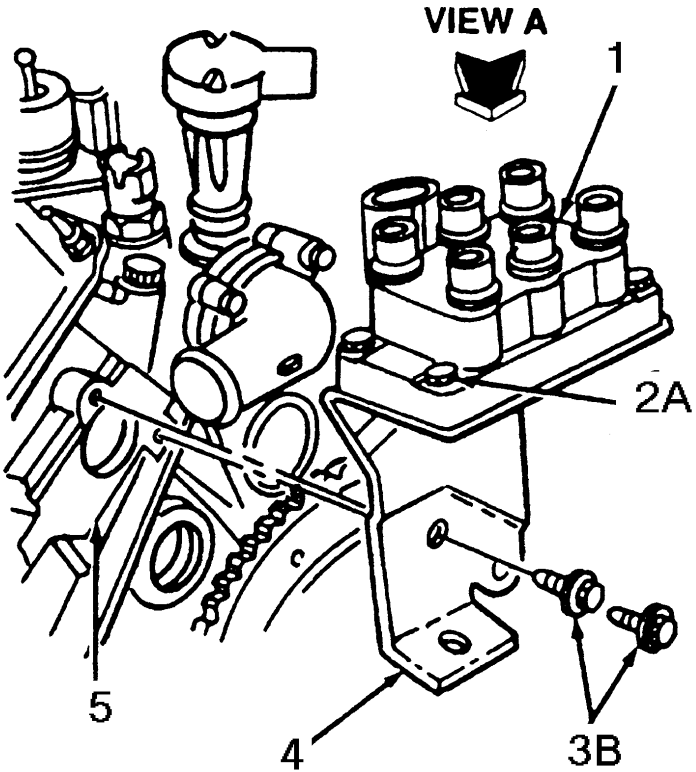

- 1 Ignition coil
- 2 Screw (4 req'd)
- 3 Bolt (2 req'd)
- 4 Ignition coil mounting bracket
- 5 Cylinder head (LH)
- 6 Radio ignition interference capacitor
- A Tighten to 4.5-7.0 Nm (44-61 lb.in.)
- B Tighten to 40-55 Nm (30-41 lb.ft.)

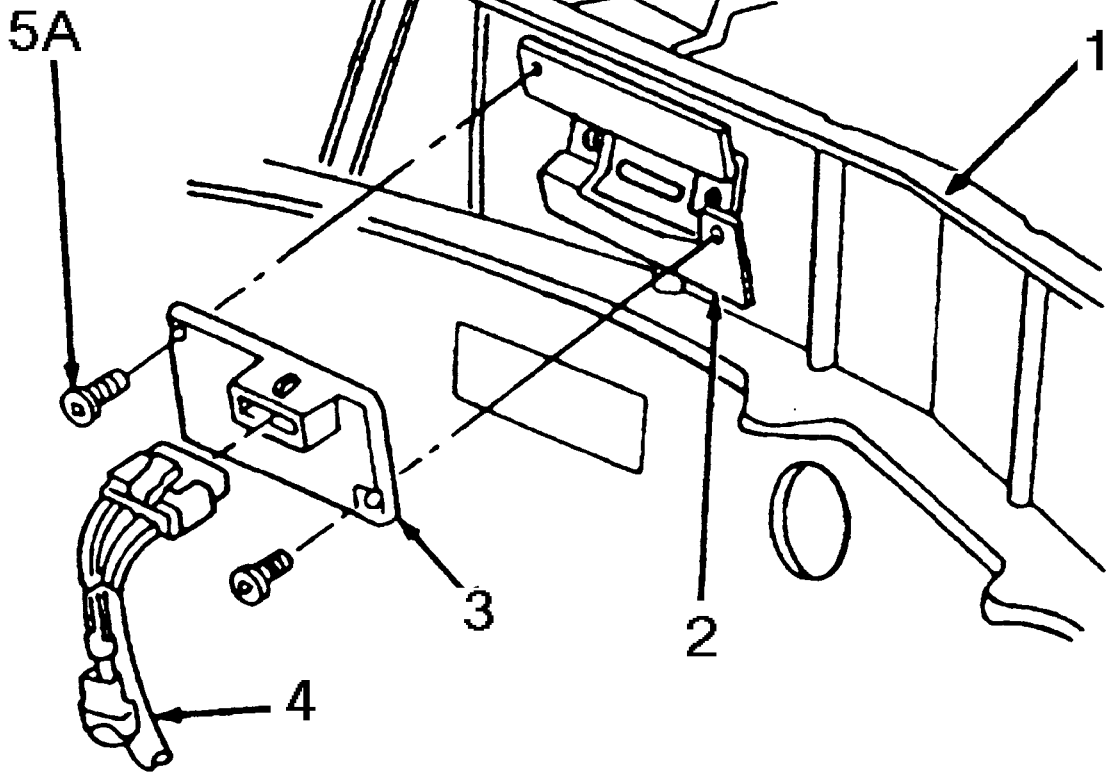

- 1 Dash panel
- 2 Ignition control module bracket
- 3 Ignition control module
- 4 Engine control sensor wiring
- 5 Screw (2 req'd)
- A Tighten to 2.7-3.7 Nm (24-32 lb.in.)

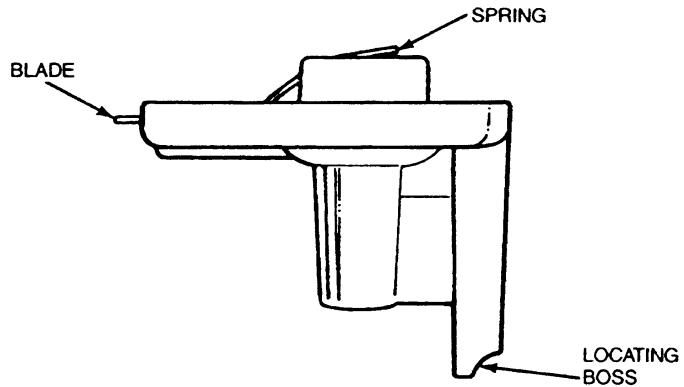
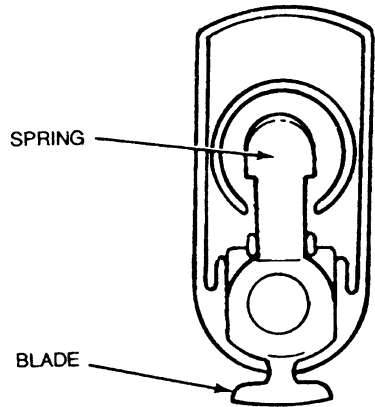

**4-CYLINDER SHOWN
6-CYLINDER TYPICAL**

**CRACK OR
CARBON
TRACK**

**SQUARE
ALIGNMENT
LOCATOR**

**CARBON
BUTTON**

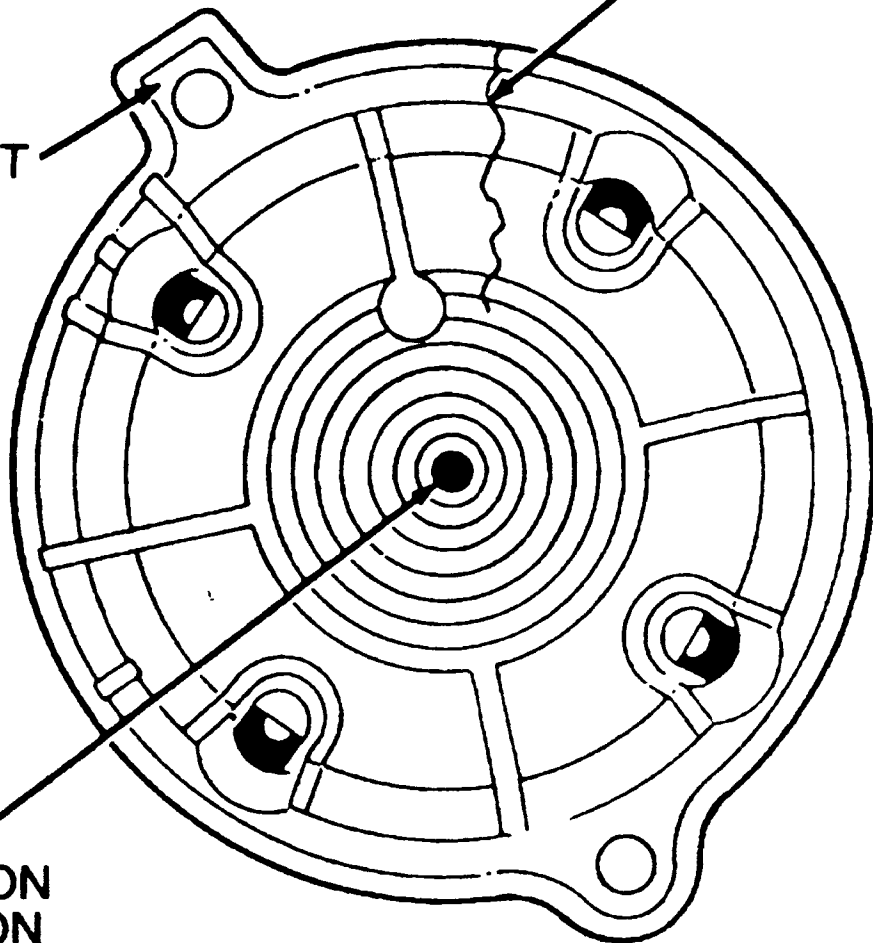

DISTRIBUTOR CAP

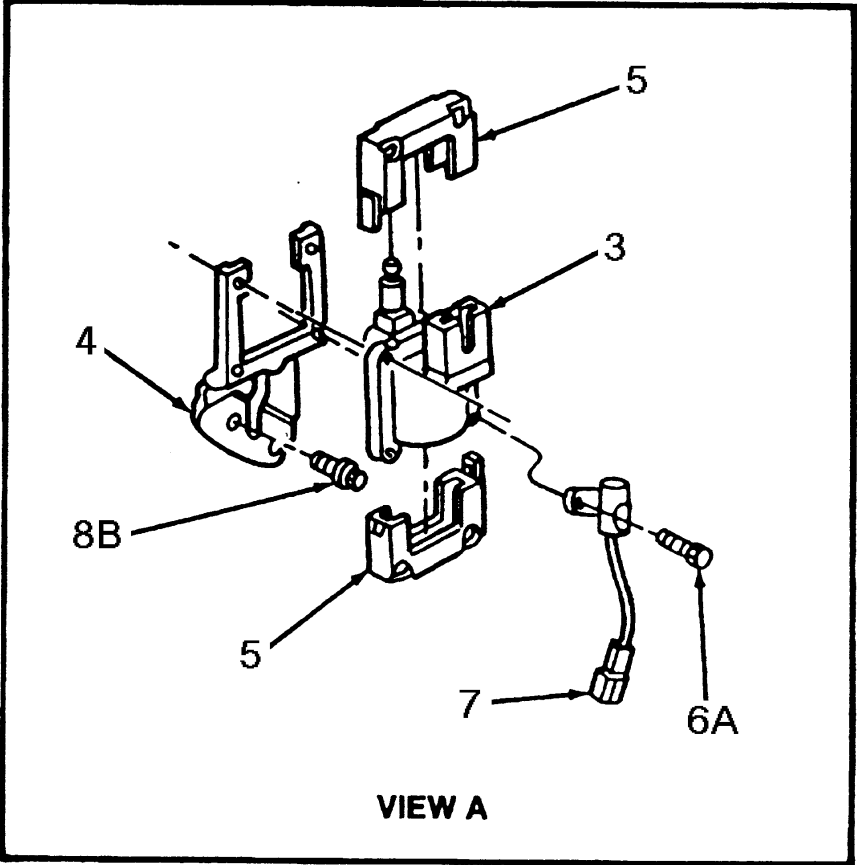

- 1 Ignition coil to distributor high tension wiring
- 2 Distributor cap
- 3 Ignition coil
- 4 Ignition coil mounting bracket
- 5 Ignition coil cover

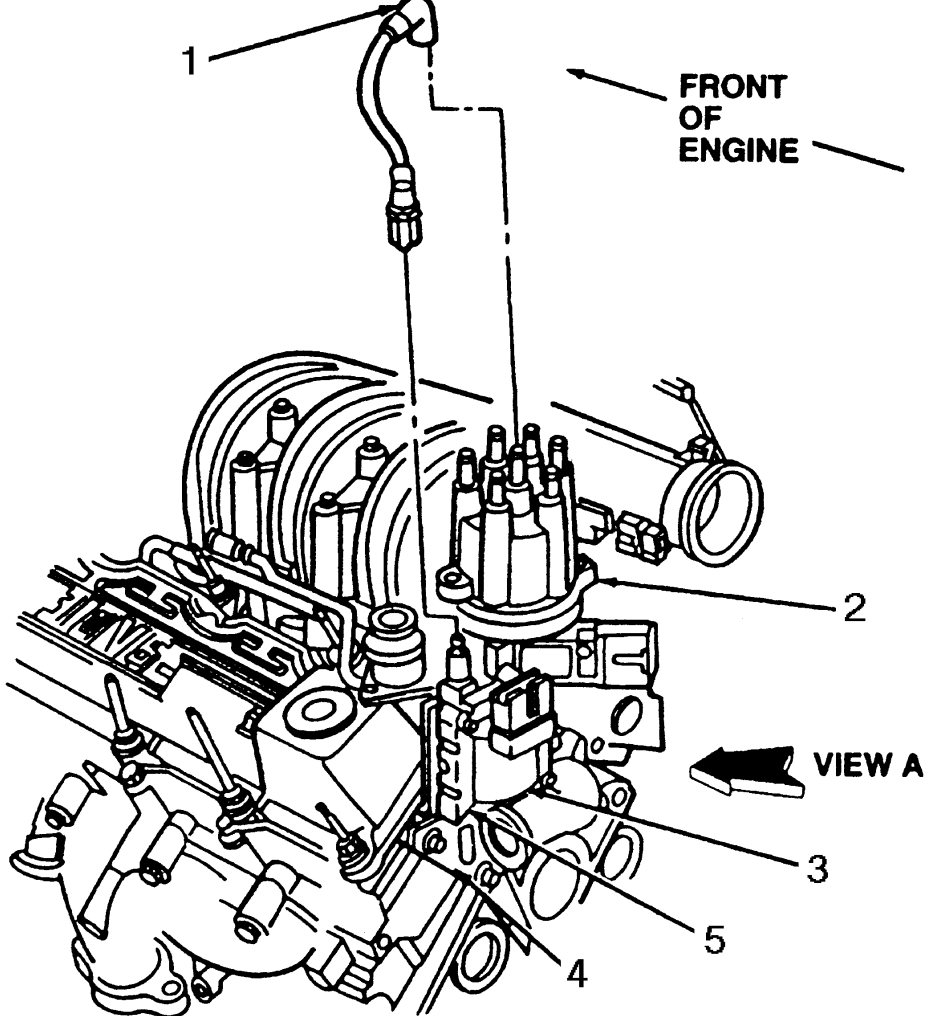

- 6A Screw (4 req'd)
- 7 Radio ignition interference capacitor
- 8B Bolt (2 req'd)
- A Tighten to 2.8-4.0 Nm (25-35 lb.in.)
- B Tighten to 20-30 Nm (15-22 lb.ft.)

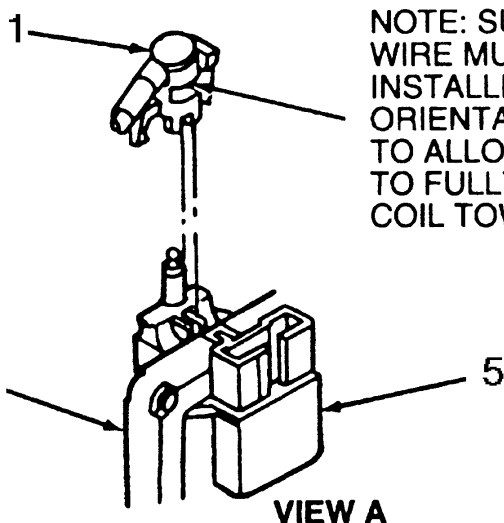
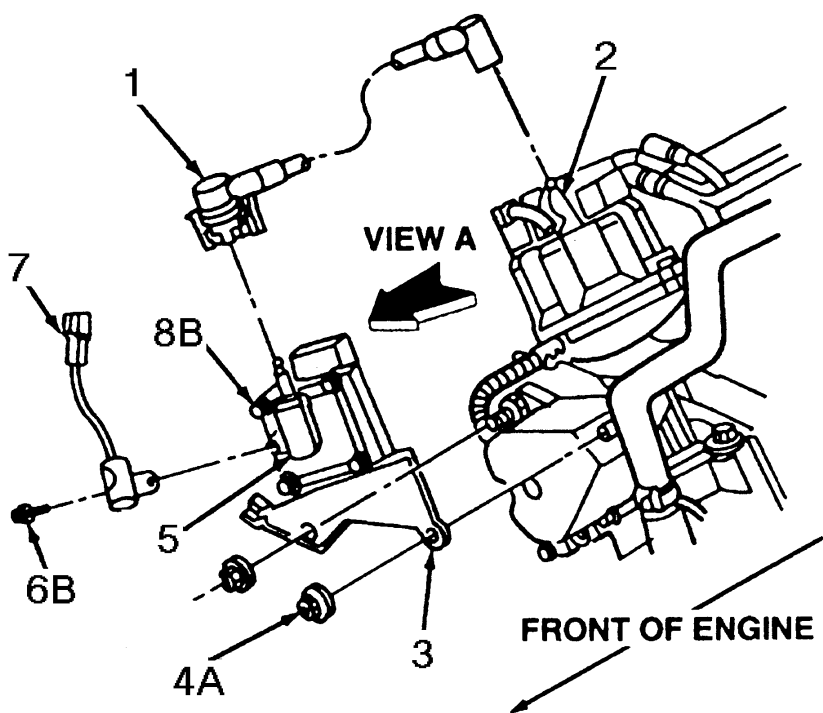

NOTE: SUPPRESSOR WIRE MUST BE INSTALLED AT ORIENTATION SHOWN TO ALLOW RETAINER TO FULLY ENGAGE COIL TOWER

- 1 Ignition coil to distributor high tension wiring
- 2 Distributor cap
- 3 Ignition coil mounting bracket
- 4A Nut (2 req'd)
- 5 Ignition coil
- 6B Screw
- 7 Radio ignition interference capacitor
- 8B Screw (4 req'd)
- A Tighten to 40-50 Nm (30-41 lb.ft.)
- B Tighten to 2.8-4.0 Nm (25-35 lb.in.)

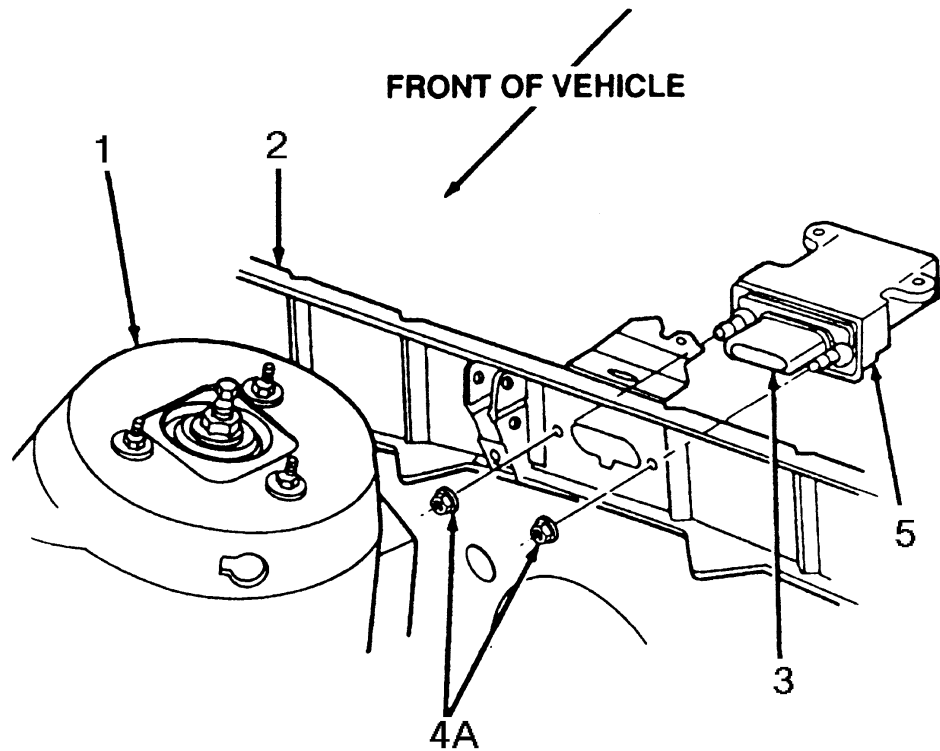

- 1 RH front fender apron
- 2 Dash panel
- 3 Ignition control module

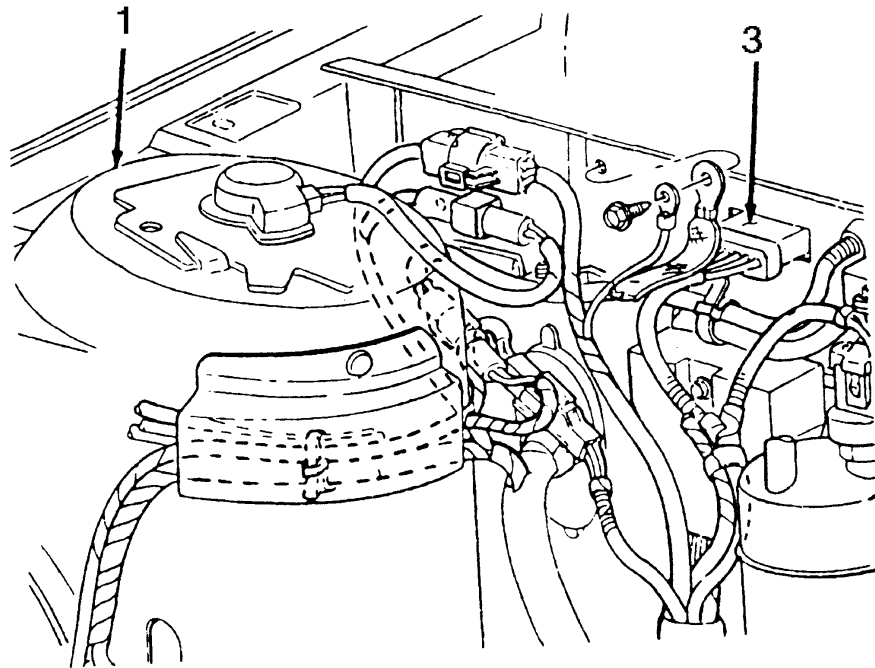

**INSTALLED
POSITION**

- 4 Retaining nuts (2 req'd)
- 5 Ignition control module heat sink
- A Tighten to 5-8 Nm (44-70 lb.in.)

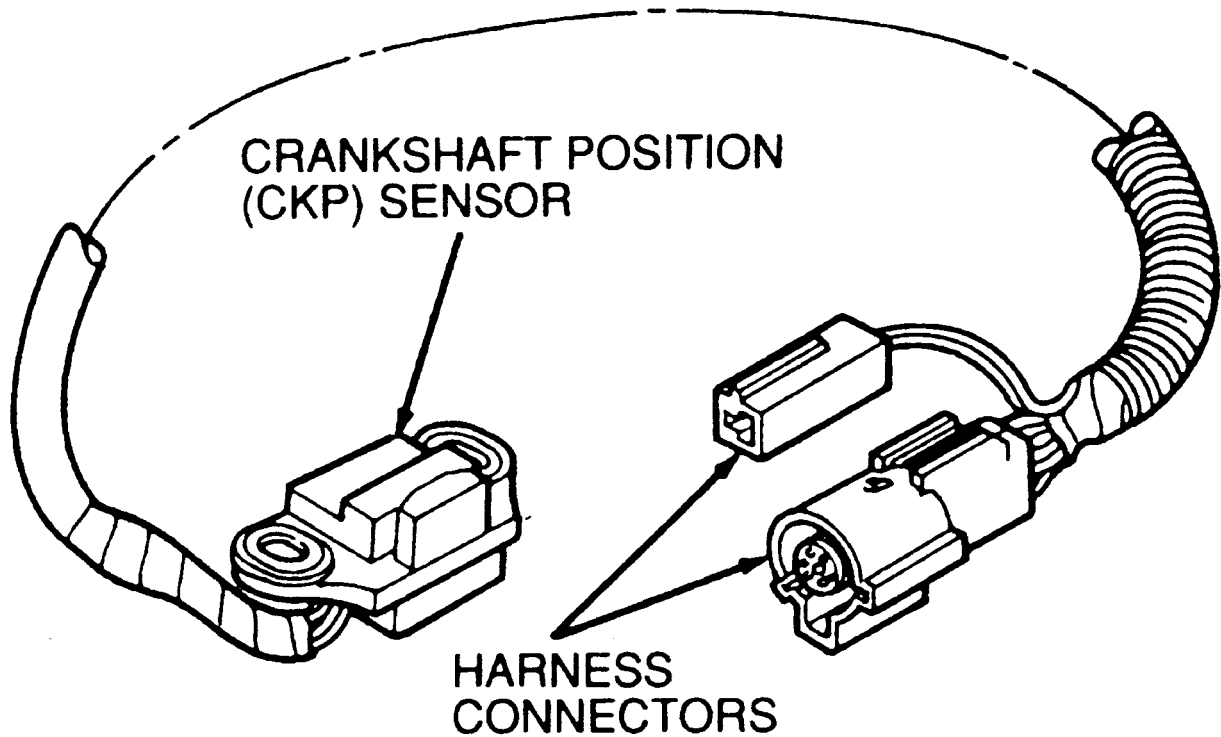

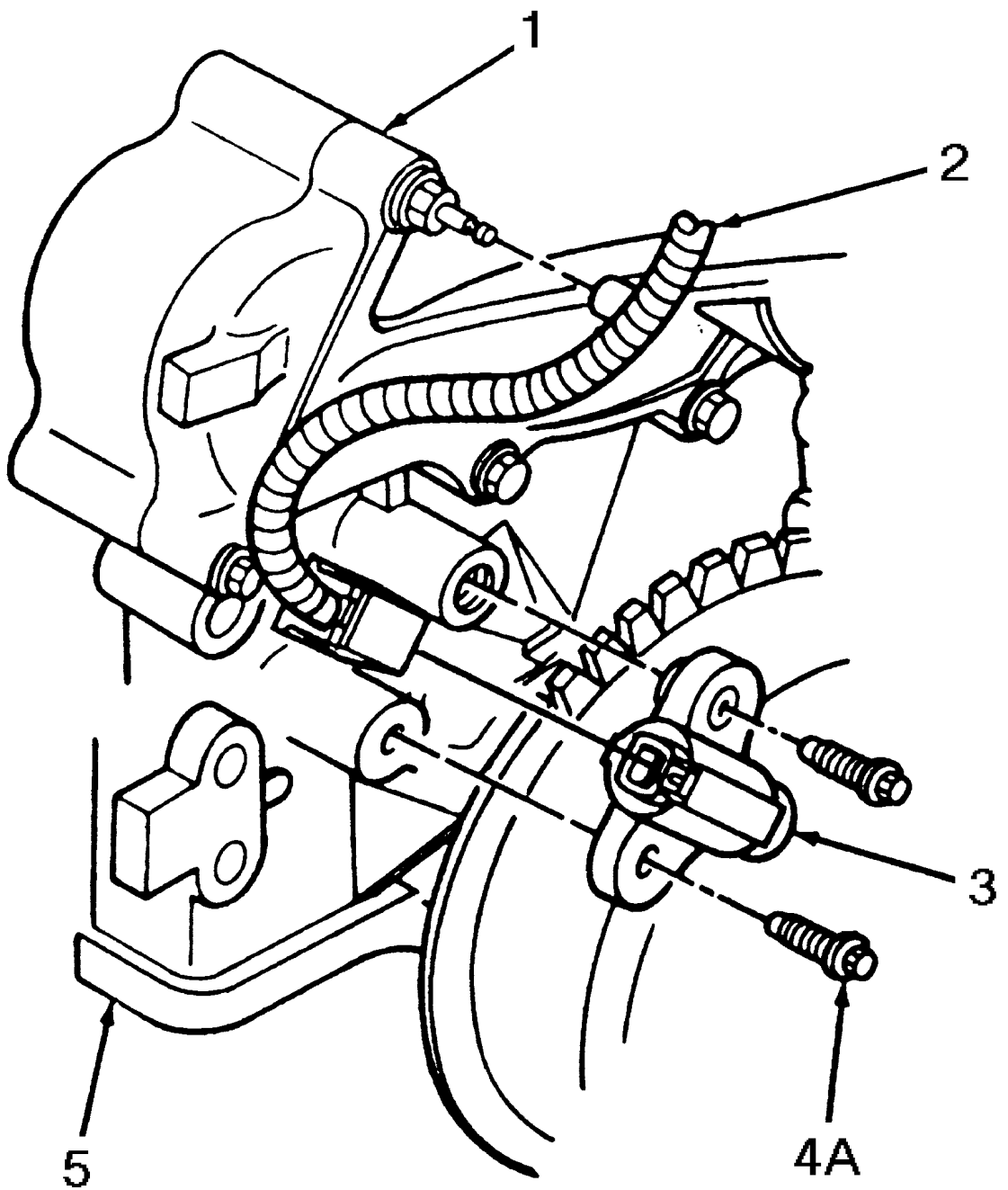

1 Water pump

2 Fuel charging wiring

3 Crankshaft position sensor

4 Bolt (2 req'd)

5 Engine front cover

A Tighten to 5-7 Nm (44-61 lb.in.)

HIGH VOLTAGE TOWERS

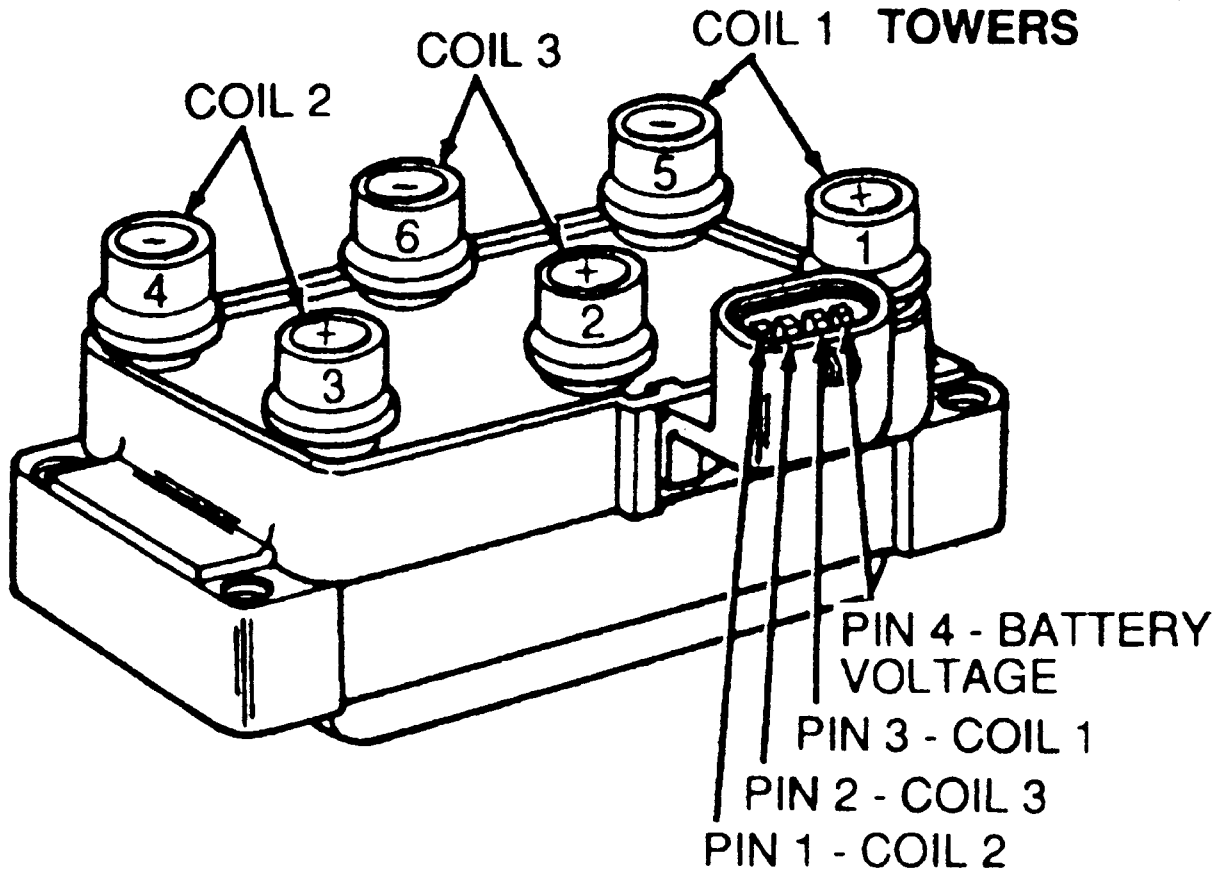

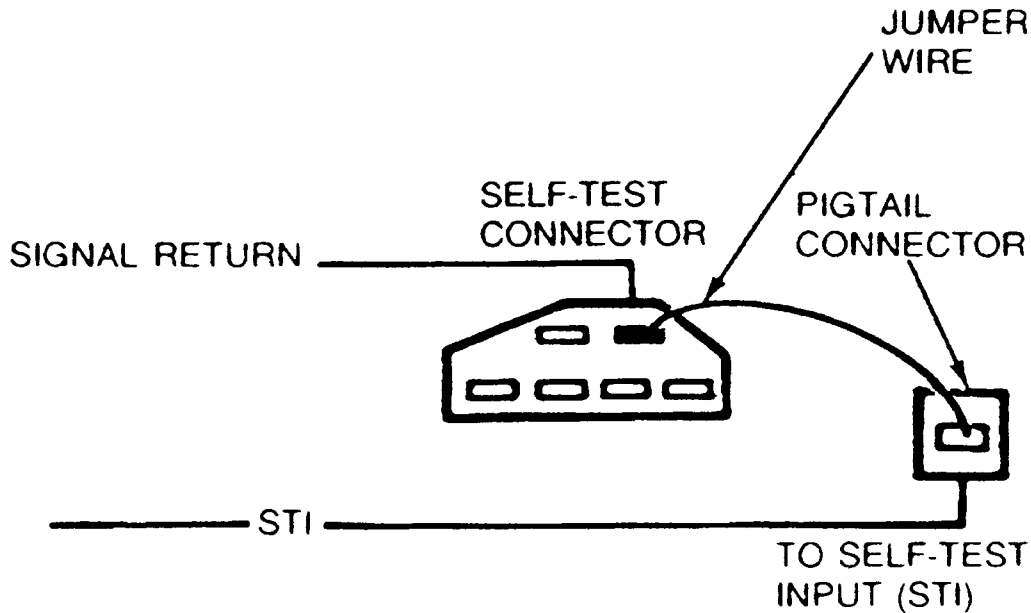

IDLE SPEED CONTROL
(ISC) CONNECTOR

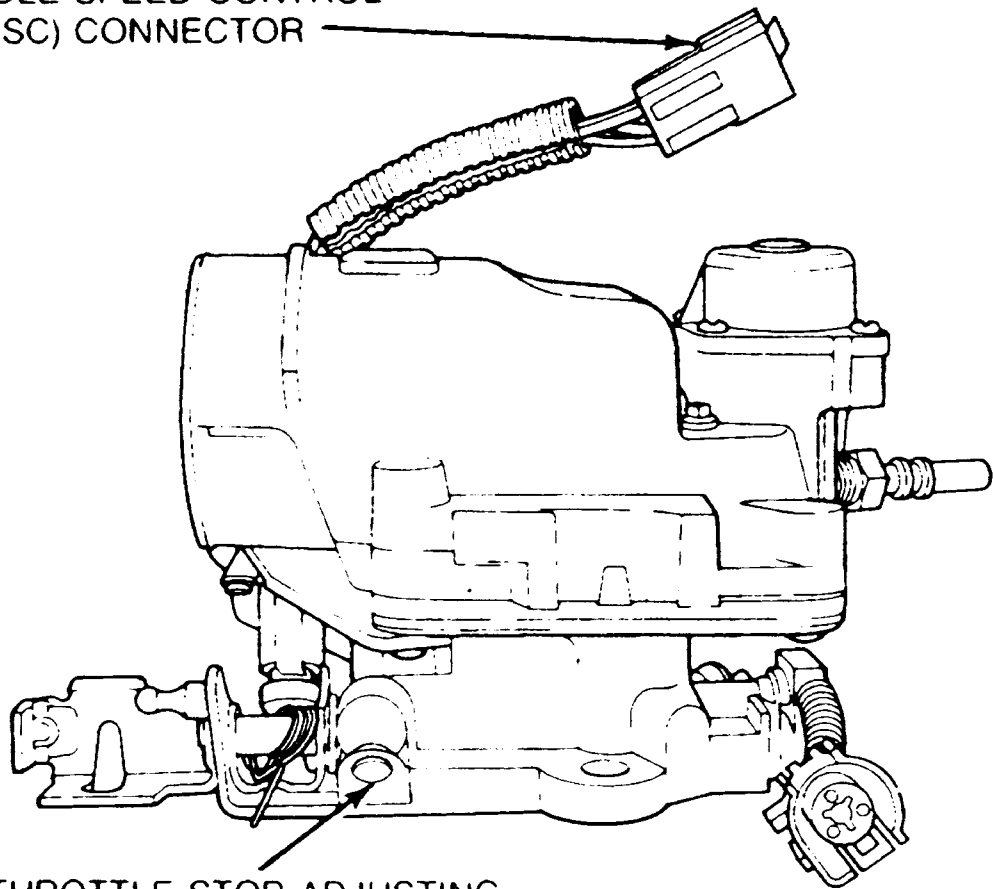

THROTTLE STOP ADJUSTING
SCREW (TAMPER RESISTANT CAP)

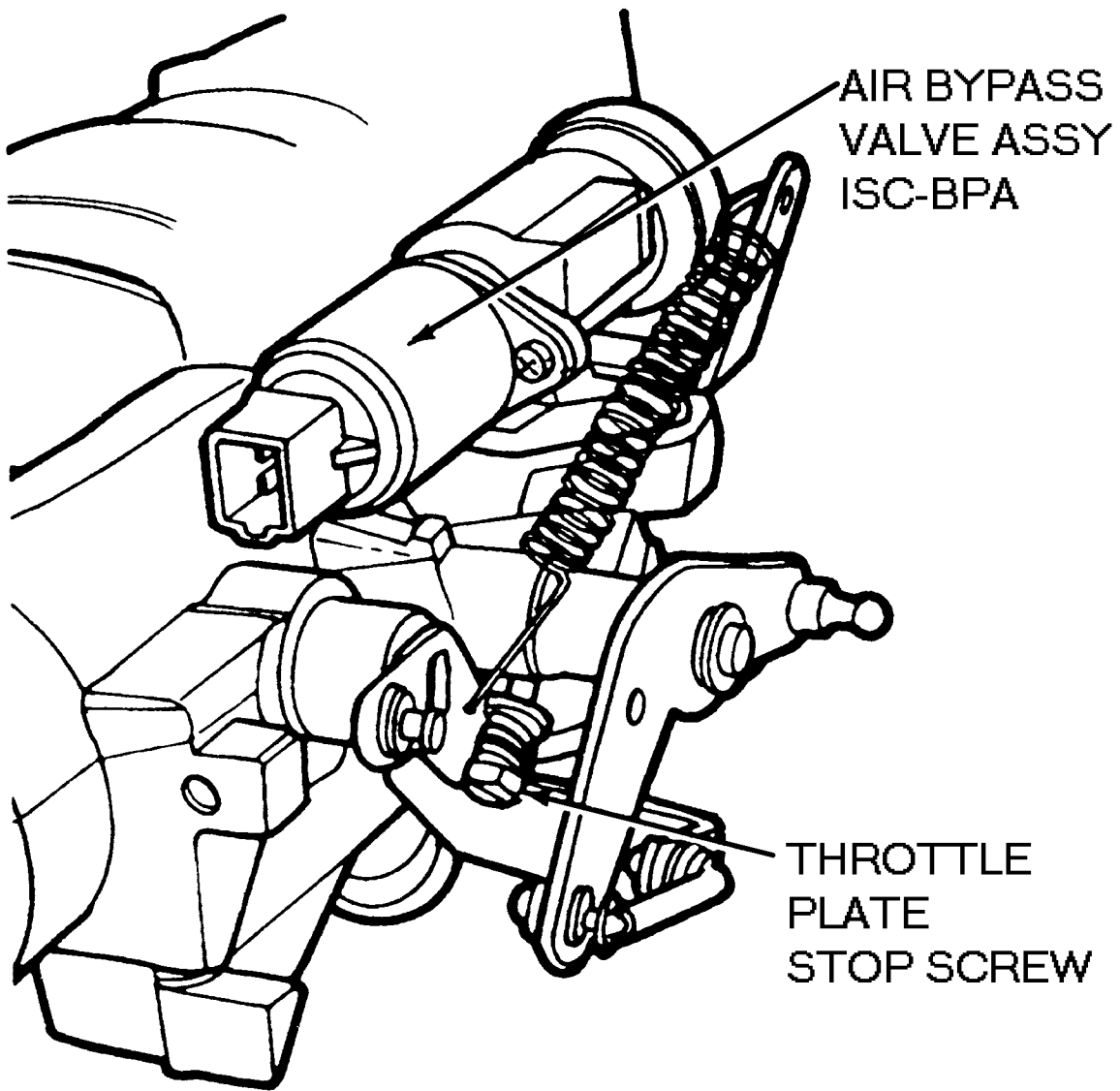

AIR BYPASS
VALVE ASSY
ISC-BPA

THROTTLE
PLATE
STOP SCREW

THROTTLE PLATE
STOP SCREW

PCV CONNECTOR

CANP. CONNECTOR

AIR BYPASS VALVE
ASSY ISC-BPA

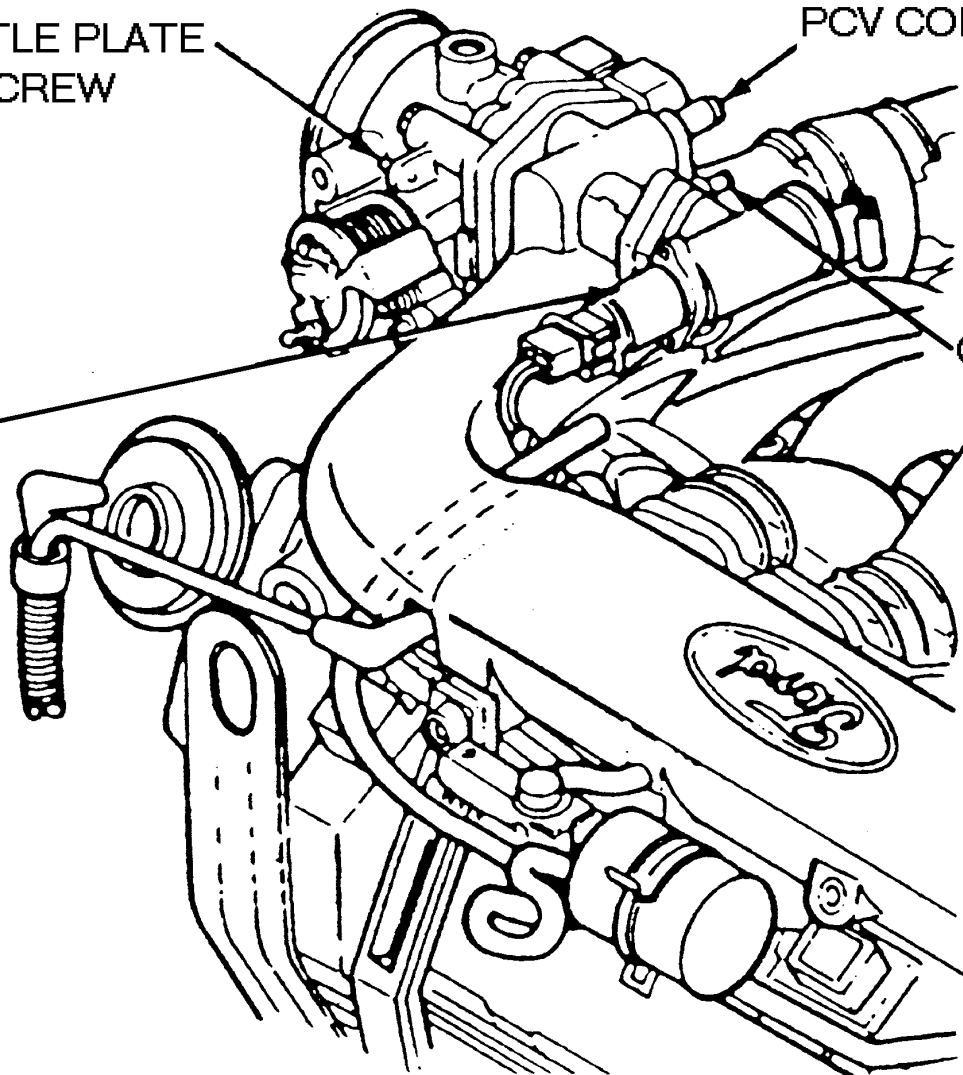

AIR BYPASS
VALVE ASSY
ISC-BPA

THROTTLE PLATE
STOP SCREW

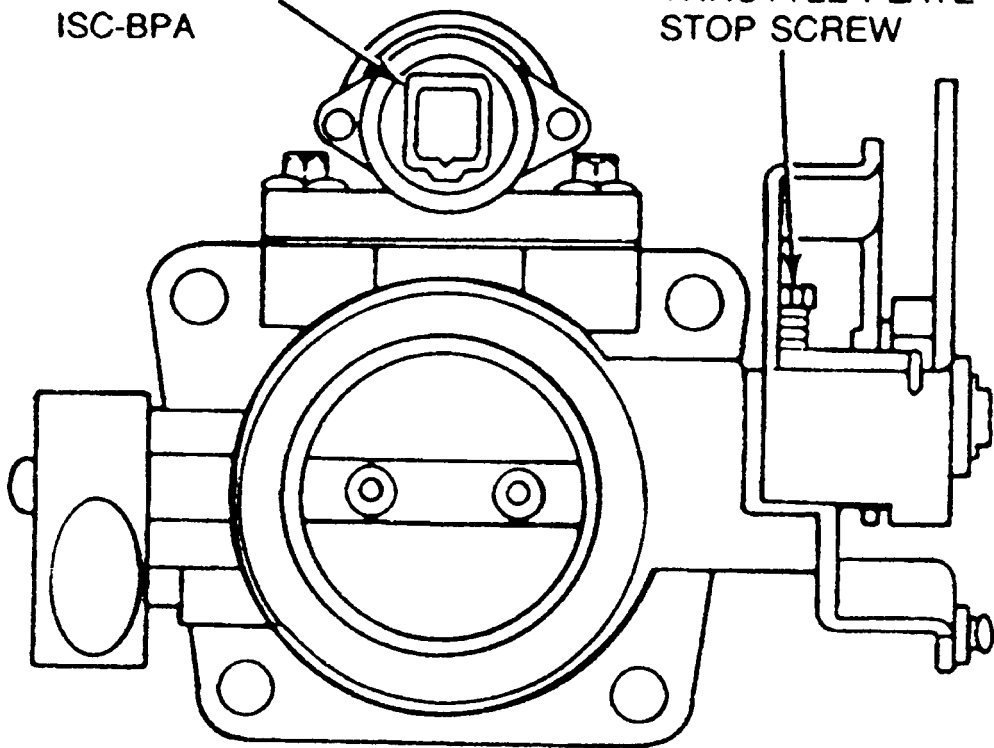

COVER PLATE

COOLANT
TEMPERATURE SWITCH

TIMING POINTER

TIMING SLOT
IN TRANS.
CASE

CENTER OF ENGINE

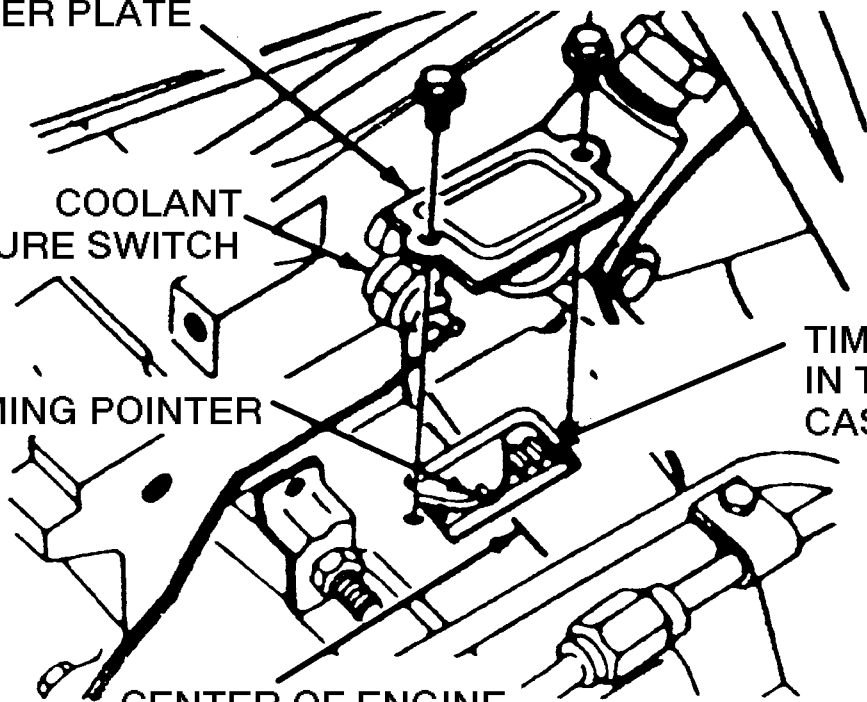

INDEX ON BELT COVER

WHITE - TDC MARK

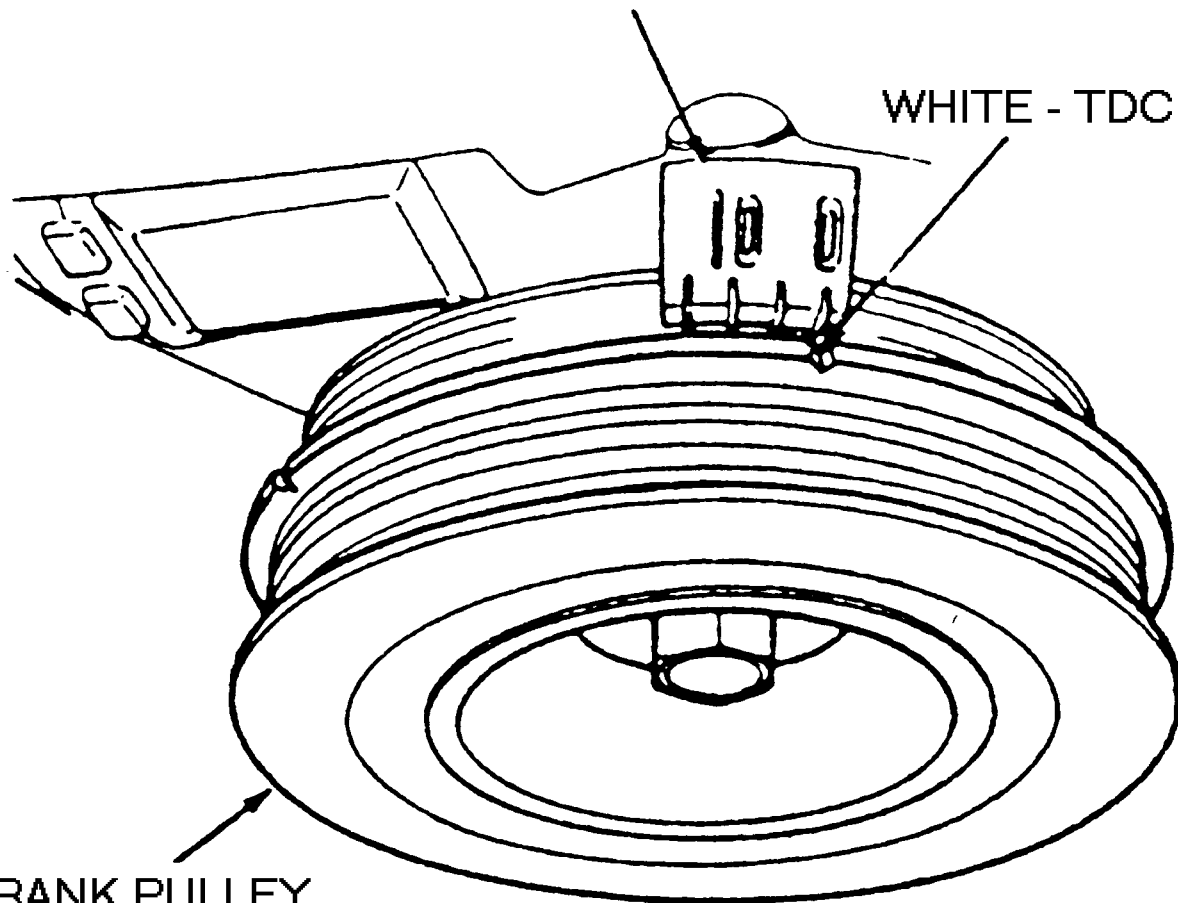

CRANK PULLEY

INDEX ON BELT COVER

WHITE - TDC MARK

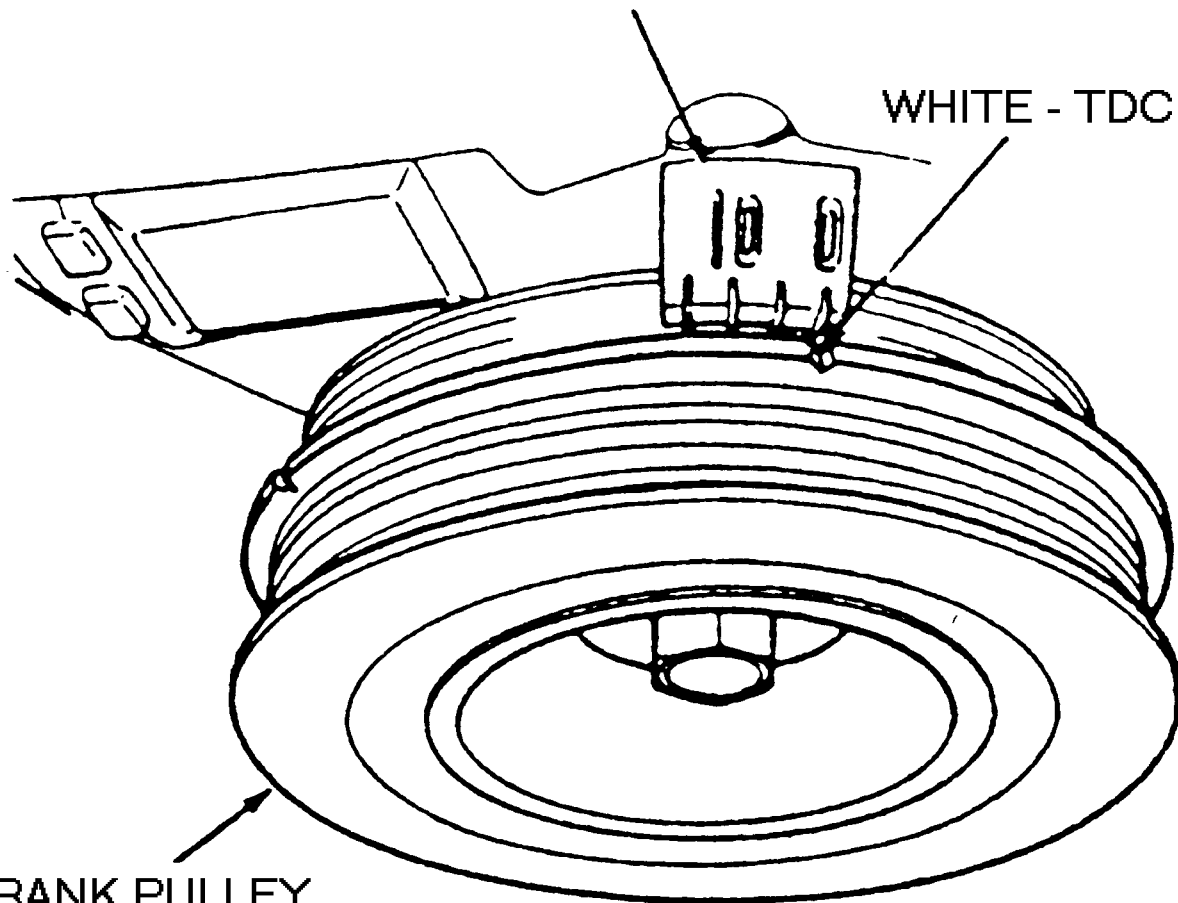

CRANK PULLEY

GASOLINE ENGINE TUNE-UP SPECIFICATIONS

Year	Engine ID/VIN	Engine Displacement Liters (cc)	Spark Plugs Gap (in.)	Ignition Timing (deg.)		Fuel Pump (psi)	Idle Speed (rpm)		Valve Clearance	
				MT	AT		MT	AT	In.	Ex.
1986	D	2.5 (2501)	0.044	10B	10B	13-17	725	650	HYD	HYD
	U	3.0 (2980)	0.044	-	10B	35-45	-	625	HYD	HYD
1987	D	2.5 (2501)	0.044	10B	10B	13-17	725	650	HYD	HYD
	U	3.0 (2980)	0.044	-	10B	35-45	-	625	HYD	HYD
1988	D	2.5 (2501)	0.044	10B	10B	13-17	725	650	HYD	HYD
	U	3.0 (2971)	0.044	-	10B	35-45	-	625	HYD	HYD
	4	3.8 (3802)	0.044	-	10B	35-45	-	550	HYD	HYD
1989	D	2.5 (2501)	0.044	10B	10B	35-45	725	650	HYD	HYD
	U	3.0 (2980)	0.052	-	10B	35-45	-	625	HYD	HYD
	Y	3.0 (2980)	0.044	10B	-	36-39	800	-	0.006- 0.01	0.010- 0.014
	4	3.8 (3802)	0.054	-	10B	35-45	-	550	HYD	HYD
1990	D	2.5 (2501)	0.044	10B	10B	35-45	725	650	HYD	HYD
	U	3.0 (2980)	0.044	-	10B	35-45	-	625	HYD	HYD
	Y	3.0 (2980)	0.044	10B	-	36-39	800	-	0.006- 0.010	0.010- 0.014
	4	3.8 (3802)	0.054	-	10B	35-45	-	550	HYD	HYD
1991	D	2.5 (2501)	0.044	10B	10B	45-60	725	650	HYD	HYD
	U	3.0 (2980)	0.044	-	10B	35-45	-	625	HYD	HYD
	Y	3.0 (2980)	0.044	10B	-	36-39	800	-	0.006- 0.010	0.010- 0.014
	4	3.8 (3802)	0.054	-	10B	35-45	-	550	HYD	HYD
1992	U	3.0 (2980)	0.044	-	10B	35-40	-	625	HYD	HYD
	Y	3.0 (2980)	0.044	10B	-	30-45	800	-	0.006- 0.010	0.010- 0.014
	4	3.8 (3802)	0.054	-	10B	35-40	-	550	HYD	HYD
1993	U	3.0 (2980)	0.044	-	10B	35-45	-	625	HYD	HYD
	Y	3.0 (2980)	0.044	10B	-	30-45	800	-	0.006- 0.010	0.010- 0.014
	P	3.2 (3191)	0.044	-	10B	30-45	-	-	0.006- 0.010	0.010- 0.010
	4	3.8 (3802)	0.054	-	10B	35-45	-	550	HYD	HYD
1994	U	3.0 (2980)	0.044	-	10B	30-45 ²	1	1	HYD	HYD
	Y	3.0 (2980)	0.044	10B	-	28-33 ²	1	-	0.006- 0.010	0.010- 0.014
	P	3.2 (3191)	0.044	-	10B	28-33 ²	-	750	0.006- 0.010	0.010- 0.010
	4	3.8 (3802)	0.054	-	10B	30-45 ²	1	1	HYD	HYD
1995	U	3.0 (2980)	0.044	-	10B	30-45 ²	-	1	HYD	HYD
	Y	3.0 (2980)	0.044	10B	-	28-33 ²	1	-	0.006- 0.010	0.010- 0.014
	P	3.2 (3191)	0.044	-	10B	30-45 ²	-	800	0.006- 0.010	0.010- 0.014
	4	3.8 (3802)	0.054	-	10B	30-45 ²	-	1	HYD	HYD

NOTE: The Vehicle Emission Control Information label often reflects specification changes made during production. The label figures must be used if they differ from those in this chart.

B - Before top dead center

HYD - Hydraulic

¹ Refer to the Vehicle Emission Control Label

² Fuel Pressure with engine running, pressure regulator vacuum hose connected

Tracking Arc
 High voltage arcs between a fouling deposit on the insulator tip and spark plug shell. This ignites the fuel/air mixture at some point along the insulator tip, retarding the ignition timing which causes a power and fuel loss.

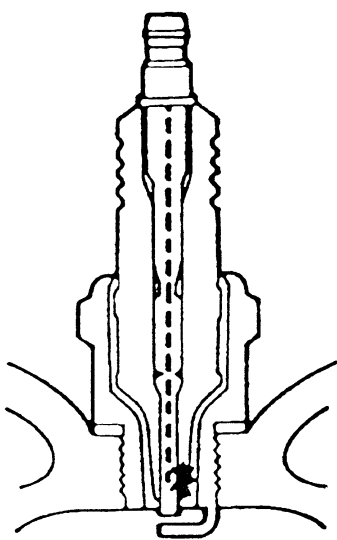

Wide Gap
 Spark plug electrodes are worn so that the high voltage charge cannot arc across the electrodes. Improper gapping of electrodes on new or "cleaned" spark plugs could cause a similar condition. Fuel remains unburned and a power loss results.

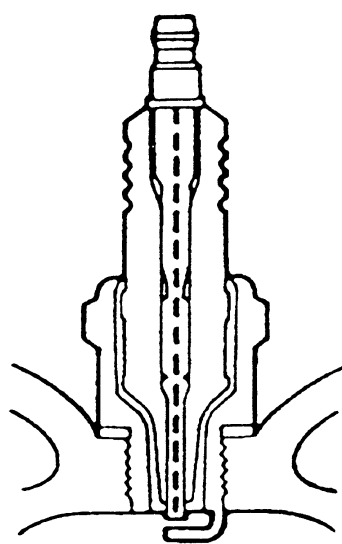

Flashover
 A damaged spark plug boot, along with dirt and moisture, could permit the high voltage charge to short over the insulator to the spark plug shell or the engine. A buttress insulator design helps prevent high voltage flashover.

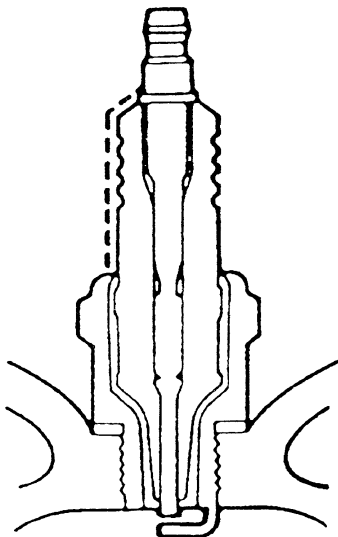

Fouled Spark Plug
 Deposits that have formed on the insulator tip may become conductive and provide a "shunt" path to the shell. This prevents the high voltage from arcing between the electrodes. A power and fuel loss is the result.

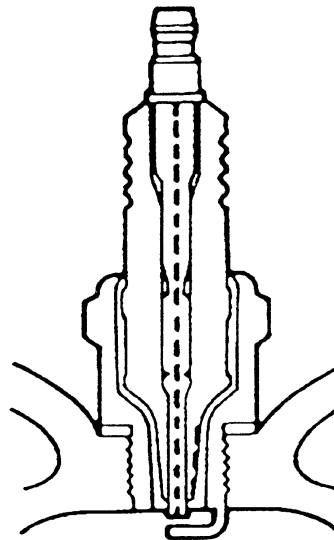

Bridged Electrodes
 Fouling deposits between the electrodes "ground out" the high voltage needed to fire the spark plug. The arc between the electrodes does not occur and the fuel air mixture is not ignited. This causes a power loss and exhausting of raw fuel.

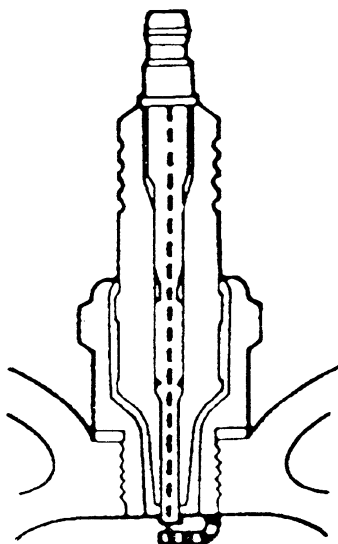

Cracked Insulator
 A crack in the spark plug insulator could cause the high voltage charge to "ground out." Here, the spark does not jump the electrode gap and the fuel air mixture is not ignited. This causes a power loss and raw fuel is exhausted.

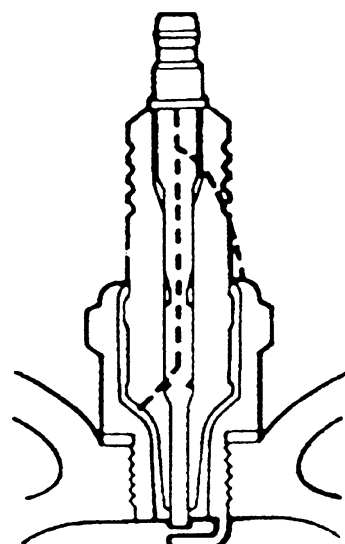

GAP BRIDGED

IDENTIFIED BY DEPOSIT BUILD-UP CLOSING GAP BETWEEN ELECTRODES.

CAUSED BY OIL OR CARBON FOULING. REPLACE PLUG, OR, IF DEPOSITS ARE NOT EXCESSIVE THE PLUG CAN BE CLEANED.

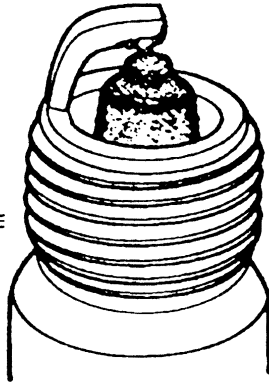

OIL FOULED

IDENTIFIED BY WET BLACK DEPOSITS ON THE INSULATOR SHELL BORE ELECTRODES.

CAUSED BY EXCESSIVE OIL ENTERING COMBUSTION CHAMBER THROUGH WORN RINGS AND PISTONS, EXCESSIVE CLEARANCE BETWEEN VALVE GUIDES AND STEMS, OR WORN OR LOOSE BEARINGS. CORRECT OIL PROBLEM. REPLACE THE PLUG.

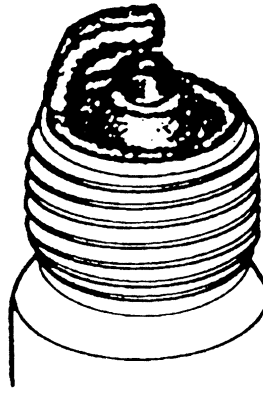

CARBON FOULED

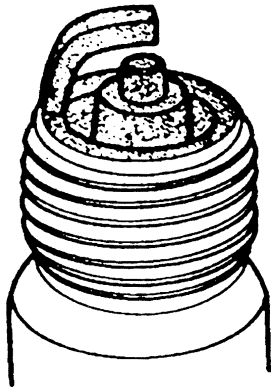

IDENTIFIED BY BLACK, DRY FLUFFY CARBON DEPOSITS ON INSULATOR TIPS, EXPOSED SHELL SURFACES AND ELECTRODES

CAUSED BY TOO COLD A PLUG, WEAK IGNITION, DIRTY AIR CLEANER, DEFECTIVE FUEL PUMP, TOO RICH A FUEL MIXTURE, IMPROPERLY OPERATING HEAT RISER OR EXCESSIVE IDLING. CAN BE CLEANED.

NORMAL

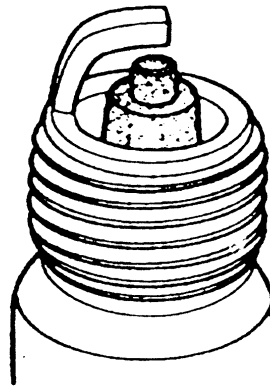

IDENTIFIED BY LIGHT TAN OR GRAY DEPOSITS ON THE FIRING TIP.

PRE-IGNITION

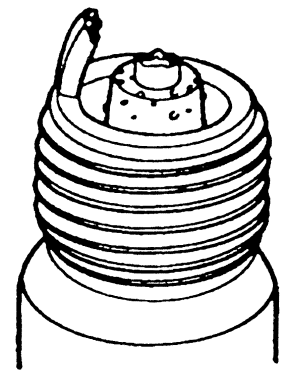

IDENTIFIED BY MELTED ELECTRODES AND POSSIBLY BLISTERED INSULATOR. METALIC DEPOSITS ON INSULATOR INDICATE ENGINE DAMAGE.

CAUSED BY WRONG TYPE OF FUEL, INCORRECT IGNITION TIMING OR ADVANCE, TOO HOT A PLUG, BURNT VALVES OR ENGINE OVERHEATING. REPLACE THE PLUG.

OVERHEATING

IDENTIFIED BY A WHITE OR LIGHT GRAY INSULATOR WITH SMALL BLACK OR GRAY BROWN SPOTS AND WITH BLuish-BURNT APPEARANCE OF ELECTRODES.

CAUSED BY ENGINE OVERHEATING, WRONG TYPE OF FUEL, LOOSE SPARK PLUGS, TOO HOT A PLUG, LOW FUEL PUMP PRESSURE OR INCORRECT IGNITION TIMING. REPLACE THE PLUG.

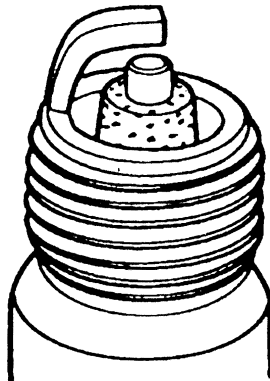

FUSED SPOT DEPOSIT

IDENTIFIED BY MELTED OR SPOTTY DEPOSITS RESEMBLING BUBBLES OR BLISTERS.

CAUSED BY SUDDEN ACCELERATION. CAN BE CLEANED IF NOT EXCESSIVE, OTHERWISE REPLACE PLUG.

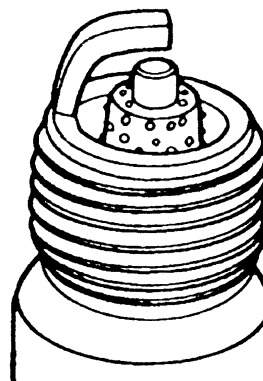

1.80mm-4.34mm
(0.071-0.170 INCH) WITH TAPPET FULLY
COLLAPSED ON BASE CIRCLE AFTER ASSEMBLY

FULCRUM AND BOLT MUST
BE FULLY SEATED AFTER
FINAL TORQUE

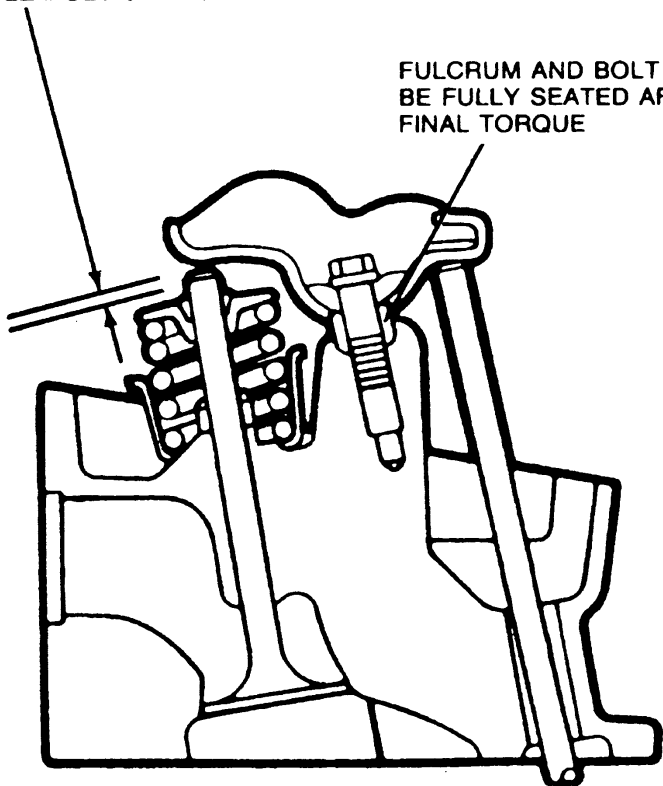

Ø OF KEYWAY
VERTICAL
WITHIN $\pm 5^\circ$

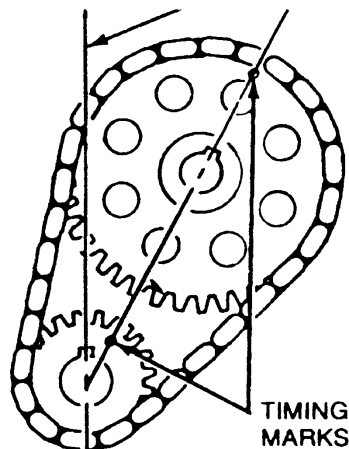

CAMSHAFT
POSITION A

Ø OF KEYWAY
VERTICAL
WITHIN $\pm 5^\circ$

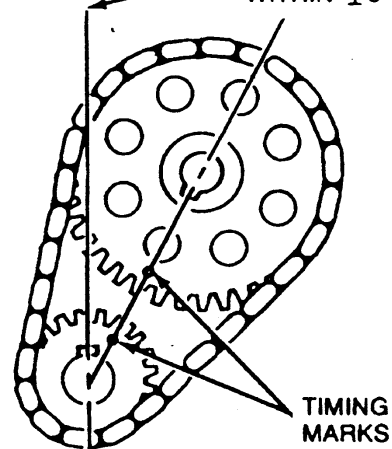

CAMSHAFT
POSITION B

CYL. NO.	CAMSHAFT POSITION	
	A	B
	TIGHTEN FULCRUM BOLTS AS NOTED	
1	INTAKE-EXHAUST	—
2	INTAKE	EXHAUST
3	EXHAUST	INTAKE
4	—	INTAKE-EXHAUST

TIMING POINTER

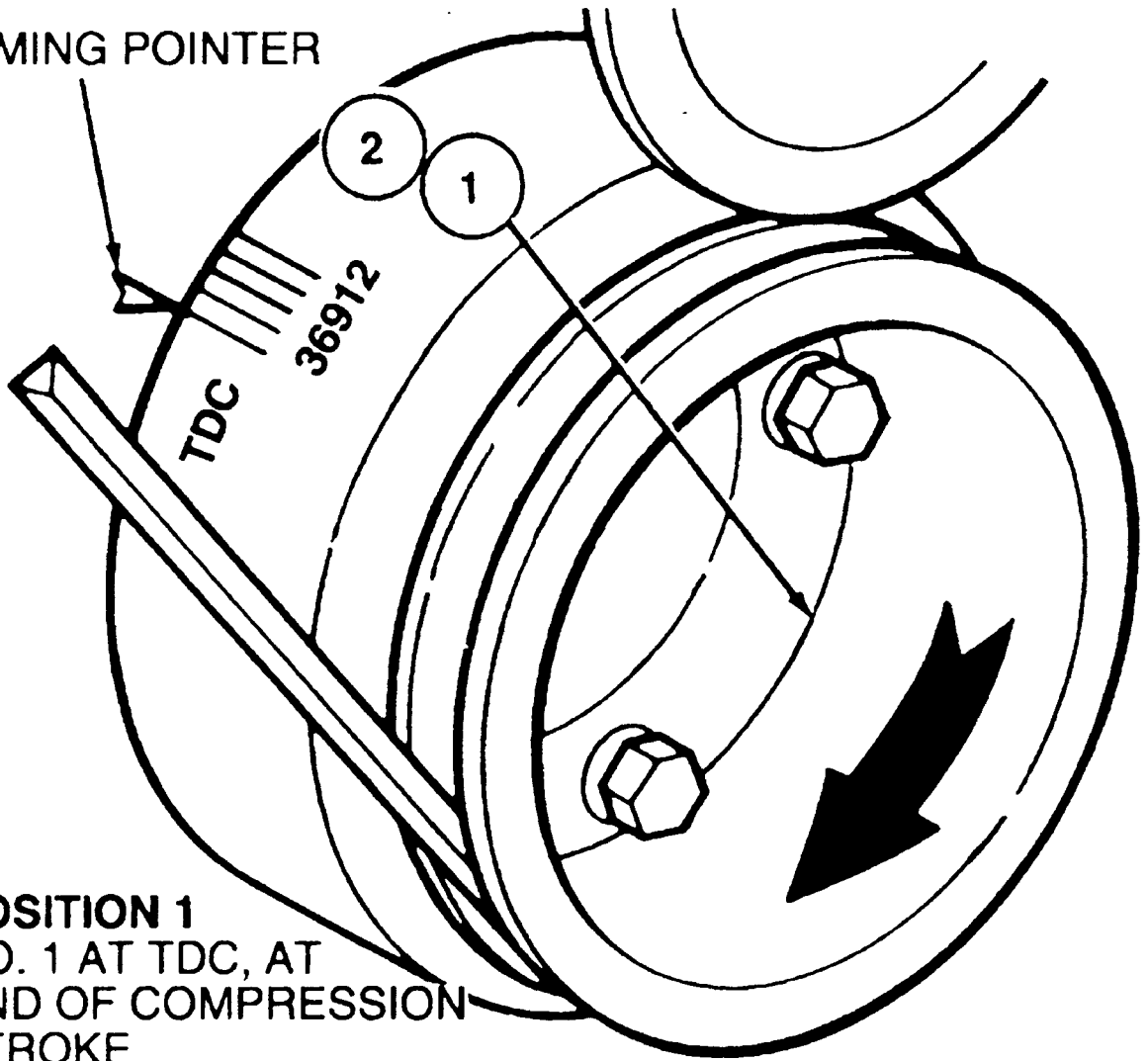

POSITION 1
NO. 1 AT TDC, AT
END OF COMPRESSION
STROKE

POSITION 2
ROTATE CRANKSHAFT
ONE REVOLUTION — 360 DEGREES

TIMING POINTER

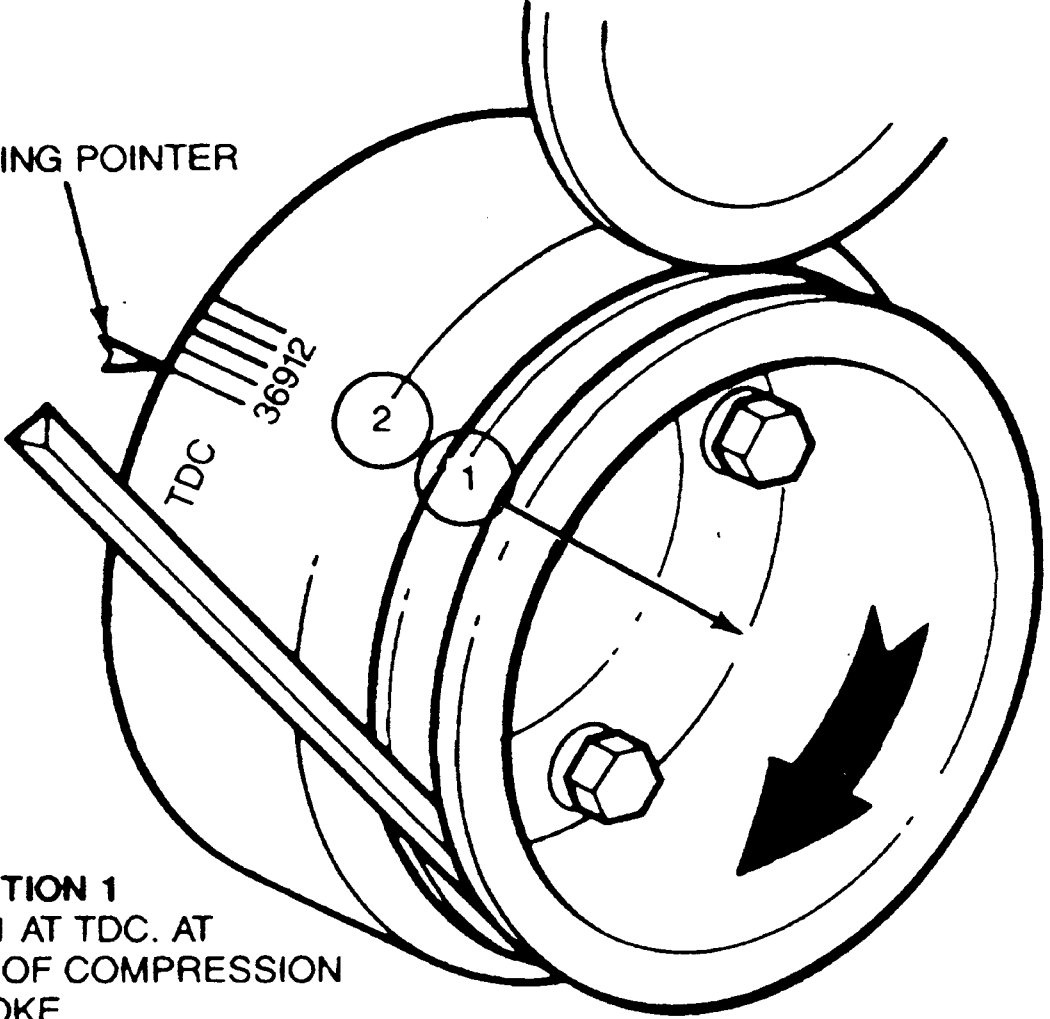

POSITION 1
 NO. 1 AT TDC. AT
 END OF COMPRESSION
 STROKE

POSITION 2
 ROTATE CRANKSHAFT
 ONE REVOLUTION — 360
 DEGREES

CYL. NO.	CRANKSHAFT POSITION	
	1	2
	SET GAP OF VALVES NOTED	
1	INT — EXH	NONE
2	EXH	INT
3	INT	EXH
4	EXH	INT
5	NONE	INT — EXH
6	INT	EXH

TAPPET COMPRESSOR
T89P-6500-A

NOTE POSITION
OF CAM LOBES

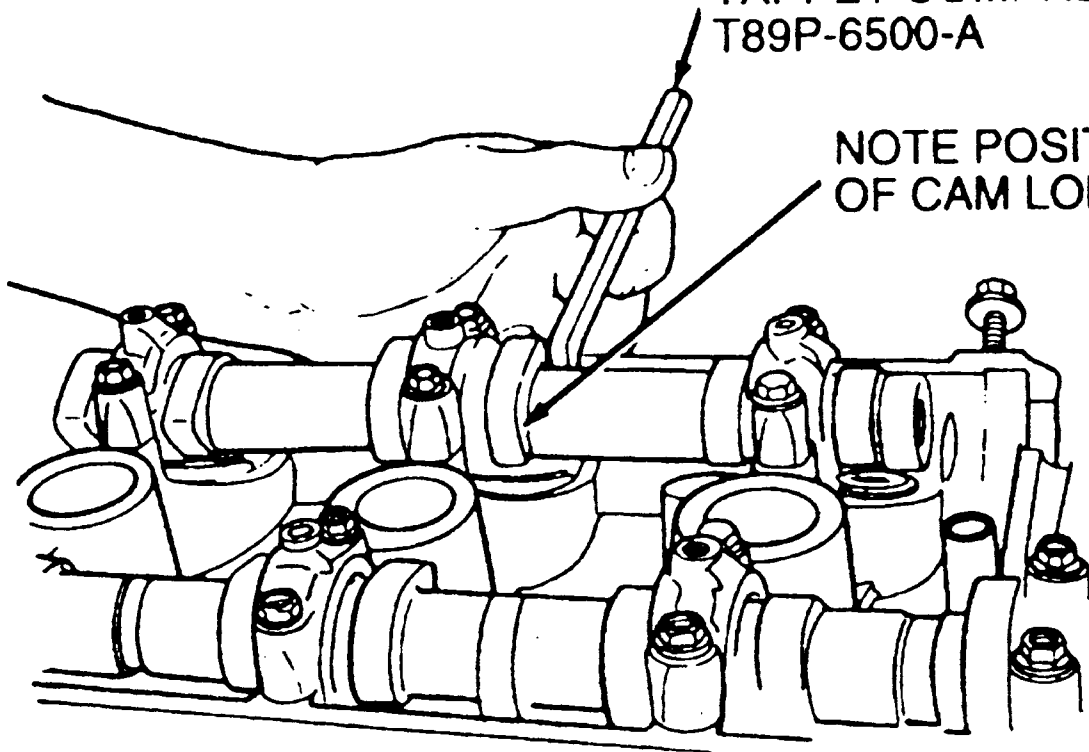

TAPPET HOLDER
T89P-6500-B

CORRECT CAM
LOBE POSITION

TAPPET COMPRESSOR
T89P-6500-A

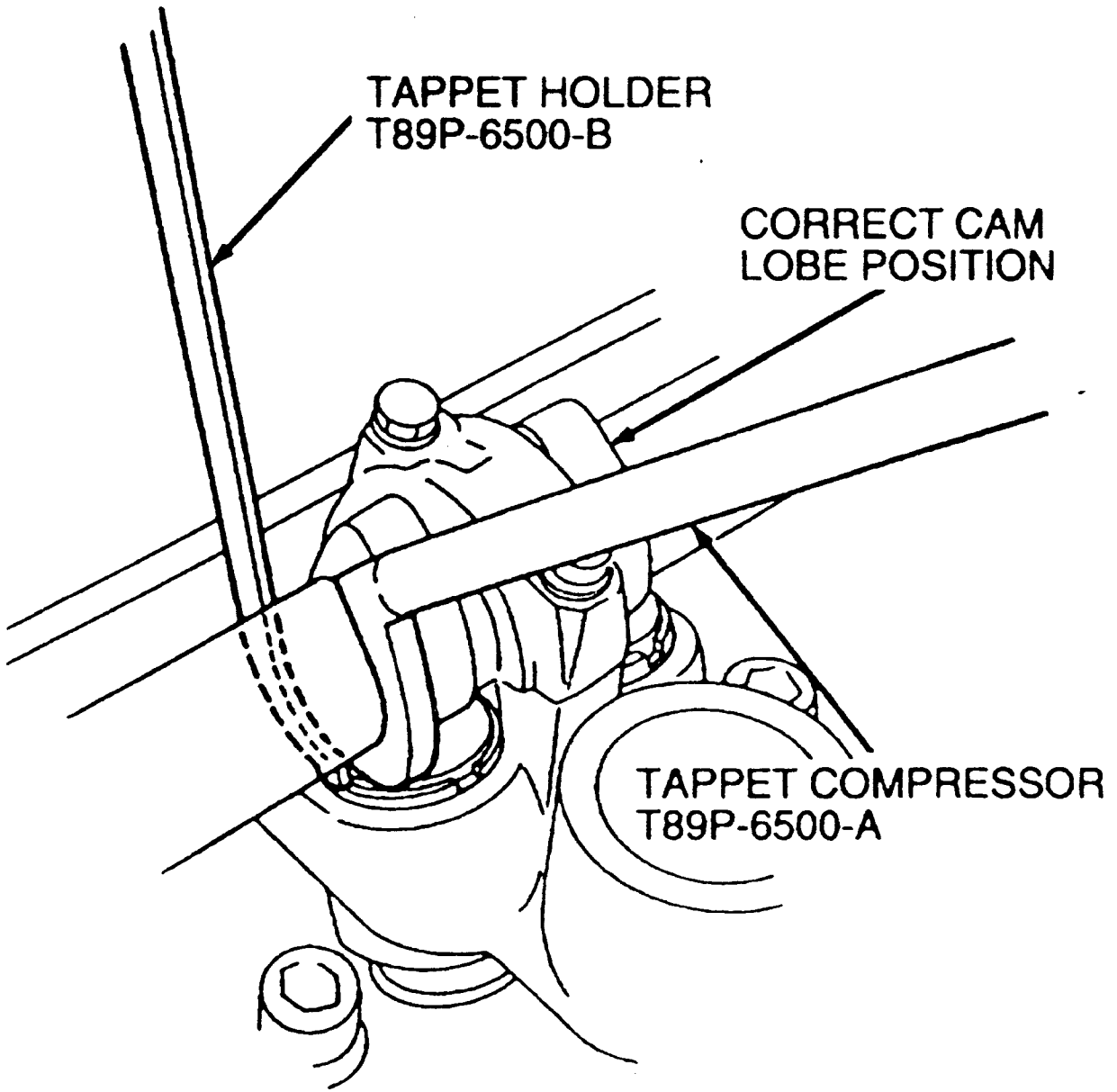

**TAPPET HOLDER
T89P-6500-B**

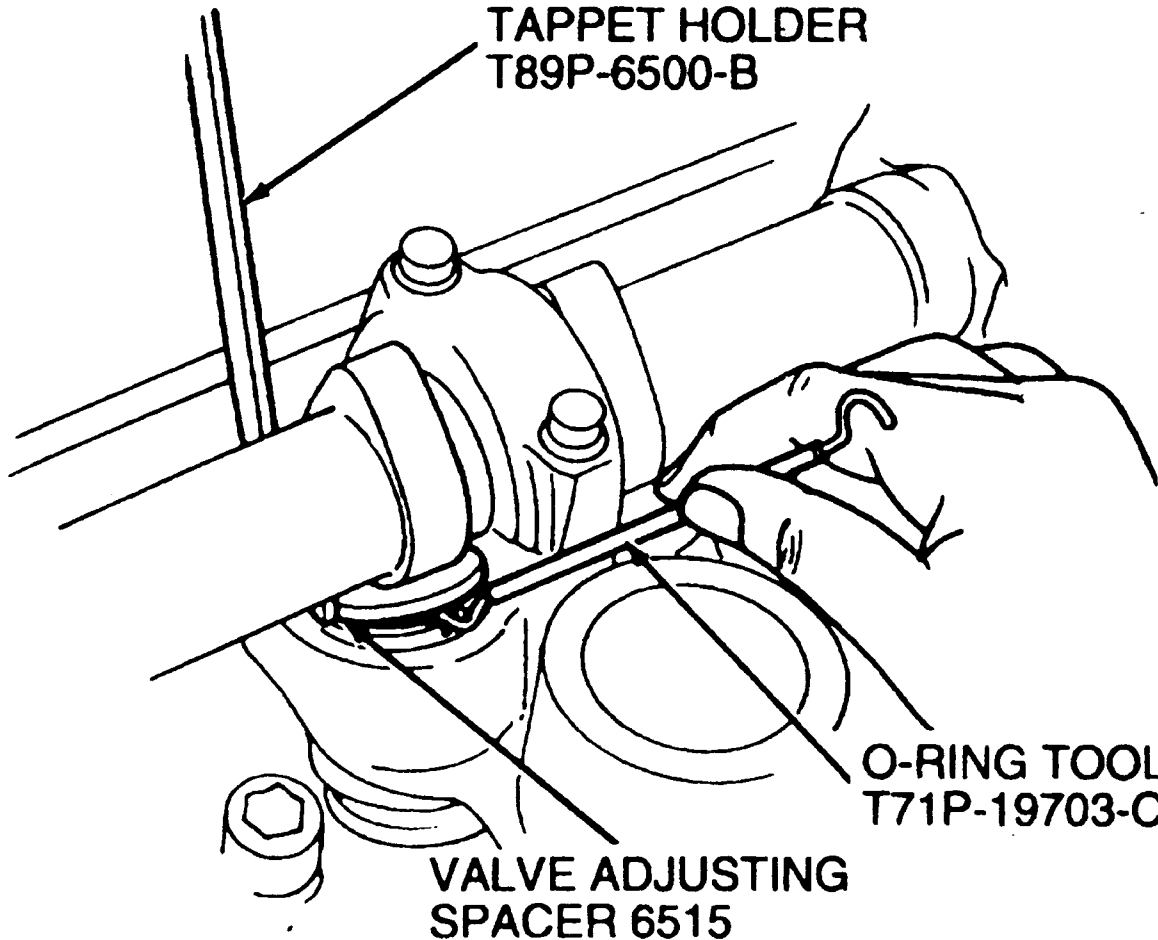

**O-RING TOOL
T71P-19703-C**

**VALVE ADJUSTING
SPACER 6515**